



► **Tandem**  
Door Air Curtains

# Tandem

Door air curtains with patented Tandem technology  
for effective cold air screening

► **Technical catalogue**

**KAMPMANN**



# Contents

<b>01 ▶ Product information</b>	<b>6</b>
▶ Overview	7
▶ Product data	8
▶ Selection guide: Overview of models	9
▶ Tandem at a glance	10
<b>02 ▶ Technical data</b>	<b>12</b>
▶ Information on use	13
▶ Tandem 300	14
▶ Tandem 300 ceiling cassette units	16
▶ Tandem 365	18
<b>03 ▶ Design information</b>	<b>20</b>
▶ Arrangement and adjustment of air outlet	23
▶ Unit selection and combination options	24
▶ Selection process	27
▶ Brackets	28
▶ Fixing points and LPHW connection	30
<b>04 ▶ Controls</b>	<b>34</b>
▶ Control valves	34
▶ Control – Tandem EC, electromechanical model	35
▶ Electrical installation of Tandem EC, electromechanical model	37
▶ Control – Tandem EC, KaControl model	43
▶ Electrical installation of Tandem EC, KaControl model	45
▶ KaControl integration into intelligent building networks (IoT)	46
▶ KaControl	47
<b>05 ▶ Ordering information</b>	<b>48</b>
▶ Tandem 300 door air curtain	48
▶ Tandem 365 door air curtain	49
▶ Accessories	50

Tandem door air curtains:  
Effective cold air screening for a comfortable interior climate.





Adverse weather stays outside all year round, thanks to the enhanced penetration depth between two parallel air streams of different temperature

# 01 ▶ Product information

---



## Tandem–Door air curtains with patented Tandem technology

The screening effect of Tandem door air curtains creates a comfortable indoor climate with open doors.

The perceptible warm air stream creates a rapid feeling of comfort around people.

Unlike conventional door air curtains, a patented dynamic and self-regulating ambient air stream provides for more effective and energy-saving screening of cold air from outdoors.

The cold ambient air stream has a greater penetration depth than the warm air stream and acts as a back-up air stream. The contraction of both air streams causes the ambient air stream to pull the warm air stream downwards with it.

Adverse energy-intensive turbulence occurs primarily between the outside air and the unheated ambient air stream.

The Coanda effect produces even greater penetration depth: the contraction of both air streams causes the ambient air stream to pull the warm air stream downwards with it. Energy-saving benefits are provided by the ambient air stream, and not just as it does not have to be heated as part of the entire air stream. It also provides for even greater screening, thereby enabling it to be installed at even greater heights.

### Effectiveness of Tandem

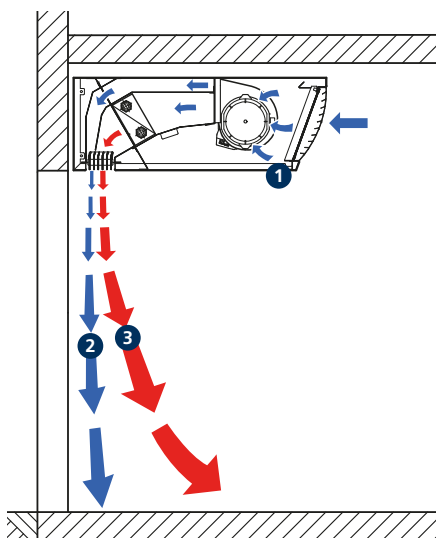

- 1 Tandem door air curtain
- 2 ambient air stream
- 3 warm air stream

### 38 % energy savings

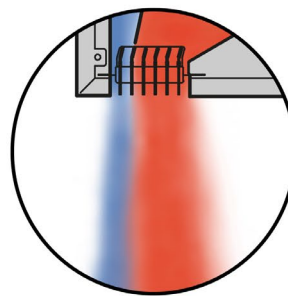

Approx. 38% energy savings over conventional systems can be obtained by a combination of:

- ▶ unheated ambient air stream
- ▶ increased penetration depth due to the Coanda effect
- ▶ comparatively smaller warm air volume.

## Product data



### Product advantages

- ▶ 38% energy savings due to unheated ambient air stream (patented Tandem technology)
- ▶ minimal heating requirement with the same screening effect
- ▶ valves (optional) can be concealed behind the casing
- ▶ energy-efficient EC fans

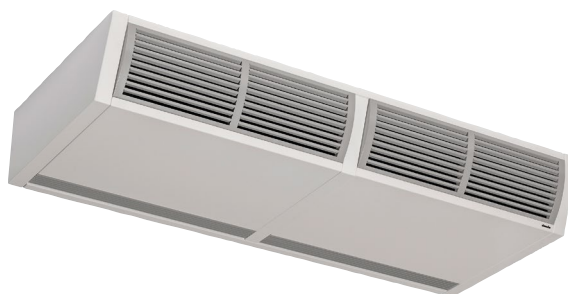

### Features

- ▶ free-hanging unit (extensions possible) or recessed ceiling unit (only with Tandem 300)
- ▶ ambient and warm air stream
- ▶ EC fans

#### Heating Installation

- ▶ PWW
- ▶ wall- or ceiling-mounted
- ▶ flush ceiling installation (only with Tandem 300)
- ▶ optional

#### KaControl

#### Connections

- ▶ heat exchanger connection 3/4"

### Performance data

#### Heat output<sup>1)</sup> [kW]

- ▶ 4.6–41.3

#### Air volume<sup>2)</sup> [m<sup>3</sup>/h]

- ▶ 700–8480

#### Sound pressure level<sup>3)</sup> [dB(A)]

- ▶ 32–67

#### Operating limits

- ▶ max. operating pressure: 10 bar
- ▶ max. entering water temperature: 90 °C
- ▶ min. entering air temperature: 6 °C
- ▶ max. entering air temperature: 40 °C

### Applications

Tandem door air curtains efficiently screen cold outside air at open doorways.



Retail chains



Showrooms and shop floors



Restaurants and cafés



Public buildings

<sup>1)</sup> at LPHW 75/65,  $t_{L1} = 20\text{ °C}$

<sup>2)</sup> total, continuously variable control

<sup>3)</sup> The sound pressure levels were calculated based on an assumed room insulation of 16 dB(A). This corresponds to a distance of 3 m, a room volume of 2000 m<sup>3</sup> and a reverberation time of 1.0 s (in accordance with VDI 2081).



# Selection guide: overview of models

Max. discharge height <sup>1)</sup>	Model	Max. door width	Unit design	Total air volume <sup>2)</sup>	Heat output <sup>3)</sup>	Sound pressure level <sup>4)</sup>	Sound power level	Further information
[m]		[m]		[m³/h]	[kW]	[dB(A)]	[dB(A)]	
2.7–3.2	12	1.25	Tandem 300	700 – 2030	4.6 – 9.6	32 – 61	48 – 77	▶ Pages 14 – 15
			Tandem 300 Ceiling cassette unit					▶ Pages 16 – 17
	20	2.00	Tandem 300	1200 – 3830	8.3 – 18.5	35 – 63	51 – 79	▶ Pages 14 – 15
			Tandem 300 Ceiling cassette unit					▶ Pages 16 – 17
	25	2.50	Tandem 300	1480 – 5410	10.8 – 26.5	37 – 63	53 – 79	▶ Pages 14 – 15
			Tandem 300 Ceiling cassette unit					▶ Pages 16 – 17
30	3.00	Tandem 300	1850 – 5810	13.5 – 30.1	37 – 64	53 – 81	▶ Pages 14 – 15	
		Tandem 300 Ceiling cassette unit					▶ Pages 16 – 17	
3.2–4.0	12	1.25	Tandem 365	1090 – 3090	7.1 – 14.3	33 – 64	49 – 80	▶ Pages 18 – 19
	20	2.00	Tandem 365	1860 – 5830	12.8 – 27.8	37 – 66	53 – 82	▶ Pages 18 – 19
	27	2.75	Tandem 365	2550 – 8480	18.1 – 41.3	38 – 67	54 – 83	▶ Pages 18 – 19

## Installation options

Example shown Tandem 300

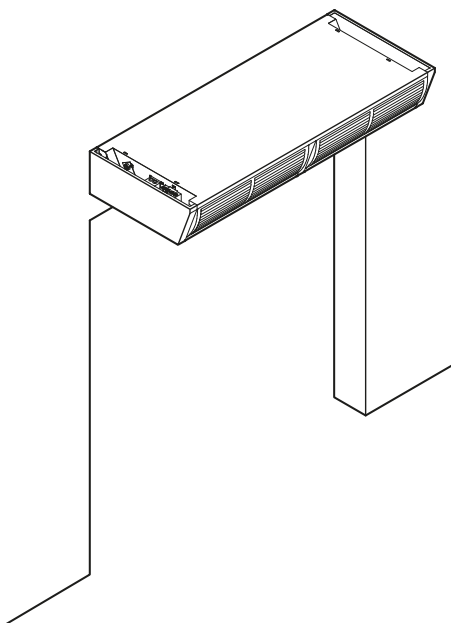

Example shown Tandem 300 recessed ceiling unit

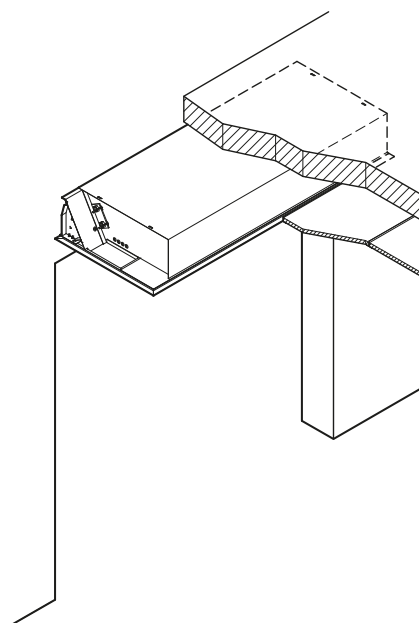

<sup>1)</sup> at low to medium pressure, requirements and conditions, see page 21

<sup>2)</sup> continuously variable control

<sup>3)</sup> at LPHW 75 / 65, t<sub>l1</sub>=20 °C

<sup>4)</sup> The sound pressure levels were calculated based on an assumed room insulation of 16 dB(A). This corresponds to a distance of 3 m, a room volume of 2000 m³ and a reverberation time of 1.0 s (in accordance with VDI 2081).

## Tandem at a glance

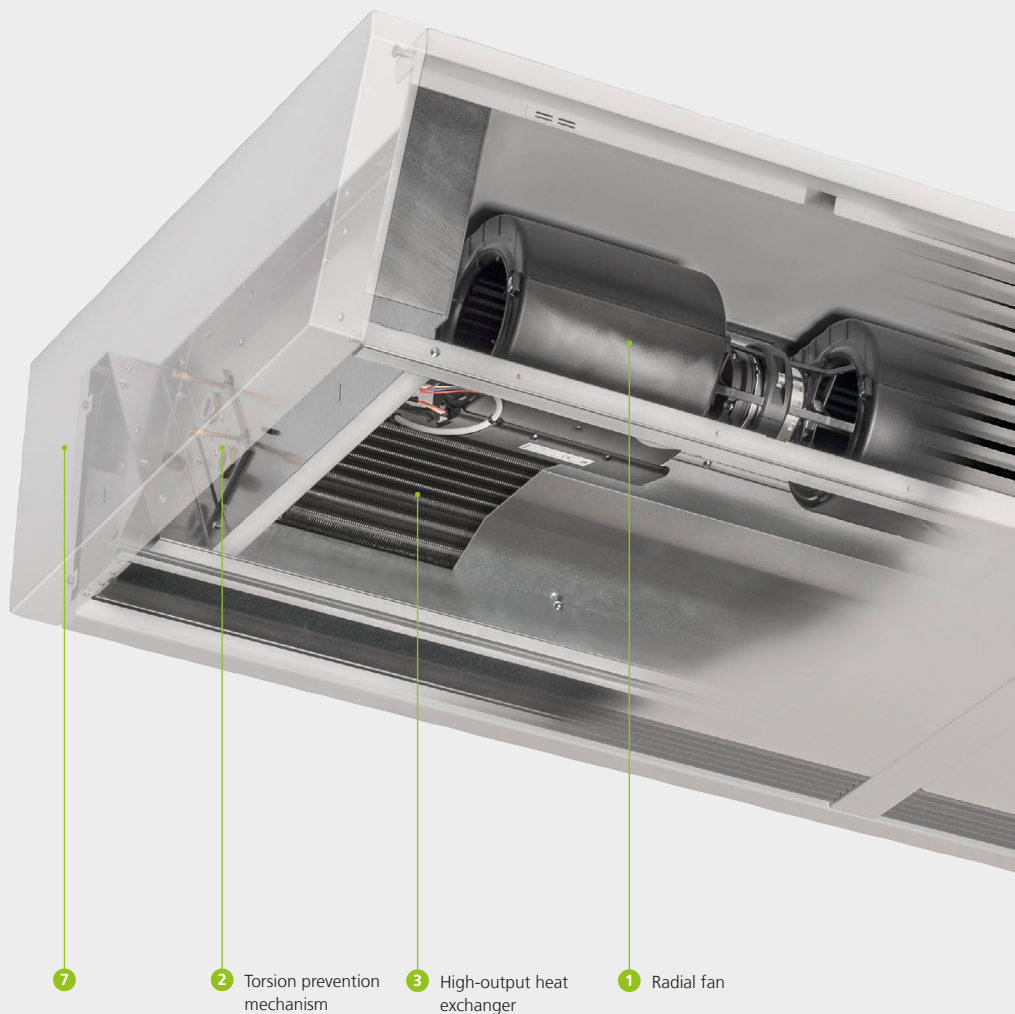

## Features

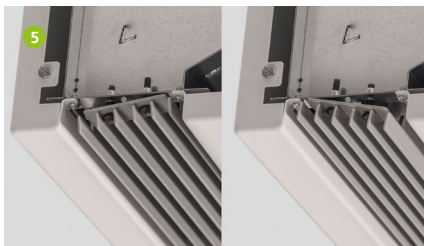
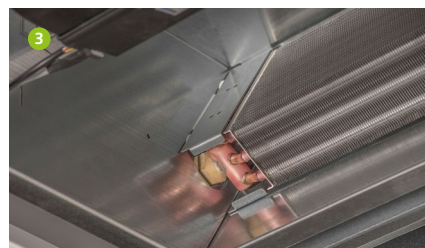
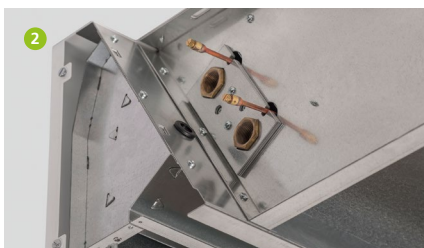

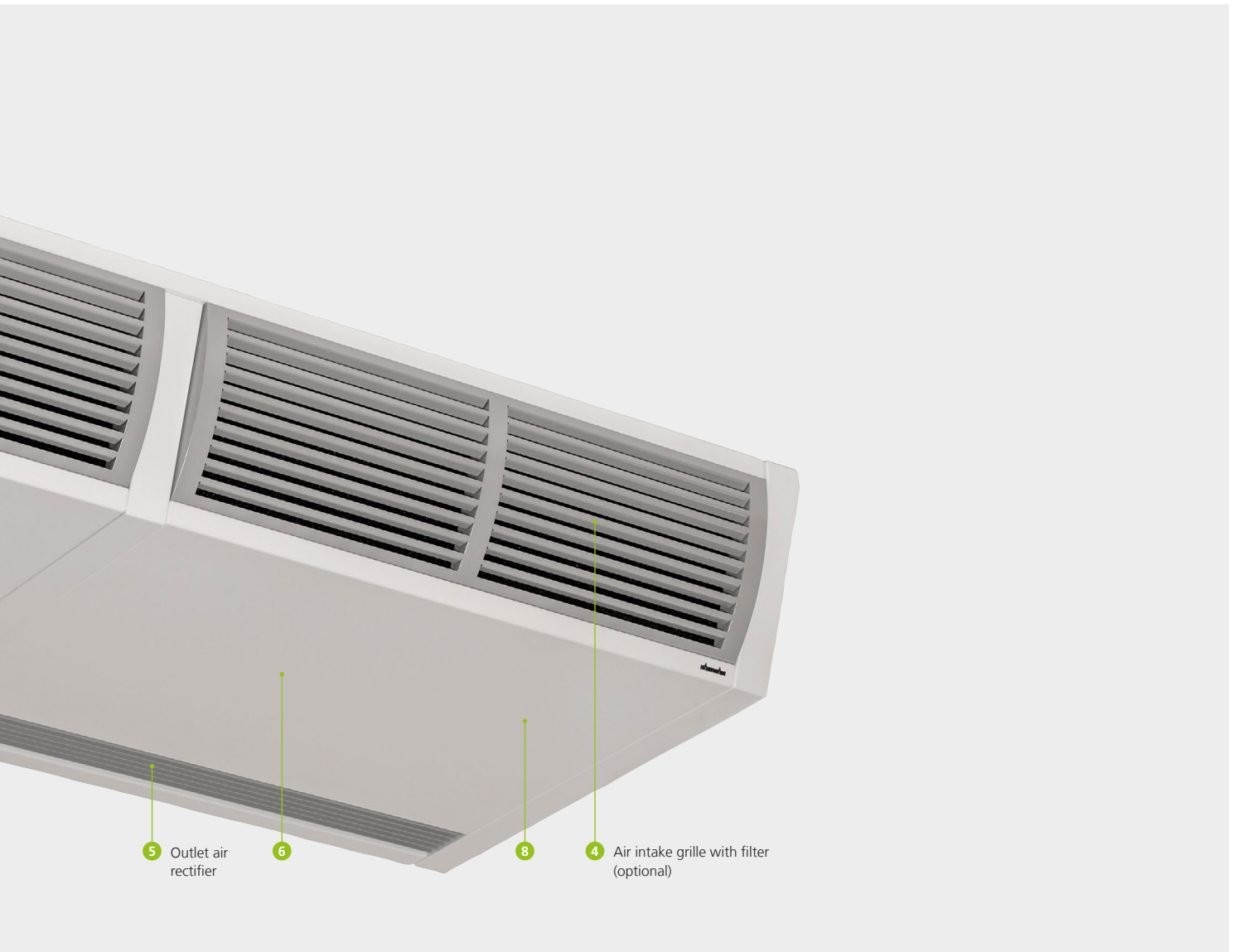
**1 Radial fan:**

- ▶ patented generation of an ambient and warm air stream (Tandem technology) by a single fan group for the effective and energy-saving screening of outside cold air
- ▶ direct-driven radial fan with backward curved impeller, continuously variable EC model

**2 Anti-twist device for heating connection:**

- ▶ prevents damage to the heat exchanger when fitting the valves
- ▶ optional: valves (accessories)

**3 High-output heat exchanger:**

- ▶ proven combination of copper/aluminium

**4 Air intake grille with filter (optional):**

- ▶ opens with minimal effort
- ▶ simple filter replacement without tools

**5 Outlet air rectifier:**

- ▶ consisting of an airflow-optimised, adjustable louvre package
- ▶ outlet air rectifier in the air outlet for minimal turbulence and even air discharge, powder-coated in RAL 9006
- ▶ the discharged flat air stream has less divergence but improved penetration depth, significantly reducing air exchange
- ▶ adjusts up to 20° to adjust the direction of the air outlet

**6 Service hatch:**

- ▶ simple and quick to open
- ▶ quick access for maintenance

**7 Side panel:**

- ▶ opens without the need for tools for fast access to valves (accessories) and electrical connections

**8 Casing:**

- ▶ robust sheet steel construction, with an elegant design
- ▶ side panels, simple to dismantle for maintenance purposes
- ▶ powder-coated in RAL 9016, other non-standard colours available
- ▶ lengths of > 3.0m are possible by coupling the units with a connection set to provide a continuous run
- ▶ rounded air intake grille, powder-coated in RAL 9006, simple to remove for filter maintenance

# 02 ▶ Technical data

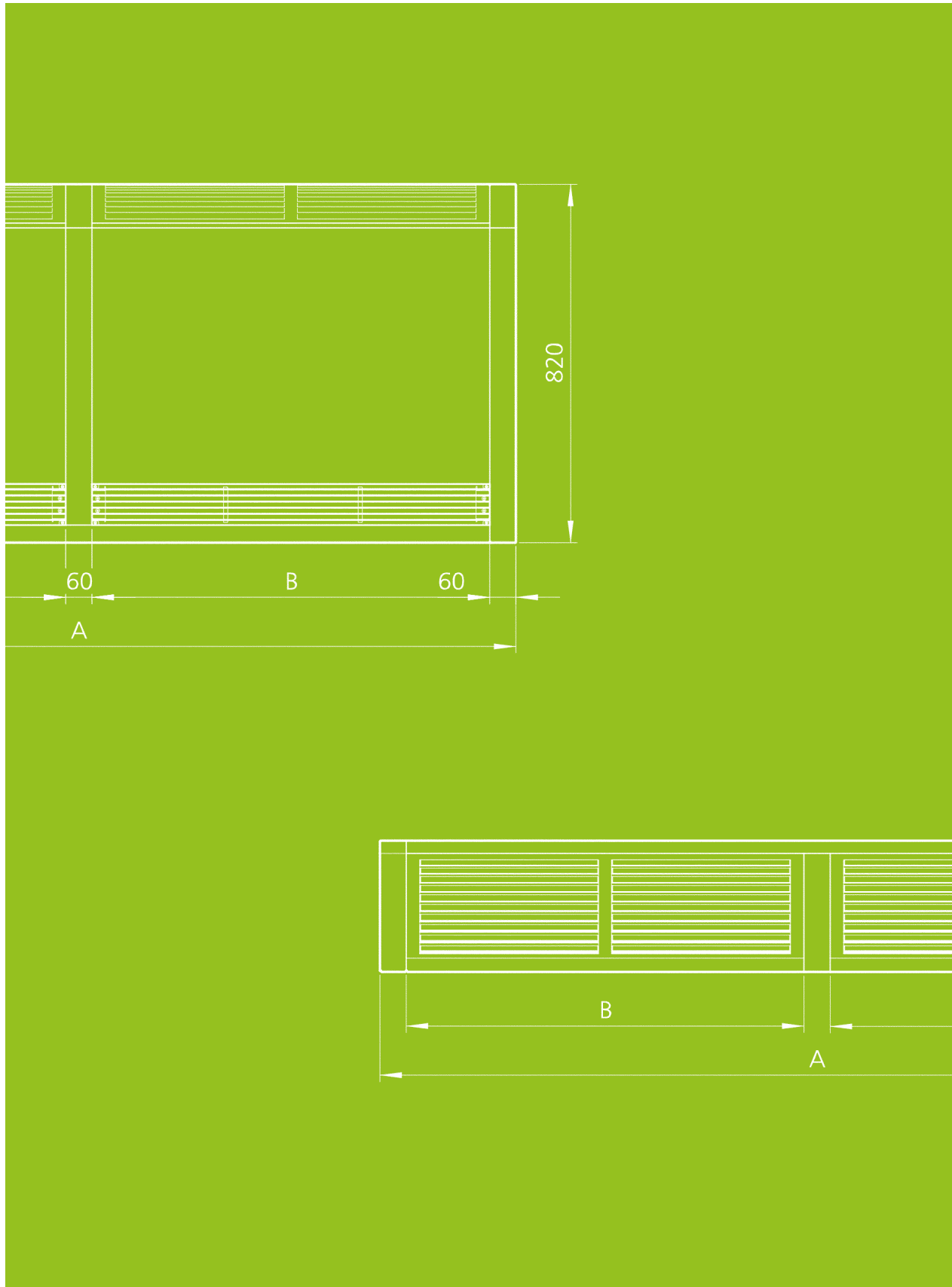

## Information on use

Ideally, door air curtains should have a largely continuous air discharge opening to cover the entire width or height of the doorway.

The outlet temperature should be controllable, depending on the heat or cooling requirement in the room. In heating mode, preferably design the outlet temperature at 32°C, although 36°C is recommended. This requirement applies to the room-side layer with multi-stream systems.

Door air curtains are generally sized in line with VDI 2082 taking into account:

- ▶ door width and door height
- ▶ building position and height
- ▶ wind pressure conditions
- ▶ number and position of entrances
- ▶ type of entrance doors
- ▶ size of sales floor
- ▶ installation height
- ▶ volume of traffic



### European patent

The European Patent Office issued a European patent at the start of 2016 for the air guidance of Tandem door air curtains.

The unique feature of Tandem door air curtains is their air guidance: Tandem door air curtains have a multi-stream air outlet with two air superimposed air streams, generated by a single fan group. A separate unheated ambient air stream automatically adapts to the air volume of the heated air stream when the fan speed changes. The heated air is protected by the ambient air stream and cannot escape to the outside. The ambient air stream has a greater flow velocity than the warm air stream and so acts as a back-up air stream, ensuring the greater stability of the air stream and greater penetration depth.



Tandem in an acoustic measuring chamber

# Tandem 300

## Technical drawings (dimensions in mm)

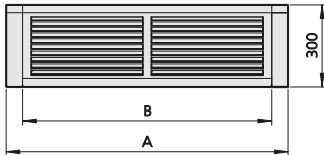

Front view (e.g. Model 12)

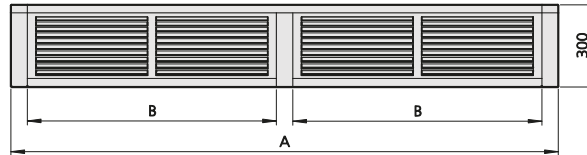

Front view (e.g. Model 20)

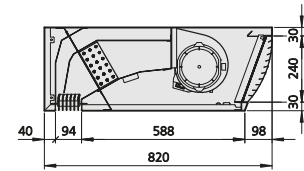

Cross-section

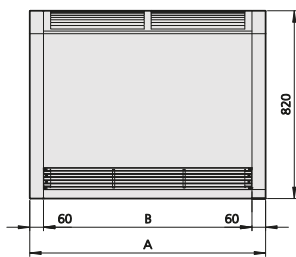

View from below (e.g. Model 12)

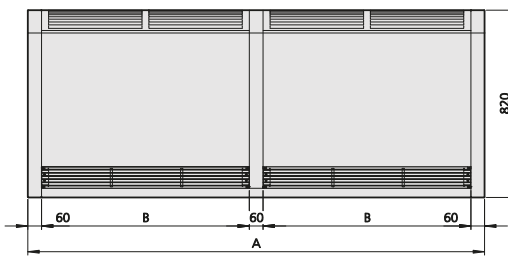

View from below (e.g. Model 20)

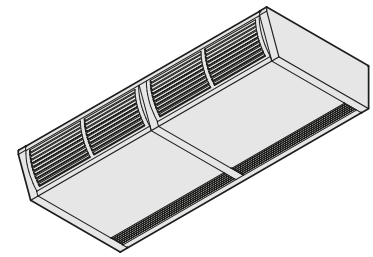

Isometric drawing, view from below (e.g. Model 20)

Model	A	B
[mm]	[mm]	[mm]
12	1250	1130
20	2000	910
25	2500	1160
30	3000	1410

## Specifications

### Weight of basic unit including casing

Model	Weight
	[kg]
12	71
20	112
25	138
30	162

### Water content of heat exchanger

Model	Internal volume
	[l]
12	1.2
20	2.1
25	2.7
30	3.3

## Pressure drop diagram

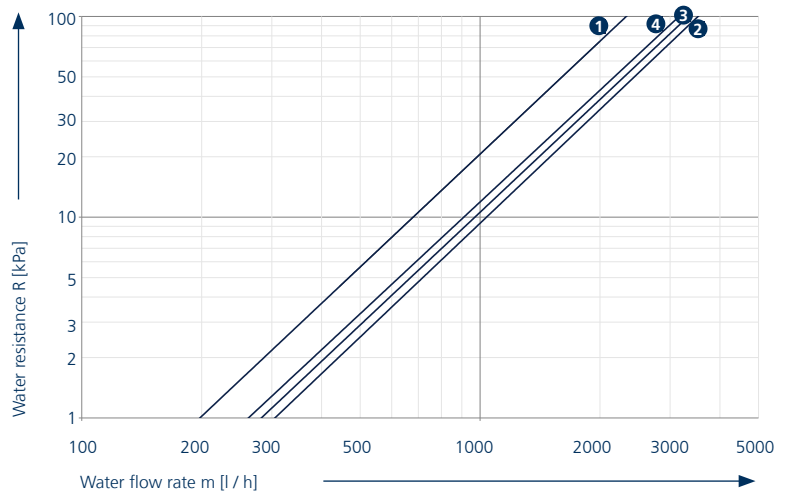

- ① Model 12
- ② Model 20
- ③ Model 25
- ④ Model 30

## Model outputs: LPHW



Model	Max. discharge height <sup>1)</sup> [m]	Max. door width [m]	Control voltage [V]	Air volume			Heat outputs <sup>2)</sup>				Power consumption [W]	Current consumption [A]	Sound pressure level <sup>3)</sup> [dB(A)]	Sound power level [dB(A)]
				Total V [m <sup>3</sup> /h]	Ambient air stream V [m <sup>3</sup> /h]	Warm air stream V [m <sup>3</sup> /h]	at LPHW 75/65°C		at LPHW 82/71°C					
							Q <sub>H</sub> [kW]	t <sub>L2</sub> [°C]	Q <sub>H</sub> [kW]	t <sub>L2</sub> [°C]				
12	2.7 – 3.2	1.25	10	2030	810	1220	9.6	43.1	11.0	46.6	262	1.91	61	77
			8	1900	760	1140	9.2	43.7	10.6	47.3	216	1.56	59	75
			6	1620	650	970	8.3	45.2	9.5	48.9	128	0.88	54	70
			4	1200	480	720	6.8	47.8	7.8	51.9	53	0.38	47	63
			2	700	280	420	4.6	52.2	5.3	57.0	13	0.10	32	48
20	2.7 – 3.2	2.00	10	3830	1530	2300	18.5	43.7	21.3	47.2	485	3.49	63	79
			8	3580	1430	2150	17.7	44.2	20.4	47.8	399	2.86	61	77
			6	2970	1190	1780	15.6	45.8	17.9	49.6	231	1.60	56	72
			4	2140	860	1280	12.4	48.5	14.3	52.8	96	0.70	48	64
			2	1200	480	720	8.3	53.9	9.5	59.0	25	0.20	35	51
25	2.7 – 3.2	2.50	10	5410	2160	3250	26.5	44.0	30.5	47.6	670	4.75	63	79
			8	5050	2020	3030	25.3	44.6	29.1	48.2	548	3.90	62	78
			6	4040	1620	2420	21.8	46.5	25.1	50.5	308	2.16	57	73
			4	2850	1140	1710	17.2	49.6	19.8	54.0	129	0.97	48	64
			2	1480	590	890	10.8	55.7	12.4	61.0	36	0.30	37	53
30	2.7 – 3.2	3.00	10	5810	2320	3490	30.1	45.4	34.6	49.2	741	5.11	65	81
			8	5400	2160	3240	28.7	46.1	33.0	50.0	612	4.20	63	79
			6	4420	1770	2650	25.0	47.7	28.8	51.9	344	2.40	58	74
			4	3270	1310	1960	20.3	50.5	23.3	55.0	149	1.06	51	67
			2	1850	740	1110	13.5	55.8	15.5	61.1	37	0.31	37	53

V [m<sup>3</sup>/h] = air volume, free-blowing; Q<sub>H</sub> [kW] = heat output; t<sub>L1</sub> [°C] = air intake temperature; t<sub>L2</sub> [°C] = air outlet temperature

Make use of our online calculation programs to calculate your heat outputs and flow rates with a couple of clicks!

► [Kampmann.co.uk/tandem](http://Kampmann.co.uk/tandem)

<sup>1)</sup> at low to medium pressure, requirements and conditions, see page 21

<sup>2)</sup> at air intake temperature t<sub>L1</sub> = 20°C

<sup>3)</sup> The sound pressure levels were calculated based on an assumed room insulation of 16 dB(A). This corresponds to a distance of 3 m, a room volume of 2000 m<sup>3</sup> and a reverberation time of 1.0 s (in accordance with VDI 2081).

# Tandem 300 ceiling cassette unit

## Technical drawings (dimensions in mm)

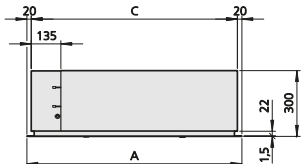

Front view (e.g. Model 12)

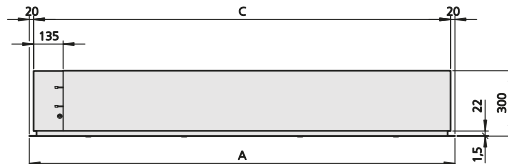

Front view (e.g. Model 20)

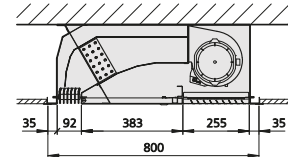

Cross-section

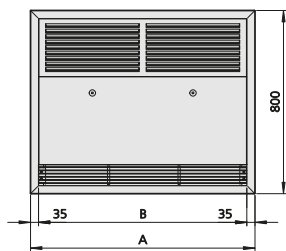

View from below (e.g. Model 12)

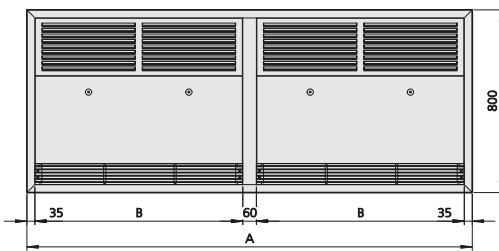

View from below (e.g. Model 20)

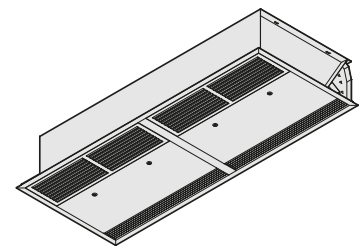

Isometric drawing, view from below (e.g. Model 20)

Model	A	B	C
[mm]	[mm]	[mm]	[mm]
12	1200	1130	1160
20	1950	910	1910
25	2450	1160	2410
30	2950	1410	2910

## Specifications

### Weights of ceiling cassette unit

Model	Weight
	[kg]
12	67
20	106
25	133
30	156

### Water content of heat exchanger

Model	Internal volume
	[l]
12	1.2
20	2.1
25	2.7
30	3.3

## Pressure drop diagram

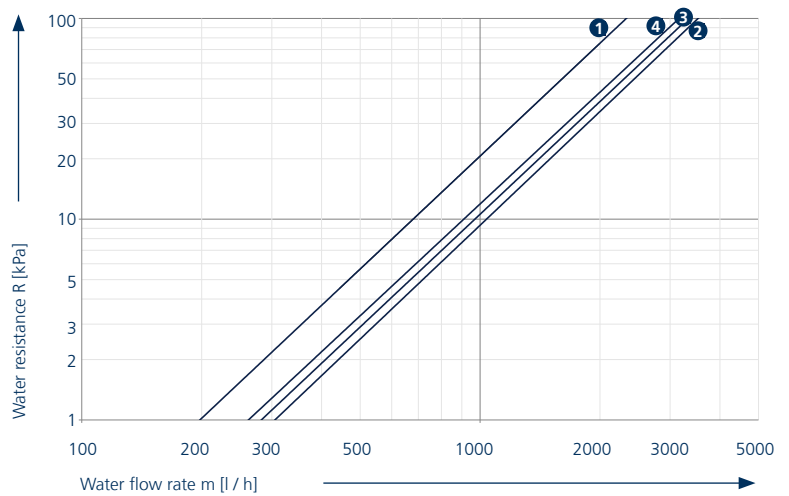

- 1 Model 12
- 2 Model 20
- 3 Model 25
- 4 Model 30



## Model outputs: LPHW



Model	Max. discharge height <sup>1)</sup> [m]	Max. door width [m]	Control voltage [V]	Air volume			Heat outputs <sup>2)</sup>				Power consumption P [W]	Current consumption I [A]	Sound pressure level <sup>3)</sup> L <sub>pA</sub> [dB(A)]	Sound power level L <sub>WA</sub> [dB(A)]
				Total V [m <sup>3</sup> /h]	Ambient air stream V [m <sup>3</sup> /h]	Warm air stream V [m <sup>3</sup> /h]	at LPHW 75/65°C		at LPHW 82/71°C					
							Q <sub>H</sub> [kW]	t <sub>L2</sub> [°C]	Q <sub>H</sub> [kW]	t <sub>L2</sub> [°C]				
12	2.7 – 3.2	1.25	10	2030	810	1220	9.6	43.1	11.0	46.6	262	1.91	61	77
			8	1900	760	1140	9.2	43.7	10.6	47.3	216	1.56	59	75
			6	1620	650	970	8.3	45.2	9.5	48.9	128	0.88	54	70
			4	1200	480	720	6.8	47.8	7.8	51.9	53	0.38	47	63
			2	700	280	420	4.6	52.2	5.3	57.0	13	0.10	32	48
20	2.7 – 3.2	2.00	10	3830	1530	2300	18.5	43.7	21.3	47.2	485	3.49	63	79
			8	3580	1430	2150	17.7	44.2	20.4	47.8	399	2.86	61	77
			6	2970	1190	1780	15.6	45.8	17.9	49.6	231	1.60	56	72
			4	2140	860	1280	12.4	48.5	14.3	52.8	96	0.70	48	64
			2	1200	480	720	8.3	53.9	9.5	59.0	25	0.20	35	51
25	2.7 – 3.2	2.50	10	5410	2160	3250	26.5	44.0	30.5	47.6	670	4.75	63	79
			8	5050	2020	3030	25.3	44.6	29.1	48.2	548	3.90	62	78
			6	4040	1620	2420	21.8	46.5	25.1	50.5	308	2.16	57	73
			4	2850	1140	1710	17.2	49.6	19.8	54.0	129	0.97	48	64
			2	1480	590	890	10.8	55.7	12.4	61.0	36	0.30	37	53
30	2.7 – 3.2	3.00	10	5810	2320	3490	30.1	45.4	34.6	49.2	741	5.11	65	81
			8	5400	2160	3240	28.7	46.1	33.0	50.0	612	4.20	63	79
			6	4420	1770	2650	25.0	47.7	28.8	51.9	344	2.40	58	74
			4	3270	1310	1960	20.3	50.5	23.3	55.0	149	1.06	51	67
			2	1850	740	1110	13.5	55.8	15.5	61.1	37	0.31	37	53

V [m<sup>3</sup>/h] = air volume, free-blowing; Q<sub>H</sub> [kW] = heat output; t<sub>L1</sub> [°C] = air intake temperature; t<sub>L2</sub> [°C] = air outlet temperature

Make use of our online calculation programs to calculate your heat outputs and flow rates with a couple of clicks!

► [Kampmann.co.uk/tandem](http://Kampmann.co.uk/tandem)

<sup>1)</sup> at low to medium pressure, requirements and conditions, see page 21

<sup>2)</sup> at air intake temperature t<sub>L1</sub> = 20°C

<sup>3)</sup> The sound pressure levels were calculated based on an assumed room insulation of 16 dB(A). This corresponds to a distance of 3 m, a room volume of 2000 m<sup>3</sup> and a reverberation time of 1.0 s (in accordance with VDI 2081).

# Tandem 365

## Technical drawings (dimensions in mm)



Front view (e.g. Model 12)

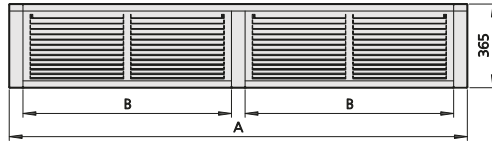

Front view (e.g. Model 20)

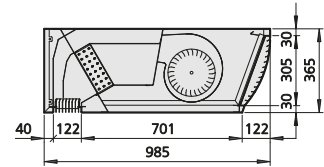

Cross-section

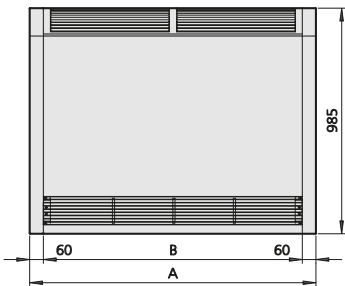

View from below (e.g. Model 12)

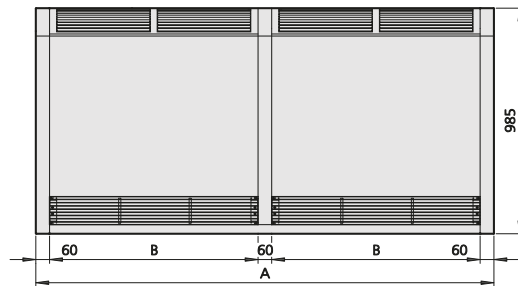

View from below (e.g. Model 20)

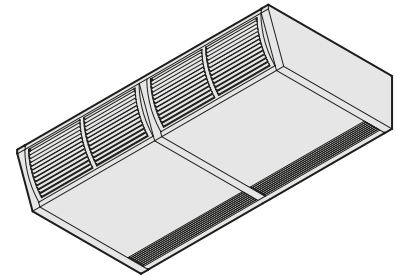

Isometric drawing, view from below (e.g. Model 20)

Model	A	B
[mm]	[mm]	[mm]
12	1250	1130
20	2000	910
27	2750	1285

## Specifications

### Weight of basic unit including casing

Model	Weight
	[kg]
12	94
20	147
27	200

### Water content of heat exchanger

Model	Internal volume
	[l]
12	1.5
20	2.8
27	4.0

## Pressure drop diagram

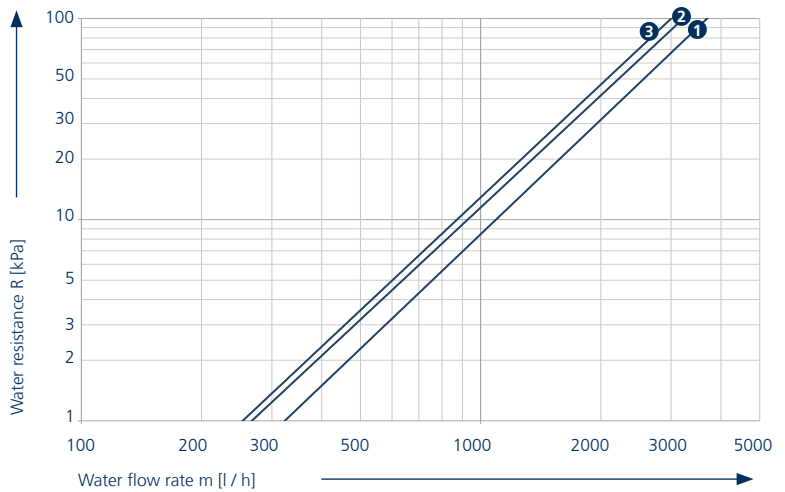

- 1 Model 12
- 2 Model 20
- 3 Model 27

## Model outputs: LPHW



Model	Max. discharge height <sup>1)</sup> [m]	Max. door width [m]	Control voltage [V]	Air volume			Heat outputs <sup>2)</sup>				Power consumption [W]	Current consumption [A]	Sound pressure level <sup>3)</sup> [dB(A)]	Sound power level [dB(A)]
				Total V [m³/h]	Ambient air stream V [m³/h]	Warm air stream V [m³/h]	at LPHW 75/65°C		at LPHW 82/71°C					
							Q <sub>H</sub> [kW]	t <sub>L2</sub> [°C]	Q <sub>H</sub> [kW]	t <sub>L2</sub> [°C]				
12	3.2 – 4.0	1.25	10	3090	1240	1850	14.3	42.7	16,4	46,1	581	2.58	64	80
			8	2610	1040	1570	12.9	44.2	14,8	47,8	337	1.50	60	76
			6	2140	860	1280	11.3	46.0	13,0	49,9	174	0.78	54	70
			4	1630	650	980	9.4	48.2	10,8	52,4	72	0.33	47	63
			2	1090	440	650	7.1	52.1	8,2	56,9	24	0.14	33	49
20	3.2 – 4.0	2.00	10	5830	2330	3500	27.8	43.4	32,0	46,9	1078	4.72	66	82
			8	4930	1970	2960	24.9	44.7	28,6	48,5	621	2.75	62	78
			6	3920	1570	2350	21.4	46.8	24,6	50,8	314	1.41	56	72
			4	2920	1170	1750	17.4	49.2	20,0	53,6	130	0.62	48	64
			2	1860	740	1120	12.8	53.6	14,7	58,7	45	0.28	37	53
27	3.2 – 4.0	2.75	10	8480	3390	5090	41.3	43.9	47,5	47,4	1554	6.75	67	83
			8	7170	2870	4300	37.0	45.3	42,6	49,1	892	3.94	63	79
			6	5610	2240	3370	31.4	47.4	36,1	51,5	445	2.01	57	73
			4	4130	1650	2480	24.4	48.9	28,1	53,3	185	0.89	49	65
			2	2550	1020	1530	18.1	54.8	20,8	60,0	66	0.42	38	54

V [m³/h] = air volume, free-blowing; Q<sub>H</sub> [kW] = heat output; t<sub>L1</sub> [°C] = air intake temperature; t<sub>L2</sub> [°C] = air outlet temperature

Make use of our online calculation programs to calculate your heat outputs and flow rates with a couple of clicks!

► [kammann.co.uk/tandem](https://kammann.co.uk/tandem)

<sup>1)</sup> at low to medium pressure, requirements and conditions, see page 21

<sup>2)</sup> at air intake temperature t<sub>L1</sub> = 20°C

<sup>3)</sup> The sound pressure levels were calculated based on an assumed room insulation of 16 dB(A). This corresponds to a distance of 3 m, a room volume of 2000 m³ and a reverberation time of 1.0 s (in accordance with VDI 2081).

# 03 ▶ Design information

---

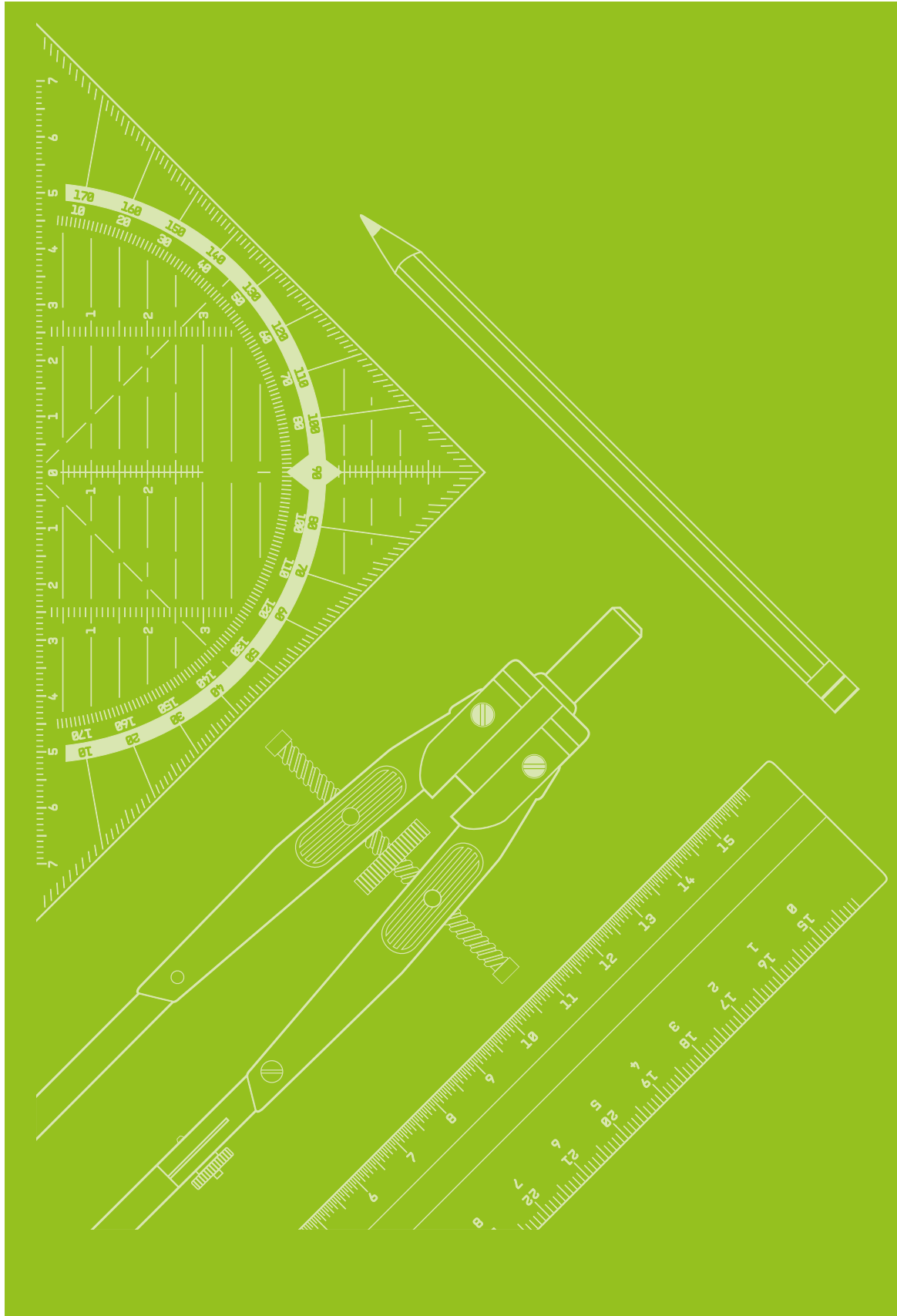

### Operating limits

Extremely poor operating conditions, such as

- ▶ strong negative pressure in the rooms, e.g. produced by mechanical ventilation without the supply of outside air,
- ▶ extremely adverse weathering conditions with high wind speeds in an unprotected position,
- ▶ several open openings to the outside, especially if they are positioned opposite each other,

can impair the effective screening effect of the door air curtains. Additional measures, may need to be put in place, to compensate for the pressure in the room. When designing thoroughfares, note that it may be necessary to close the doors during business hours as well.

Provide for units with higher air outputs and heat outputs should doors need to remain open in large department stores, even in the event of unfavourable or extreme weather.

They have to be in a position to heat up the large volumes of cold air, which can penetrate under certain circumstances.

### Filter

Tandem door air curtains are supplied ex-works without the filter fitted. Note when using filter type 2510031\*\*925 or 2520032\*\*825 (filter class: ISO Coarse) that it can reduce the air volume by about 3% (even with a clean filter).

### Low temperature operation

Modern low temperature and condensing boilers only achieve the highest levels of efficiency with low flow temperatures. Kampmann Tandem door air curtains have high-output copper / aluminium heat exchangers and are suitable for low temperature operation at a flow temperature of approx. 50°C. Thanks to their extremely low water content and fan operation with high air volumes, they react extremely quickly after long cooling down periods.

### Sound pressure level

The aerodynamic construction of Tandem door air curtains only produces a very low noise level, in spite of the high outlet air speeds. Nevertheless, it is important to note that the sound levels may be troubling at high control voltages.

Sound pressure levels are listed in the technical data tables.

The sound pressure levels were calculated with an assumed room insulation of 16 dB(A). This corresponds to a distance of 3 m, a room volume of 2000 m<sup>3</sup> and a reverberation time of 1.0 s (in accordance with VDI 2081). As the actual sound pressure level is seriously dependent on the acoustic properties of the space, the stated figures can deviate in practice. Increased sound levels of approx. 3 – 6 dB (A) can occur under acoustically unfavourable conditions, such as "acoustically hard" ceilings, closed doors and poor absorption surfaces. If two models of the same door air curtain are arranged adjacent to each other, the increased sound pressure level will be approx. 2 – 3 dB (A).

**Max. electrical rating Tandem**

Unit design	Model	Voltage [V] / Frequency [Hz]	Power consumption [kW]	Current consumption [A]	Speed [rpm]
<b>Tandem 300 and Tandem 300 Ceiling cassette unit</b>	Model 12	230 / 50/60	0.25	1.8	1400
	Model 20	230 / 50/60	0.5	3.6	1400
	Model 25	230 / 50/60	0.75	5.4	1400
	Model 30	230 / 50/60	0.75	5.4	1400
<b>Tandem 365</b>	Model 12	230 / 50/60	0.4	2.5	1565
	Model 20	230 / 50/60	0.8	5.0	1565
	Model 27	230 / 50/60	1.2	7.5	1565

The power and current consumption of the control and actuators (optional) is not taken into account.

# Tandem door air curtains

## Arrangement and adjustment of air outlet

When positioned over the door, the equipment needs to be installed in such a way that the air outlet rectifier is positioned as closely as possible to the door opening, preferably directly adjacent to the door.

With horizontal and vertical gaps of more than 500 mm between the door opening and outlet grille, select the next model length up or provide for side panelling similar to a corridor.

The air outlet rectifier has an adjustment range of 20° to tailor the air outlet to individual requirements. The air stream can be specifically and operationally reliably directed outwards or inwards. The air outlet rectifier is factory-set for vertical air outlet.

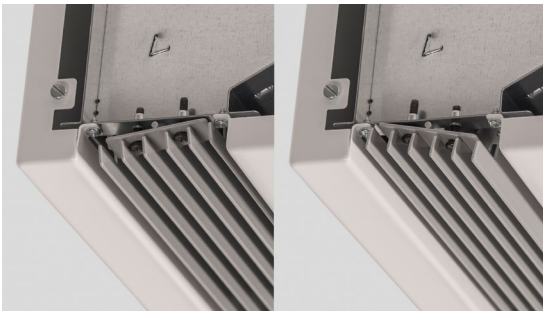

Air outlet adjustment inwards or outwards

## Unit selection and combination options

### Selection of the unit configuration based on maximum discharge height

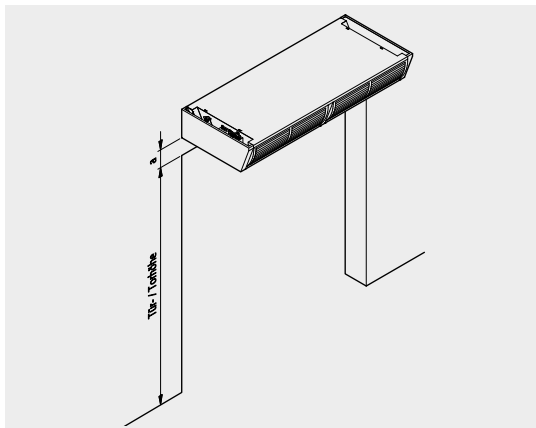

1. Based on discharge height:
  - ▶ max. discharge height  $H_{max}$  = doorway height + a

Also consider:

- ▶ wind pressure conditions
- ▶ impact of thoroughfare, porch, position of the building
- ▶ space occupied by people
- ▶ pressure conditions caused by mechanical ventilation etc.

Max. discharge height $h_{max}$ <sup>1)</sup> [m]	Door air curtain
2.7 – 3.2	Tandem 300
2.7 – 3.2	Tandem 300 ceiling cassette unit
3.2 – 4.0	Tandem 365

### Selection of the unit configuration based on door / doorway width

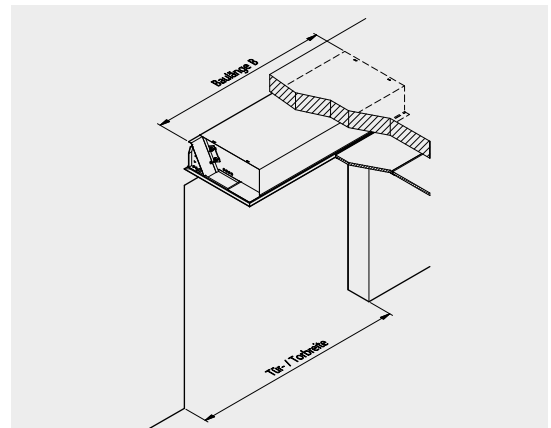

2. Based on door / doorway width:
 

The required model of door air curtain is selected on the basis of the door width:

- ▶ door / doorway width = unit length B

The unit lengths are based on common door opening dimensions.

Other unit lengths can be obtained by combining units of the same or different model, possibly using the connecting set available.

Door / doorway width [m]	Models of door air curtain		
	Tandem 300	Tandem 300 ceiling cassette unit	Tandem 365
< 1.25	Model 12	Model 12	Model 12
2.0	Model 20	Model 20	Model 20
2.5	Model 25	Model 25	Model 27
3.0	Model 30	Model 30	–

<sup>1)</sup> at low to medium pressure, requirements and conditions, see page 21



### Modular design with combined units

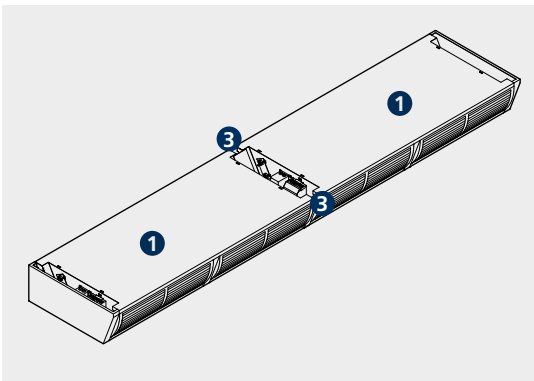

Isometric drawing, view from above

- 1 Tandem door air curtain (e.g. Model 20)
- 2 Connecting panel
- 3 Spacer

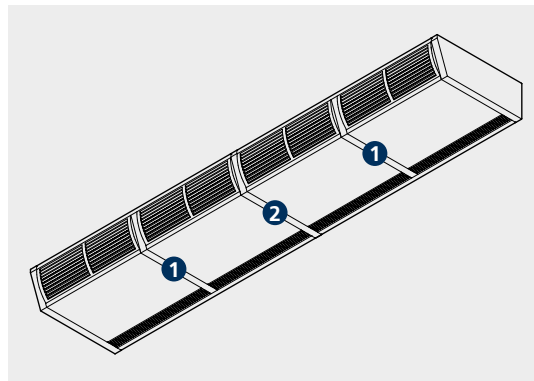

Isometric drawing, view from below

Lengths of > 3 m can be achieved, thanks to the modular construction and can be seamlessly extended (see table below).

Door/ doorway width	Combination options with casing extensions <sup>1)</sup>	
	Tandem 300	Tandem 365
[m]		
3.0	1 × Model 30	Model 20 + Model 12
3.2	Model 20 + Model 12	Model 20 + Model 12
4.0	2 × Model 20	2 × Model 20
4.5	Model 20 + Model 25	2 × Model 12 + Model 20

<sup>1)</sup> up to doorways of 4.5 m in width; other widths are possible using other combinations

# To assist with selection

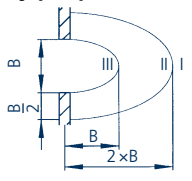
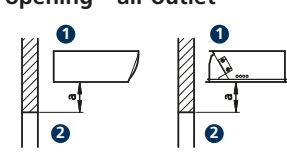
Assessment criteria	Pressure / Requirements / Conditions	Points*														
<b>1. Wind pressure conditions</b>	<table border="1"> <tr> <td>0</td><td>1</td><td>2</td><td>3</td><td>4</td><td>5</td><td>6</td> </tr> <tr> <td colspan="3">weak air flow, densely populated position</td> <td colspan="2">medium air flow</td> <td colspan="2">strong air flow, close to the sea, on a slope</td> </tr> </table>	0	1	2	3	4	5	6	weak air flow, densely populated position			medium air flow		strong air flow, close to the sea, on a slope		<input type="text"/>
0	1	2	3	4	5	6										
weak air flow, densely populated position			medium air flow		strong air flow, close to the sea, on a slope											
<b>2. Passage / Porch</b>	<table border="1"> <tr> <td>0</td><td>1</td><td>2</td><td>3</td><td>4</td> </tr> <tr> <td>available, closed</td><td colspan="2">open</td><td colspan="2">not available</td> </tr> </table>	0	1	2	3	4	available, closed	open		not available		<input type="text"/>				
0	1	2	3	4												
available, closed	open		not available													
<b>3. Position of building</b>	<table border="1"> <tr> <td>0</td><td>1</td><td>2</td><td>3</td><td>4</td><td>5</td><td>6</td> </tr> <tr> <td colspan="3">normal, protected</td> <td colspan="2">open buildings</td> <td colspan="2">free-standing, unprotected</td> </tr> </table>	0	1	2	3	4	5	6	normal, protected			open buildings		free-standing, unprotected		<input type="text"/>
0	1	2	3	4	5	6										
normal, protected			open buildings		free-standing, unprotected											
<b>4. Area constantly occupied by people</b>	<table border="1"> <tr> <td>0</td><td>1</td><td>2</td> </tr> <tr> <td>zone I</td><td>zone II</td><td>zone III</td> </tr> </table>  <p>B = door width</p>	0	1	2	zone I	zone II	zone III	<input type="text"/>								
0	1	2														
zone I	zone II	zone III														
<b>5. Pressure conditions caused by mechanical ventilation</b>	<table border="1"> <tr> <td>0</td><td>1</td><td>2</td><td>3</td><td>4</td> </tr> <tr> <td>overpressure</td><td colspan="2">pressure equalisation</td><td colspan="2">slight negative pressure</td> </tr> </table>	0	1	2	3	4	overpressure	pressure equalisation		slight negative pressure		<input type="text"/>				
0	1	2	3	4												
overpressure	pressure equalisation		slight negative pressure													
<b>6. Other thoroughfares / doors</b>	<table border="1"> <tr> <td>0</td><td>1</td><td>2</td><td>3</td><td>4</td> </tr> <tr> <td>none</td><td colspan="2">at the side of the door opening</td><td colspan="2">opposite the door opening</td> </tr> </table>	0	1	2	3	4	none	at the side of the door opening		opposite the door opening		<input type="text"/>				
0	1	2	3	4												
none	at the side of the door opening		opposite the door opening													
<b>7. Ceiling height</b>	<table border="1"> <tr> <td>0</td><td>1</td><td>2</td><td>3</td><td>4</td> </tr> <tr> <td>up to 2.5 m</td><td colspan="2">up to 3.5 m</td><td colspan="2">more than 4.5 m and/or with staircase</td> </tr> </table>	0	1	2	3	4	up to 2.5 m	up to 3.5 m		more than 4.5 m and/or with staircase		<input type="text"/>				
0	1	2	3	4												
up to 2.5 m	up to 3.5 m		more than 4.5 m and/or with staircase													
<b>8. Floor area</b>	<table border="1"> <tr> <td>0</td><td>1</td><td>2</td><td>3</td><td>4</td> </tr> <tr> <td>up to 100m<sup>2</sup></td><td colspan="2">400m<sup>2</sup></td><td colspan="2">from 800m<sup>2</sup></td> </tr> </table>	0	1	2	3	4	up to 100m <sup>2</sup>	400m <sup>2</sup>		from 800m <sup>2</sup>		<input type="text"/>				
0	1	2	3	4												
up to 100m <sup>2</sup>	400m <sup>2</sup>		from 800m <sup>2</sup>													
<b>9. Gap between door opening – air outlet</b>	<table border="1"> <tr> <td>0</td><td>1</td><td>2</td><td>3</td><td>4</td><td>5</td><td>6</td> </tr> <tr> <td>a=0</td><td colspan="3">a=300 mm</td><td colspan="3">a=600 mm</td> </tr> </table>  <p>1 = Door air curtain, 2 = door a = distance</p>	0	1	2	3	4	5	6	a=0	a=300 mm			a=600 mm			<input type="text"/>
0	1	2	3	4	5	6										
a=0	a=300 mm			a=600 mm												

Points total

\* Please enter points.

# Selection process

## Selection process

Enter points on each scale in line with the conditions on site for the various factors / assessment criteria.

- ▶ Intermediate values are also possible.
- ▶ In extreme cases, factors outside of the point scale can also be taken into consideration. The total of points in the right column of the table gives the total points for determining the maximum discharge heights and discharge widths depending on the switching stage in diagram 1.

- ▶ Note the limits of use (see page 21) when the door air curtains are continuously open

$H_{\max}$  here represents the maximum discharge height for both horizontal and vertical Tandem door air curtains.

## Selection example

Specification: Door air curtain for showroom,  
door: height 2.40m, width 2.00 m

- ▶ weak to moderate air flow (2 points)
- ▶ no porch or passage installed (4 points)
- ▶ normal, protected location (0 points)
- ▶ no people standing/working directly adjacent to the doorway (0 points)
- ▶ balanced pressure conditions (2 points)
- ▶ no other thoroughfares (0 points)
- ▶ room height 3.30 m (2 points)
- ▶ room area 200m<sup>2</sup> (1 point)
- ▶ distance from door opening - air outlet 200mm (2 points)

## Selection

- ▶ door air curtain size 20, thus unit length = door width
- ▶ assessment as per table: total points = 13
- ▶ discharge height = door height + a = 2.4 m + 0.2 m = 2.6 m
- ▶ from diagram 1:  
at least 13 points, as a minimum:  
Tandem 300 door air curtain with  $H_{\max} = 2.70$  m with 8 V actuation

**Result:** Tandem 300 door air curtain, size 20

**Total points:** 13 points

Diagram 1

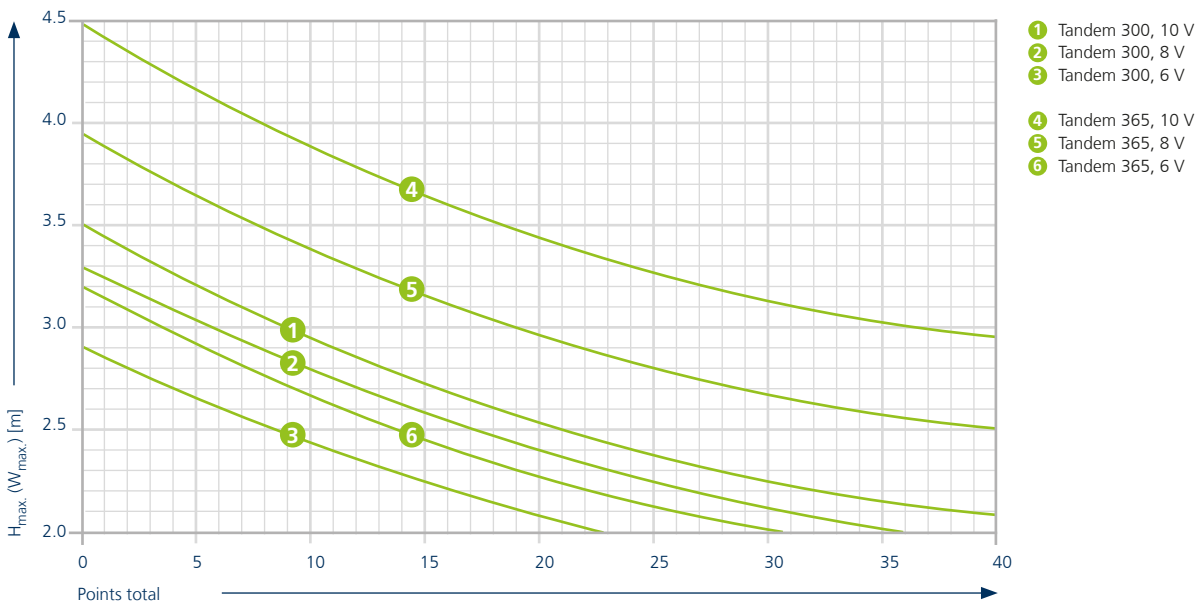

# Brackets

## Overview of types

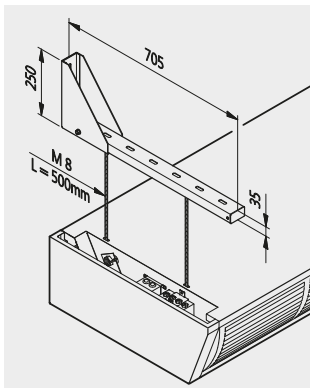

Wall bracket, example shown Tandem 300

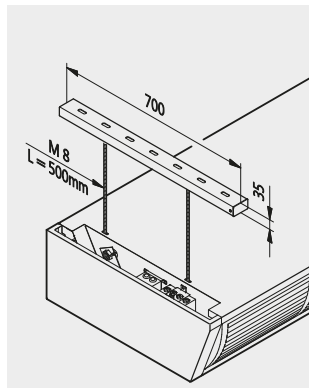

Ceiling bracket, example shown Tandem 300

- ▶ Adjustable towards the door
- ▶ Brackets powder coated traffic white RAL 9016
- ▶ Precise height adjustment is possible with the use of threaded rods

## Slot-in design for wall and ceiling brackets

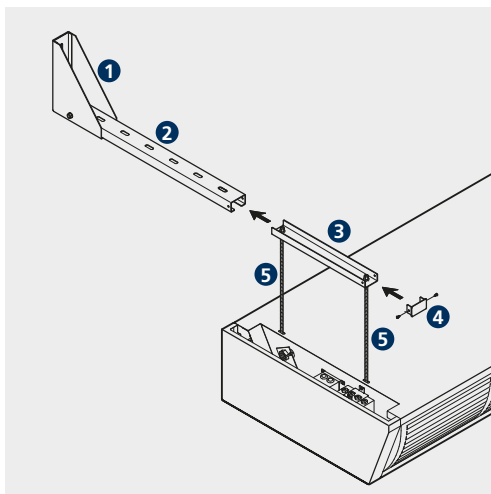

- 1 Fixing bracket for wall bracket
- 2 U-shaped rail
- 3 Slide-in rail
- 4 Cover
- 5 Threaded rod

### Overview of types

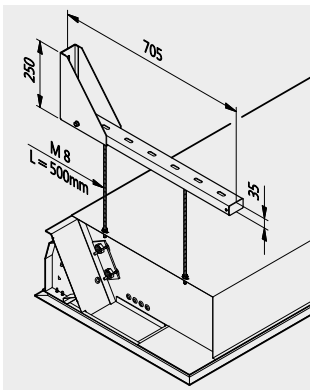

Wall bracket, example shown  
Tandem 300

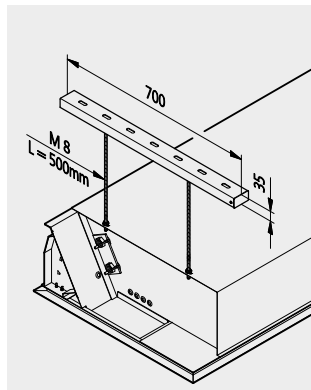

Ceiling bracket, example shown  
Tandem 300

- ▶ Adjustable towards the door
- ▶ Brackets powder coated traffic white RAL 9016
- ▶ Precise height adjustment is possible with the use of threaded rods

### Slot-in design for wall and ceiling brackets

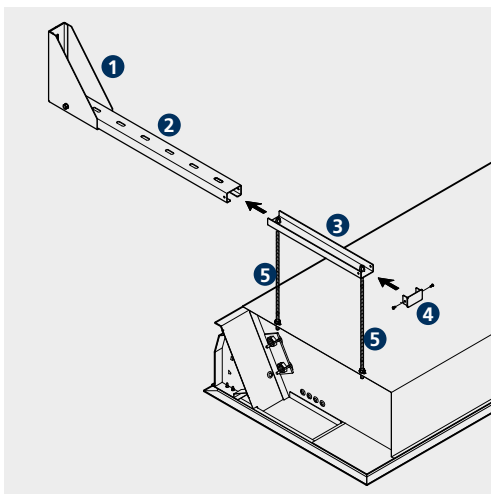

- 1 Fixing bracket for wall bracket
- 2 U-shaped rail
- 3 Slide-in rail
- 4 Cover
- 5 Threaded rod

### Overview

Door air curtain	Model	Wall bracket	Ceiling bracket
Tandem 300	Model 12–25	Type 100990	Type 100995
	Model 30	Type 100992	Type 100997
Tandem 300 ceiling cassette unit	Model 12–25	Type 100990	Type 100995
	Model 30	Type 100992	Type 100997
Tandem 365	Model 12–20	Type 200890	Type 200895
	Model 27	Type 200892	Type 200897

## Tandem 300: Fixing points and connection area

Tandem door air curtains are either suspended using wall and ceiling brackets or a bracket on site.  
4 no. slots (additionally 2 no. M8 rivet nuts for model 30) are fitted to the unit.  
The LPHW and electrical connection is located on the

upper side of the unit behind the side panel, on the left-hand side, seen from the air intake.  
Dimensions and spacings can be taken from the following drawings and table.

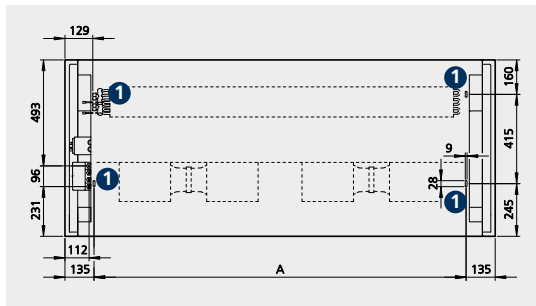

Top view

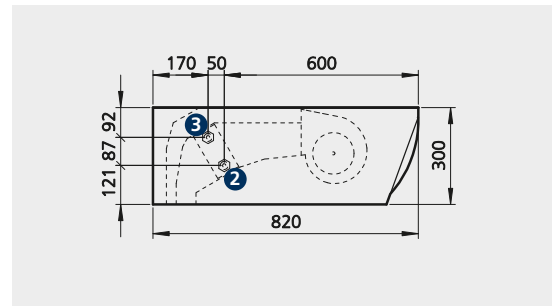

Side view

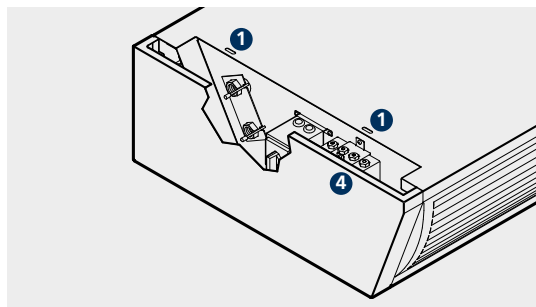

Isometric view, connection area

- 1 Fixing point
- 2 Flow 3/4"
- 3 Return 3/4"
- 4 Electrical connection

The side panel can be removed without the need for a tool to access the electrical wiring, PCB settings, for permanent decommissioning, valve adjustment or for

maintenance purposes, providing access for all connection work.

### Spacing of fixing points (dimensions in mm)

Model	A
	[mm]
12	980
20	1730
25	2230
30	2 x 1365

# Tandem 300 recessed ceiling unit:

## Fixing points

Tandem ceiling cassette door air curtains are either suspended using wall and ceiling brackets or a bracket on site. 4 no. slots (additionally 2 no. M8 rivet nuts for model 30) are fitted to the unit.

Dimensions and spacings can be taken from the following drawings and table.

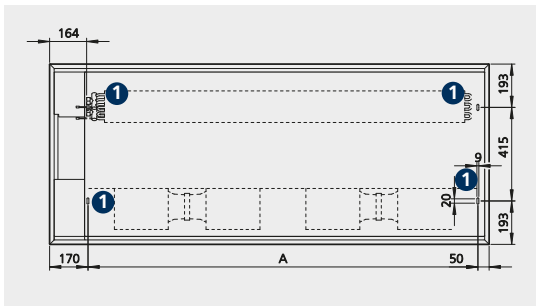

Top view

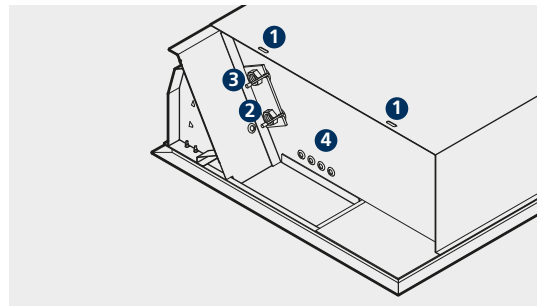

Isometric view, connection area

- 1 Fixing point
- 2 Flow 3/4"
- 3 Return 3/4"
- 4 Cable openings

### Spacing of fixing points (dimensions in mm)

Model	A
	[mm]
12	980
20	1730
25	2230
30	2 x 1365

## Tandem 300 recessed ceiling unit: Connection area

The LPHW connection is located on the side of the unit, on the left-hand side, seen from the air intake. Valves can be adjusted and the heat exchanger vented through the service hatch. The electrical connection is located on the underside of the unit, on the left-hand side, seen from the air intake.

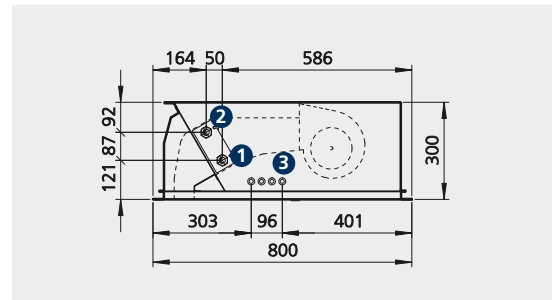

Side view

The electrical junction box can be hinged downwards and fixed to the side bracket (with C1 and T control configuration) to access the electrical wiring, PCB settings, for permanent decommissioning or for maintenance.

Fit the valves before completing the ceiling (plasterboard ceiling or acoustic ceiling grid etc.). The valves can be adjusted and the heat exchanger vented through the service hatch.

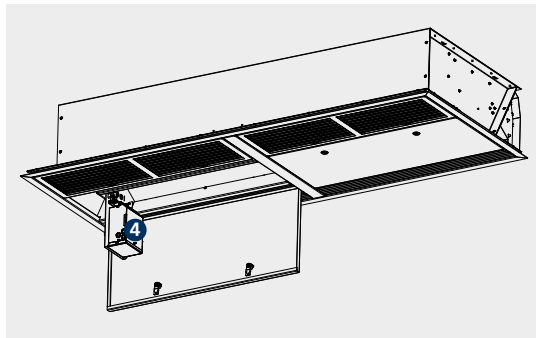

General view, electrical connection (e.g. Model 20, C1 control configuration)

- ① Flow 3/4"
- ② Return 3/4"
- ③ Cable openings
- ④ Electrical junction box (e.g. C1 control configuration)

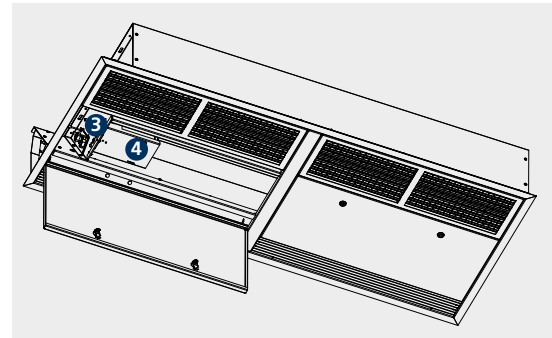

General view, LPHW connection (e.g. Model 20, C1 control configuration)



# Tandem 365:

## Fixing points and connection area

Tandem door air curtains are either suspended using wall and ceiling brackets or a bracket on site. 4 no. slots (additionally 2 no. M8 rivet nuts for model 27) are fitted to the unit.

The LPHW and electrical connection is located on the

upper side of the unit behind the side panel, on the left-hand side, seen from the air intake.

Dimensions and spacings can be taken from the following drawings and table.

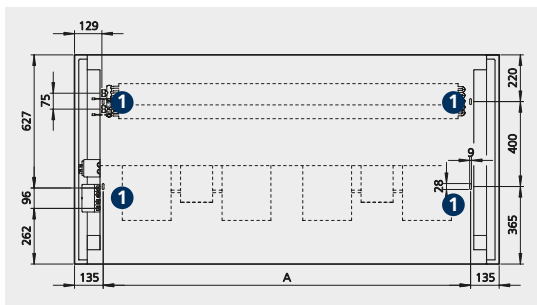

Top view

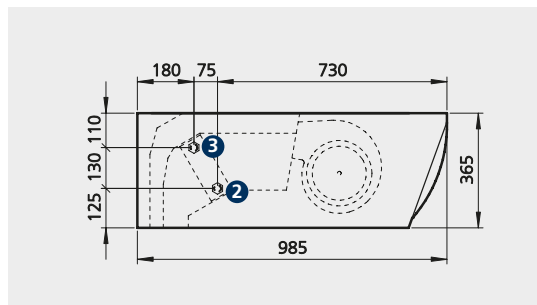

Side view

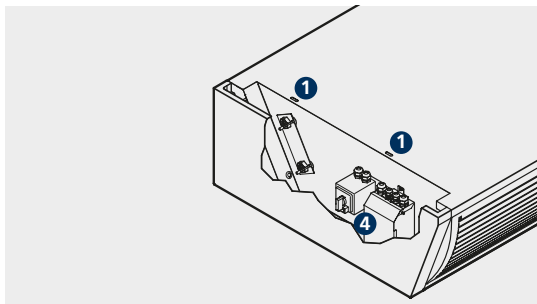

Isometric view, connection area

- 1 Fixing point
- 2 Flow 3/4"
- 3 Return 3/4"
- 4 Electrical connection

The side panel can be removed without the need for a tool to access the electrical wiring, PCB settings, for permanent decommissioning, valve adjustment or for

maintenance purposes, providing access for all connection work.

### Spacing of fixing points (dimensions in mm)

Model	A
	[mm]
12	980
20	1730
27	2 x 1240

# 04 ▶ Controls

---

## Control valves

### Outlet air temperature limiting valve



The discharge temperature is a key factor for the effectiveness of a door air curtain. Too high outlet air temperatures reduce the penetration depth of the air stream and can have an unpleasant effect. For energy-saving reasons, the outlet temperature should not be higher than 40 °C during the heating season: a temperature of between 32 °C and 36 °C is recommended according to VDI 2082.

The outlet temperature limiting valve offers the opportunity to limit the outlet temperature. The limit is adjusted on the valve itself.

### Thermoelectric shut-off valve



A warm air stream is not needed with warm outside temperatures in summer. In the same way, when switched off, the warm medium should not flow through the heat exchanger. The use of an NC 230 V AC shut-off valve therefore makes sense in terms of energy use.

## Control – Tandem EC, electromechanical model

### Product features

The EC fan is connected to terminals with the Tandem EC electromechanical model of door air curtain. There is also an option to connect a 230 V DC thermoelectric shut-off valve.

Tandem door air curtains (EC electromechanical) are available in two models:

- Option 1: Electromechanical without fault alarm contact (type ending in \*00)
- Option 2: Electromechanical with fault alarm contact (type ending in \*T)

### Fans

The speed of EC fans used in Tandem EC door air curtains is continuously variable controlled by a 0-10 V DC signal. The "intelligent" motor electronics detects any possible motor fault and automatically switched the fan off.

Only with version 2, electromechanical with fault alarm contact: A potential-free alarm contact wired to terminals offers the option of calling up and displaying the motor fault on any control units that may be connected.

### Operating units

Two different operating units are available for operation and control.

#### Speed controller type 30510



The speed controller offers the simplest method of continuously variable fan speed control:

- ▶ large button to activate and adjust the speed
- ▶ limit of minimum and maximum speed via internal trimmer
- ▶ surface-mounted (degree of protection IP54) or flush-mounted (degree of protection IP44)

Important: The thermoelectric shut-off valve cannot be controlled.

### Combined controller type 30158



The combined controller offers all key functions required for a door air curtain:

- ▶ Large button to activate and adjust the basic speed.
- ▶ Operating mode selector for mode switch-over between Standby, Heating(winter), Ventilation (summer).
- ▶ Door contact control input for automatic speed increase.
- ▶ Control input to detect any possible motor fault.
- ▶ Room temperature control as back-up in the event of absence (mode switch to Heating and button to "0").
- ▶ Optional use of an internal or external room temperature sensor (accessory).
- ▶ Three-coloured LED control for operating modes and signals.
- ▶ Surface-mounted installation on a flush back box or using surface-mounted frame (accessory).
- ▶ Surface-mounted installation without back box.

### Operating using on-site systems

Control via analogue and digital signals is also possible as an alternative to the Kampmann operating units. The following analogue and digital inputs and / or outputs are needed:

- ▶ Speed control via a 0-10 V DC signal. The fan starts up safely at 1.5 V DC.
- ▶ 230 V AC switch output for control of a thermoelectric shut-off valve.
- ▶ Control input for the detection of any possible motor fault (only with electromechanical door air curtains with fault signal contact \*T).

### Information on operation via a door contact

If the fan is activated from idle by a door contact, a certain time is needed before a door air curtain can provide actual screening. Therefore when operated by a door contact with a closed door, the fan should run at basic speed and the speed increased when the door opens. An appropriate run-on at a higher speed should be provided once the door has closed.

# Electrical installation of Tandem EC, electromechanical without fault signal contact (\*00), control by speed controller type 30510

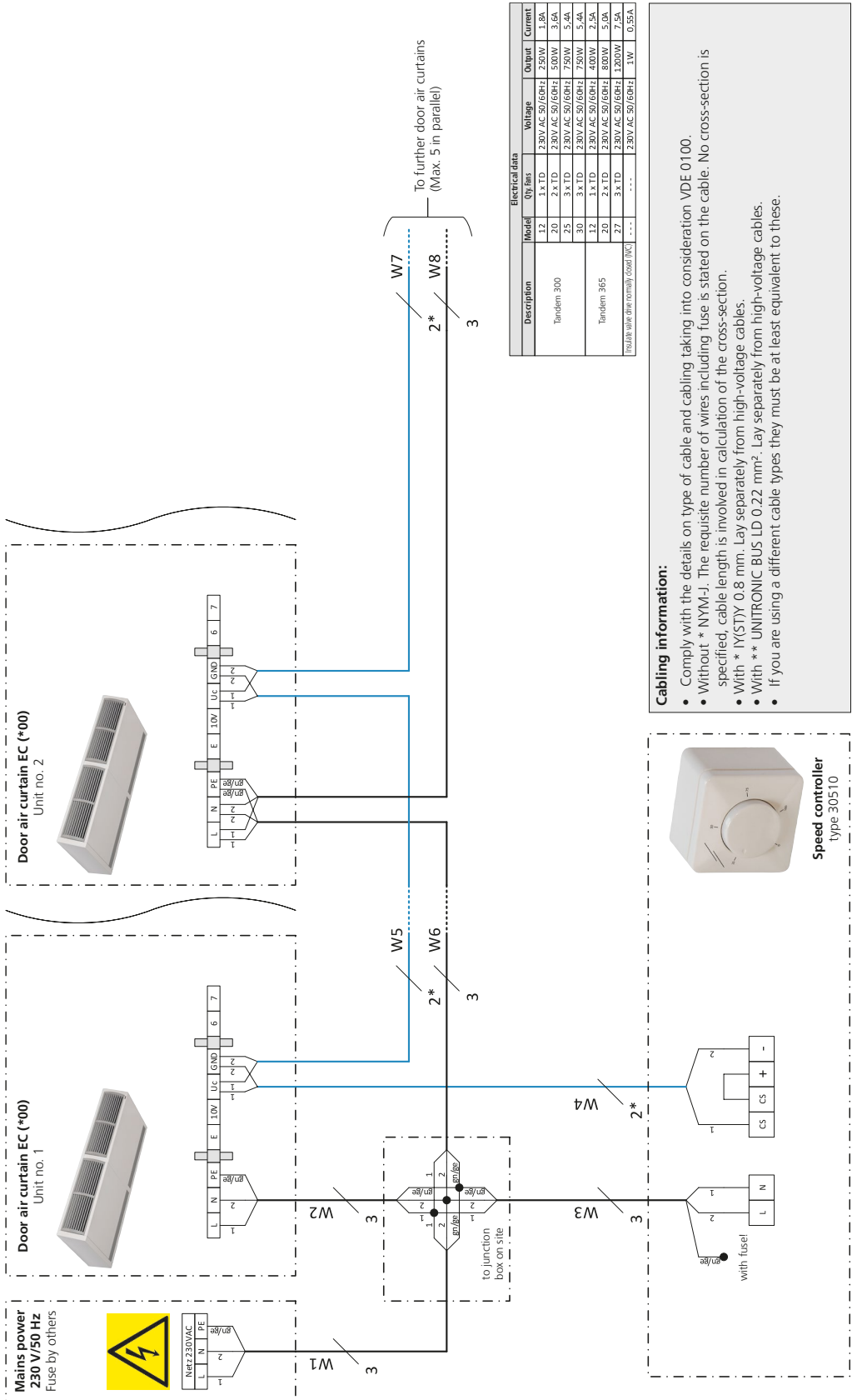

# Electrical installation – Tandem EC door air curtain, electromechanical, without fault signal contact (\*00), control by combined controller type 30158

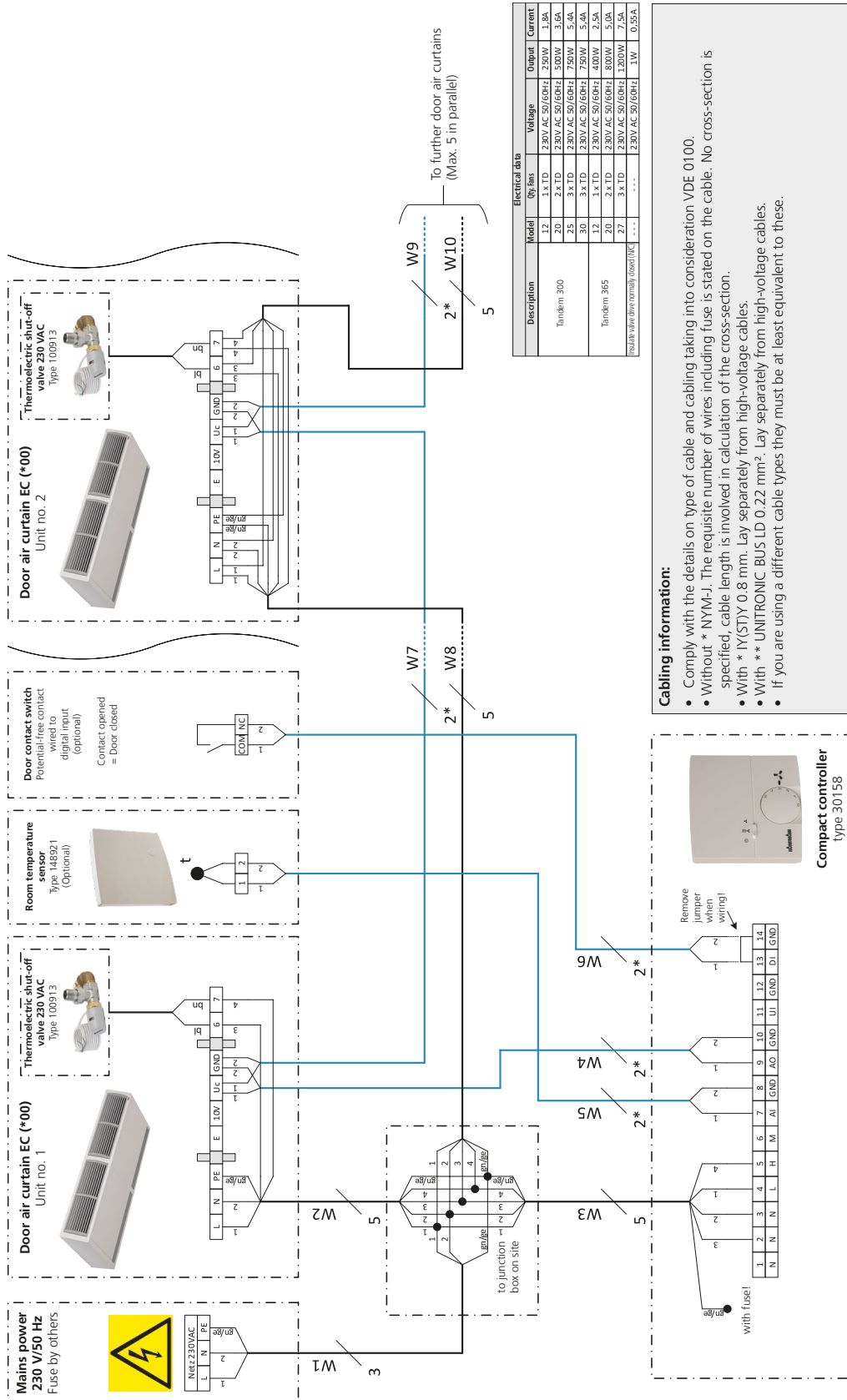

**Cabling information:**

- Comply with the details on type of cable and cabling taking into consideration VDE 0100.
- Without \* NYM-J. The requisite number of wires including fuse is stated on the cable. No cross-section is specified, cable length is involved in calculation of the cross-section.
- With \* Y(Y)STY 0.8 mm. Lay separately from high-voltage cables.
- With \*\* UNITRONIC BUS LD 0.22 mm<sup>2</sup>. Lay separately from high-voltage cables.
- If you are using a different cable types they must be at least equivalent to these.

# Electrical installation – Tandem EC door air curtain, electromechanical, without fault signal contact (\*00), DDC/BMS control

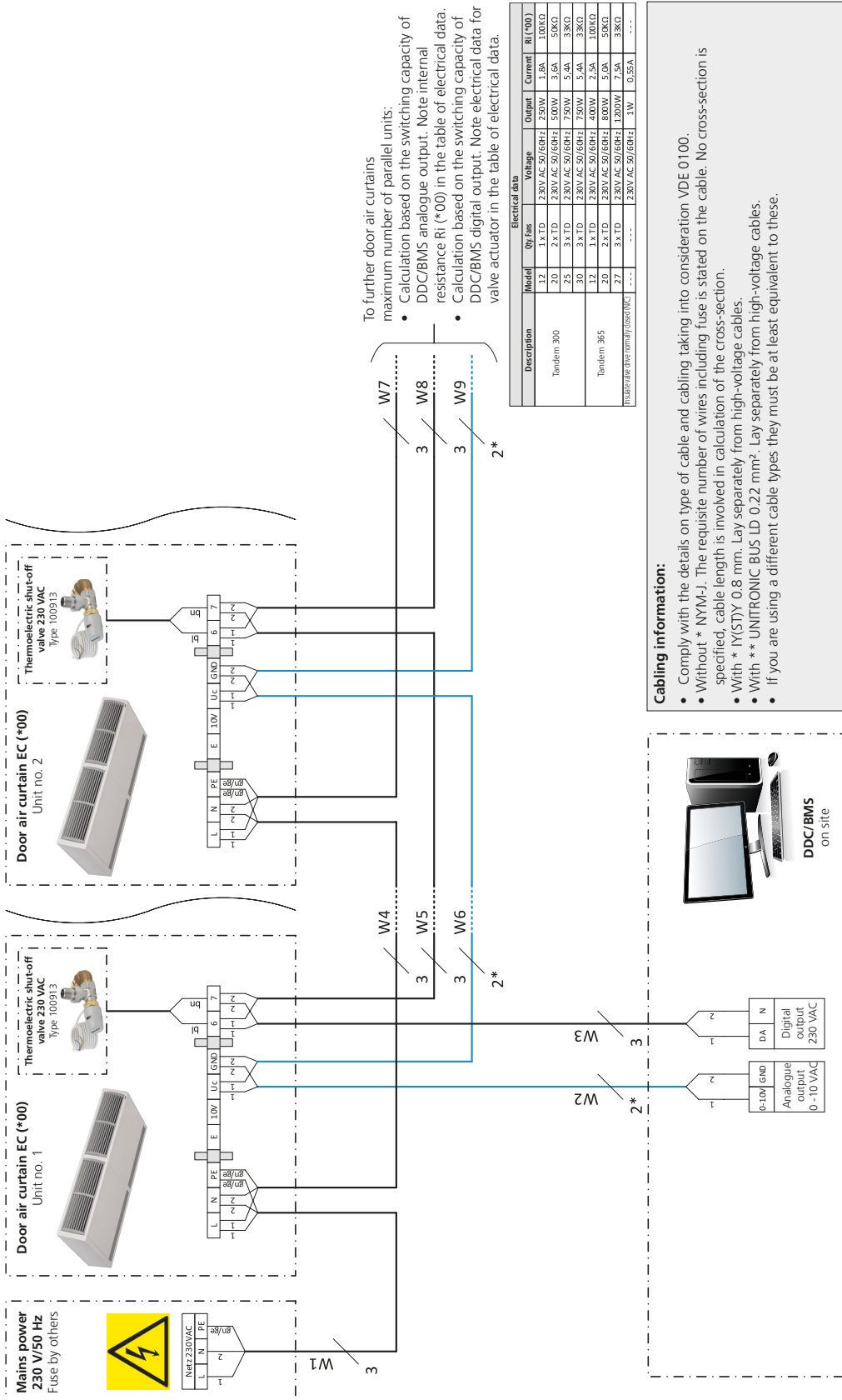

To further door air curtains maximum number of parallel units:

- Calculation based on the switching capacity of DDC/BMS analogue output. Note internal resistance Ri (\*00) in the table of electrical data.
- Calculation based on the switching capacity of DDC/BMS digital output. Note electrical data for valve actuator in the table of electrical data.

**Cabling information:**

- Comply with the details on type of cable and cabling taking into consideration VDE 0100.
- Without \* NYM-J. The requisite number of wires including fuse is stated on the cable. No cross-section is specified, cable length is involved in calculation of the cross-section.
- With \* IY(STY) 0.8 mm. Lay separately from high-voltage cables.
- With \* UNITRONIC BUS LD 0.22 mm<sup>2</sup>. Lay separately from high-voltage cables.
- If you are using a different cable types they must be at least equivalent to these.

# Electrical installation – Tandem EC door air curtain, electromechanical, with fault signal contact (\* T), Control by speed controller type 30510

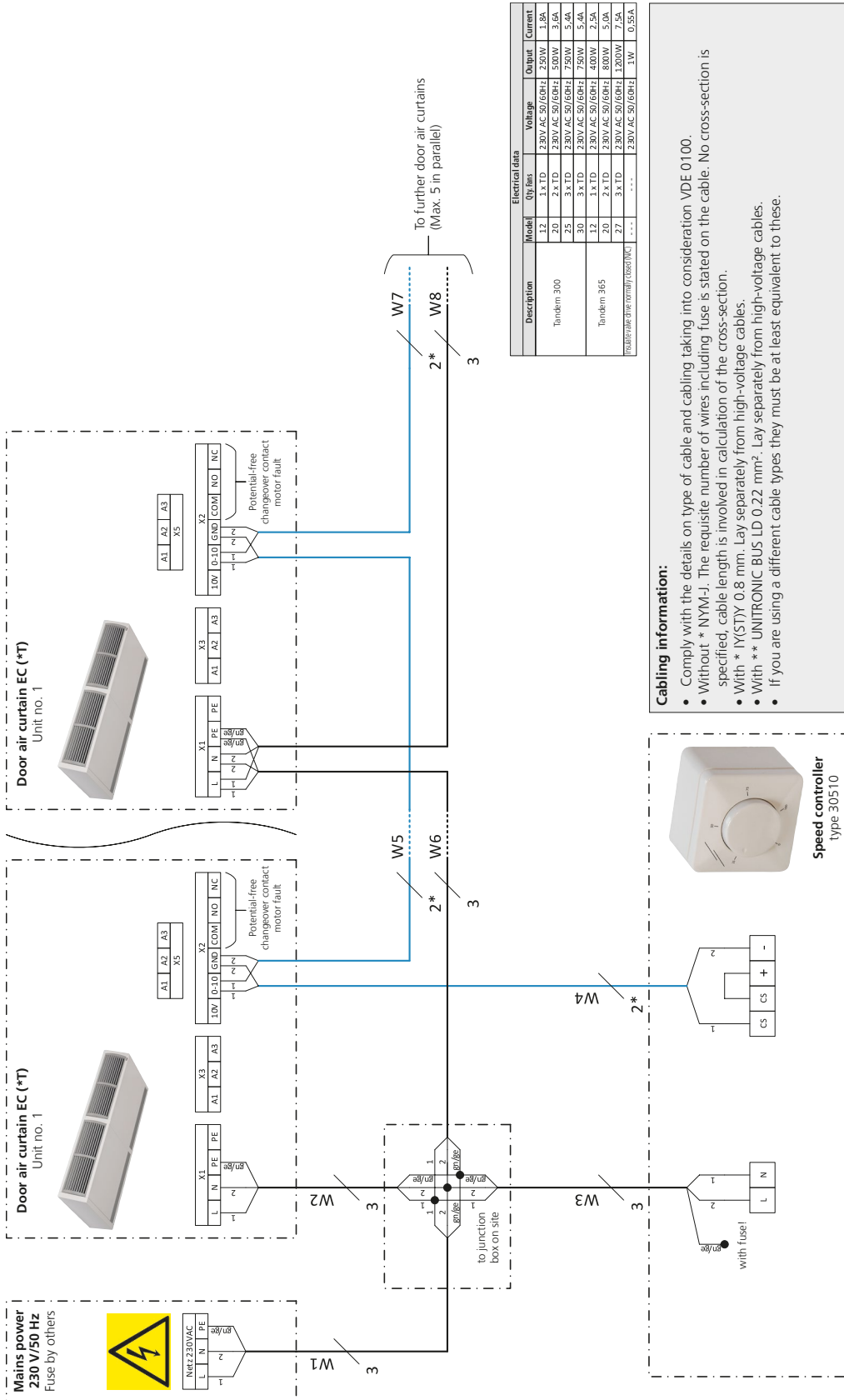



# Electrical installation – Tandem EC door air curtain, electromechanical, with fault signal contact (\* T), control by combined controller type 30158

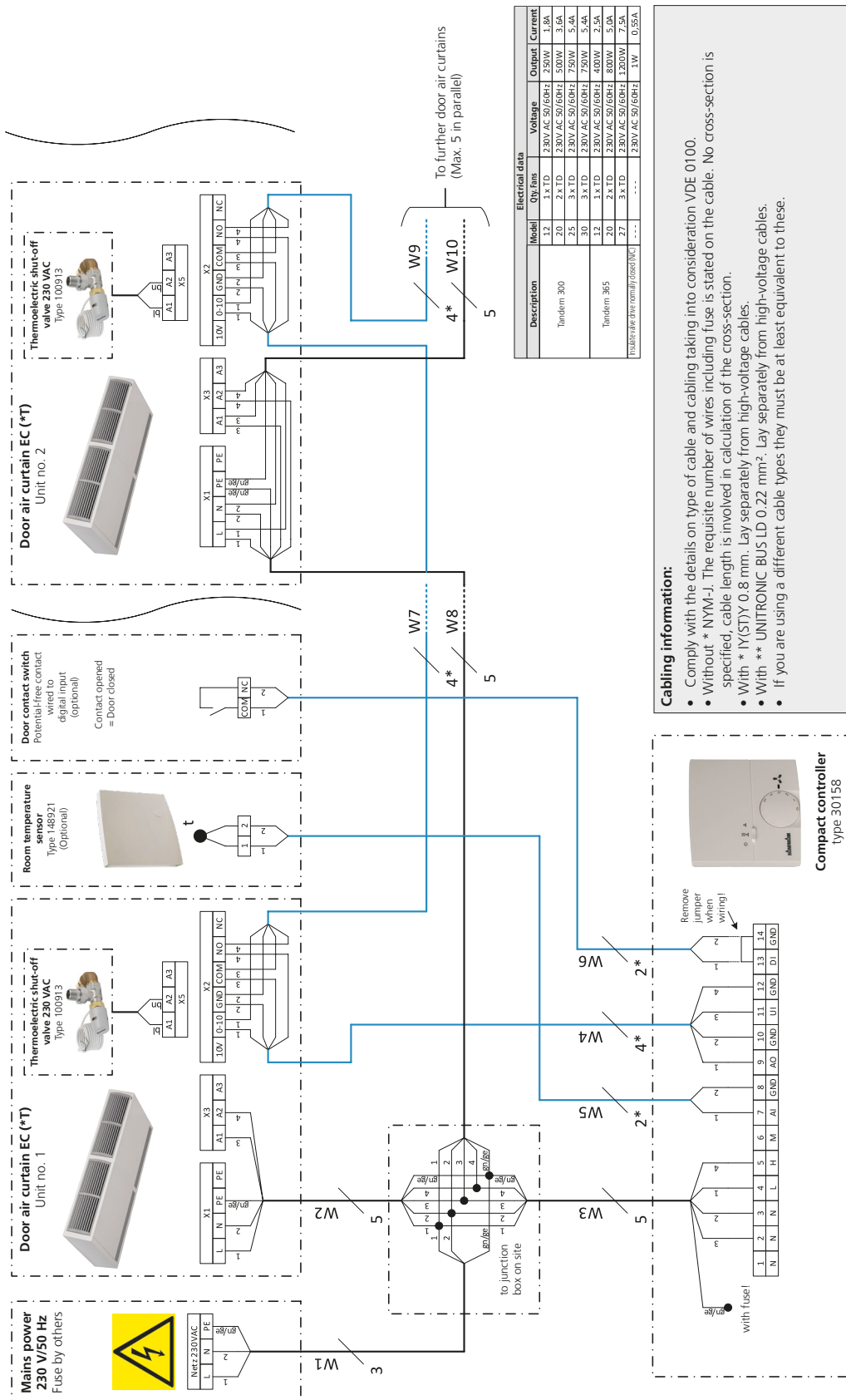

# Electrical installation

## Tandem EC door air curtain, electromechanical, with fault signal contact (\* T), DDC/BMS control

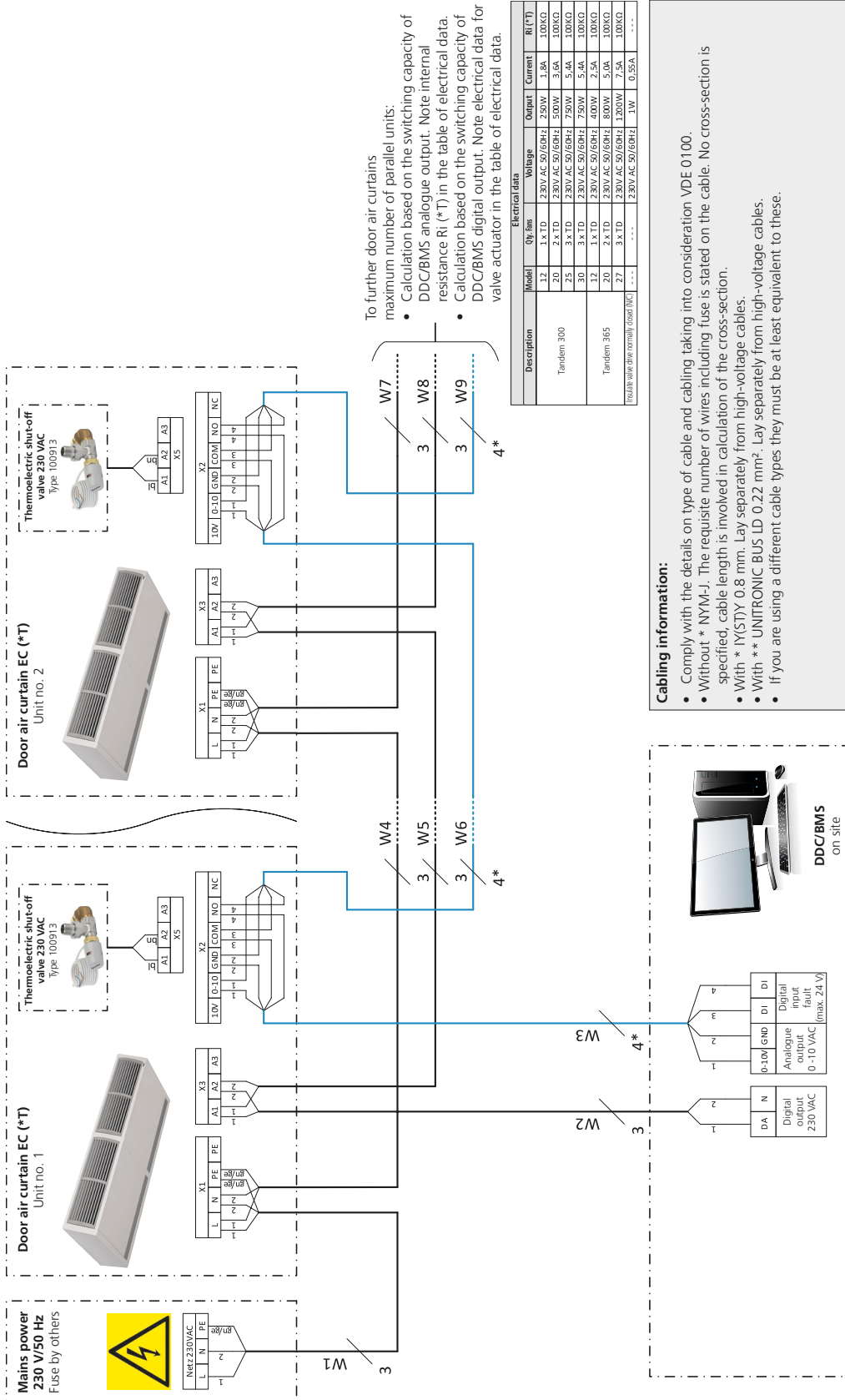

To further door air curtains maximum number of parallel units:

- Calculation based on the switching capacity of DDC/BMS analogue output. Note internal resistance Ri (\*T) in the table of electrical data.
- Calculation based on the switching capacity of DDC/BMS digital output. Note electrical data for valve actuator in the table of electrical data.

**Cabling information:**

- Comply with the details on type of cable and cabling taking into consideration VDE 0100.
- Without \* NYM-J. The requisite number of wires including fuse is stated on the cable. No cross-section is specified, cable length is involved in calculation of the cross-section.
- With \* Y(STY) 0.8 mm. Lay separately from high-voltage cables.
- With \*\* UNITRONIC BUS LD 0.22 mm<sup>2</sup>. Lay separately from high-voltage cables.
- If you are using a different cable types they must be at least equivalent to these.

# Control – Tandem EC, KaControl model

## The all-inclusive solution!

### Product features

Tandem EC door air curtain with KaControl (\*C1) are supplied factory-fitted with all electrical parts ready for connection (with the exception of optional accessories).

The built-in, high-performance, parametrisable KaControl microprocessor control provides all the functions the door air curtain needs.

The “face” of the KaControl is the KaController operating unit.

A group of up to six door air curtains can be formed using a KaController unit without the need for additional addressing.

Optional plug-in interface cards offer the option of connecting to higher-level control systems.

### Fans

The speed of the EC fans used in Tandem EC door air curtains is controlled by a 0-10 V DC signal from the KaControl. The “intelligent” motor electronics detects any possible motor fault and automatically switches the fan off and signals it to the KaControl.

### Control unit

The KaController operating unit is available for operation and control. It represents the face of the KaControl.

### KaController type 3210002



The KaController offers maximum operating convenience with a large display, one-touch operation and side operating keys for quick access.

Based on the principle of “as little as possible, as much as required”, even untrained users can intuitively get to grips with the control options.

The basic functions are set in a user-friendly way using the KaController.

### Product features of the KaController

- ▶ high-quality designed wall-mounted room operating units
- ▶ plastic housing, colour similar to RAL 9010
- ▶ large LCD multifunctional display with energy-saving, automatic LED background lighting
- ▶ integral temperature sensor
- ▶ push-turn navigator dial with endless turn/lock function
- ▶ side operating keys for quick access
- ▶ individually adjustable basic display
- ▶ display of fault messages
- ▶ built-in weekly switching program
- ▶ password-protected parameter level

### **KaControl**

The parametrisable KaControl microprocessor control offers a wealth of functions. The following default settings are factory set for the door air curtain:

- ▶ remote ON/OFF for activation via external NO contact at digital input DI1
- ▶ basic stage can be set using the KaController operating unit
- ▶ door contact to increase speed including run-on function at DI2
- ▶ ECO mode (room temperature control) can be activated when the door is closed using a key or optional KaController timer program
- ▶ optional use of an internal or external room temperature sensor (accessory)
- ▶ heating (winter) / ventilation (summer) switch-over to close thermoelectric shut-off valve in summer using KaController mode key
- ▶ room frost protection at a room temperature of  $< 8^{\circ}\text{C}$
- ▶ any alert that occurs, such as a motor fault, is detected by the KaControl and issued on the KaController
- ▶ potential-free, changeover contact wired to terminals for the signalling of internal information to external systems (refer to instructions for parametrisable function, unit alert default setting)

Any additional functions required can be parametrised and correspondingly coordinated.

### **Information on operation via a door contact**

If the fan is activated from idle by a door contact, a certain time is needed before a door air curtain can provide actual screening. Therefore when operated by a door contact with a closed door, the fan should run at basic speed and the speed increased when the door opens. Allow for an appropriate run-on at a higher speed once the door has closed.

# Electrical installation Tandem EC door air curtains KaControl activation (C1)

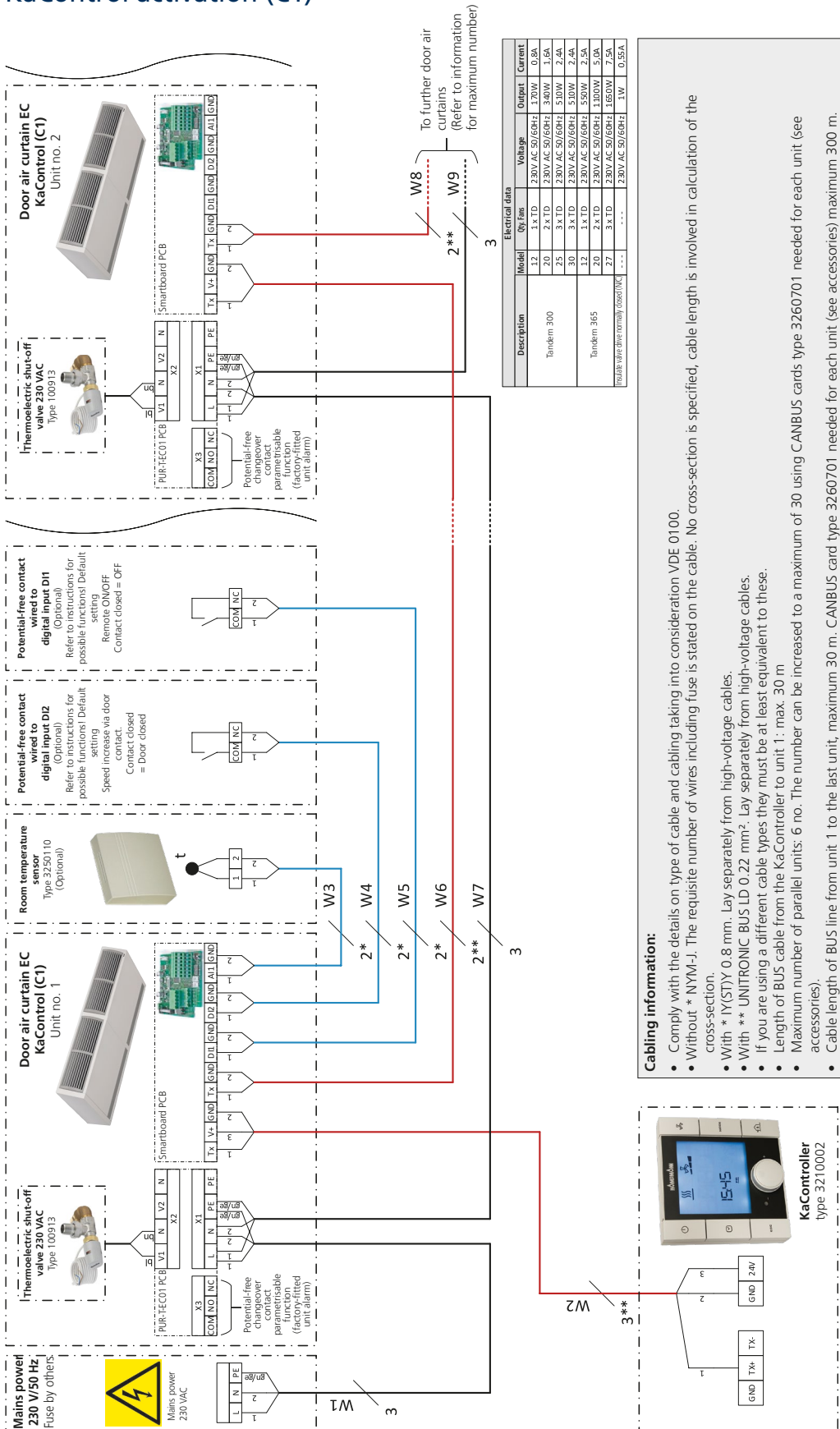

**Cabling information:**

- Comply with the details on type of cable and cabling taking into consideration VDE 0100.
- Without \* NYM-J. The requisite number of wires including fuse is stated on the cable. No cross-section is involved in calculation of the cross-section.
- With \* IY(STY) 0.8 mm. Lay separately from high-voltage cables.
- With \*\* UNITRONIC BUS LD 0.22 mm<sup>2</sup>. Lay separately from high-voltage cables.
- If you are using a different cable types they must be at least equivalent to these.
- Length of BUS cable from the KaController to unit 1: max. 30 m
- Maximum number of parallel units: 6 no. The number can be increased to a maximum of 30 using CANBUS cards type 3260701 needed for each unit (see accessories).
- Cable length of BUS line from unit 1 to the last unit, maximum 30 m. CANBUS card type 3260701 needed for each unit (see accessories) maximum 300 m.

## KaControl – integration into intelligent building networks (IoT)

KaControl offers a wealth of options for integration into established communication networks. Various building automation strategies can be configured using various options.

### **Individual switching of units**

Units with KaControl configuration can be directly integrated into on-site networks using optional communication interfaces. Control and monitoring is provided via fixed data points. Operation is provided via the KaController operating unit or via the operating units that belong to the network.

### **Switching of groups**

Up to six units with KaControl configuration can be operated in a single group. Groups of units can be directly integrated into on-site networks using optional communication interfaces. Control and monitoring is provided via fixed data points. Operation of a group is provided via the KaController operating unit or via the operating units that belong to the network.

### **Communication interfaces**

The following communication interfaces can be supplied separately of factory-fitted.

- ▶ Modbus RTU
- ▶ KNX
- ▶ BACnet IP

### **Important:**

More information on integration into intelligent building networks and the associated communication interfaces is available on request!



# 05 ▶ Ordering Information

## Tandem 300 door air curtain

Model	Max. discharge height <sup>1)</sup>	Unit model	Length <sup>2)</sup>	Heat output <sup>3)</sup>	Air volume <sup>4)</sup>	Sound pressure level <sup>5)</sup>	Sound power level	Control option	Art. no.
	[m]		[mm]	[kW]	[m <sup>3</sup> /h]	[dB(A)]	[dB(A)]		
12	2.7 – 3.2	Tandem 300	1250	4.6 – 9.6	700 – 2030	32 – 61	48 – 77	electro-mechanical	251003112430
								electro-mechanical with fault signal monitoring	251003112430T
								KaControl	251003112430C1
		Tandem 300 ceiling cassette unit	1200	4.6 – 9.6	700 – 2030	32 – 61	48 – 77	electro-mechanical	251003312430
								electro-mechanical with fault signal monitoring	251003312430T
								KaControl	251003312430C1
20	2.7 – 3.2	Tandem 300	2000	8.3 – 18.5	1200 – 3830	35 – 63	51 – 79	electro-mechanical	251003120430
								electro-mechanical with fault signal monitoring	251003120430T
								KaControl	251003120430C1
		Tandem 300 ceiling cassette unit	1950	8.3 – 18.5	1200 – 3830	35 – 63	51 – 79	electro-mechanical	251003320430
								electro-mechanical with fault signal monitoring	251003320430T
								KaControl	251003320430C1
25	2.7 – 3.2	Tandem 300	2500	10.8 – 26.5	1480 – 5410	37 – 63	53 – 79	electro-mechanical	251003125430
								electro-mechanical with fault signal monitoring	251003125430T
								KaControl	251003125430C1
		Tandem 300 ceiling cassette unit	2450	10.8 – 26.5	1480 – 5410	37 – 63	53 – 79	electro-mechanical	251003325430
								electro-mechanical with fault signal monitoring	251003325430T
								KaControl	251003325430C1
30	2.7 – 3.2	Tandem 300	3000	13.5 – 30.1	1850 – 5810	37 – 65	53 – 81	electro-mechanical	251003130430
								electro-mechanical with fault signal monitoring	251003130430T
								KaControl	251003130430C1
		Tandem 300 ceiling cassette unit	2950	13.5 – 30.1	1850 – 5810	37 – 65	53 – 81	electro-mechanical	251003330430
								electro-mechanical with fault signal monitoring	251003330430T
								KaControl	251003330430C1

[more »](#)

<sup>1)</sup> at low to medium pressure, requirements and conditions, see page 21

<sup>2)</sup> including casing elements

<sup>3)</sup> at LPHW 75/65,  $t_{L1} = 20^{\circ}\text{C}$

<sup>4)</sup> total, continuously variable control

<sup>5)</sup> The sound pressure levels were calculated based on an assumed room insulation of 16 dB(A). This corresponds to a distance of 3 m, a room volume of 2000 m<sup>3</sup> and a reverberation time of 1.0 s (in accordance with VDI 2081)



## Tandem 365 door air curtain

Model	Max. discharge height <sup>1)</sup>	Unit model	Length <sup>2)</sup>	Heat output <sup>3)</sup>	Air volume <sup>4)</sup>	Sound pressure level <sup>5)</sup>	Sound power level	Control option	Art. no.
	[m]		[mm]	[kW]	[m <sup>3</sup> /h]	[dB(A)]	[dB(A)]		
12	3.2 – 4.0	Tandem 365	1250	7.1 – 14.3	1090 – 3090	33 – 64	49 – 80	electro-mechanical	252003212330
								electro-mechanical with fault signal monitoring	252003212330T
								KaControl	252003212330C1
20	3.2 – 4.0	Tandem 365	2000	12.8 – 27.8	1860 – 5830	37 – 66	53 – 82	electro-mechanical	252003220330
								electro-mechanical with fault signal monitoring	252003220330T
								KaControl	252003220330C1
27	3.2 – 4.0	Tandem 365	2750	18.1 – 41.9	2550 – 8480	38 – 67	54 – 83	electro-mechanical	252003227330
								electro-mechanical with fault signal monitoring	252003227330T
								KaControl	252003227330C1

<sup>1)</sup> at low to medium pressure, requirements and conditions, see page 21



<sup>2)</sup> including casing elements

<sup>3)</sup> at LPHW 75/65,  $t_{L1} = 20^{\circ}\text{C}$

<sup>4)</sup> total, continuously variable control







<sup>5)</sup> The sound pressure levels were calculated based on an assumed room insulation of 16 dB(A). This corresponds to a distance of 3 m, a room volume of 2000 m<sup>3</sup> and a reverberation time of 1.0 s (in accordance with VDI 2081)

## Accessories



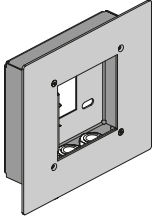

Figure	Article	Properties	Suitable for		Art. no.
<b>Filter</b>					
	<b>Filter with frame</b>	1 no. (2 required with Model 20 and larger), filter class: ISO Coarse	Tandem 300, Tandem 300 ceiling cassette unit	Model 12	<b>251003112925</b>
				Model 20	<b>251003120925</b>
				Model 25	<b>251003125925</b>
				Model 30	<b>251003130925</b>
			Tandem 365	Model 12	<b>252003212825</b>
				Model 20	<b>252003220825</b>
Model 27	<b>252003227825</b>				
<b>brackets</b>					
	<b>Wall brackets</b>	1 set = 2 brackets	Tandem 300, Tandem 300 ceiling cassette unit	Model 12 – 25	<b>251000100990</b>
		1 set = 3 brackets		Model 30	<b>251000100992</b>
		1 set = 2 brackets	Tandem 365	Model 12 – 20	<b>252000200890</b>
		1 set = 3 brackets		Model 27	<b>252000200892</b>
	<b>Ceiling brackets</b>	1 set = 2 brackets	Tandem 300, Tandem 300 ceiling cassette unit	Model 12 – 25	<b>251000100995</b>
		1 set = 3 brackets		Model 30	<b>251000100997</b>
		1 set = 2 brackets	Tandem 365	Model 12 – 20	<b>252000200895</b>
		1 set = 3 brackets		Model 27	<b>252000200897</b>
<b>Sheet steel accessories/Casing extension</b>					
	<b>Connecting kit for unit extension</b>	To connect several Tandem 300 or Tandem 365, powder-coated, RAL 9016 traffic white	Tandem 300	All models	<b>251003100910</b>
			Tandem 365		<b>252003200810</b>

[more »](#)

## Control accessories for Tandem door air curtains

Figure	Article	Properties	suitable for	Art. no.
<b>Valves</b>				
	<b>Thermoelectric shut-off valve</b>	230 V, 3/4" Important: Cannot be controlled by speed controller type 30510	All Tandem door air curtains	<b>196000100913</b>
	<b>Outlet air temperature limiting valve</b>	3/4", Temperature setting range 20–50°C		<b>196000103968</b>
<b>Control accessories for electromechanical control (*00) and electromechanical control with fault signal evaluation (*T)</b>				
	<b>Speed controller</b>	For the continuously variable speed control, surface-mounted and flush-mounted, no control of the thermoelectric shut-off valve is possible	All Tandem door air curtains with control version *00 and *T	<b>196000030510</b>
	<b>Combined controller</b>	Combined controller for fan speed control and room temperature control, surface-mounted on back box or on surface-mounted frame 196000030159	All Tandem door air curtains with control version *00 and *T	<b>196000030158</b>
	<b>Surface-mounted frame</b>	For surface mounting of the combined controller 196000030158 if no back box is possible.	All Tandem door air curtains with control version *00 and *T	<b>19600030159</b>
	<b>Room temperature sensor</b>	Wall-mounted, surface-mounted, IP30, colour pure white, similar to RAL 9010, optionally to the temperature sensor in the climate controller type 30158	All Tandem door air curtains with control option *00 and *T	<b>196000148921</b>

## Control accessories for Tandem door air curtains

Figure	Article	Properties	suitable for	Art. no.
<b>KaControl accessories</b>				
	<b>KaController operating unit</b> with one-touch operation and side operating keys	Room control unit, wall-mounted, in high-grade design, plastic housing, colour similar to RAL 9010, large LCD multifunctional display, integrated room temperature sensor, communication interface to Kampmann T-LAN bus system, automatically switching LED backlight, press/turn dial with endless click/stop function, side operating keys for easy access to fan setting, operating modes, Eco mode, time and built-in day, night and weekly switching programme, individually adjustable basic display, password-protected parametrisation level	All Tandem door air curtains with KaControl configuration (*C1)	<b>196003210002</b>
	<b>Surface-mounted frame for KaController</b>	For surface-mounted installation of the KaController type 3210002		<b>197901081889</b>
	<b>KaControl room temperature sensor</b>	For wall mounting, IP30 surface-mounted, colour white RAL 9010, alternative to the temperature sensor in the KaController		<b>196003250110</b>
	<b>KaControl outdoor sensor configured as industrial room sensor</b>	For wall mounting, IP65 surface-mounted, white RAL 9010, alternative to the temperature sensor in the KaController		<b>196003250112</b>
	<b>Serial CANBus card</b>	To increase the number of units from 6 units to up to 30 units in a control circuit and/or extend the cable length of the BUS cable between the first and last unit from 30 m to 300 m		<b>196003260301</b>







[Kampmann.co.uk/tandem](https://Kampmann.co.uk/tandem)

**Kampmann UK Ltd.**  
Dial House, Govett Avenue  
Shepperton, Middlesex, TW17 8AG  
Great Britain

**T** +44 (0)1932 228592  
**F** +44 (0)1932 228949  
**E** [info@kampmann.co.uk](mailto:info@kampmann.co.uk)  
**W** [Kampmann.co.uk](https://Kampmann.co.uk)

