MF-748x

Electric Terminal Unit Actuator

Product Bulletin

The MF-748x Series provides floating or proportional control in HVAC applications.

The compact design of this actuator makes it suitable for installation in confined spaces, such as fan coil, chilled ceiling, manifolds, etc.

Due to the innovative concept of different strokes setting the MF-748x can be installed over most of the terminal unit valve in the market.



- **Low and line voltage**
Flexible applications
- **Floating and proportional control**
Flexible application
- **Voltage and current analog input**
Suitable for any controller
- **Different analog input ranges**
Flexible applications
- **Different actuator speed**
New market opportunities
- **Double colour LED**
Provide information about status and diagnostic
- **Removable cable**
No expert requires for connection or replacement
- **Different cable length available as separate kit**
OEM's version easily available

Ordering codes

Product code	Power supply	Control type	Actuator speed	Actuator stroke field configurable	Factory stroke configured	Mounting thread nut
MF-7480-0001	24Vac	Floating	13sec/mm	---	---	M30x1,5
MF-7482-1001	24Vac/Vdc	Proportional	8sec/mm	X	3.2mm	

Accessories (order separately)

Accessories code	Description	Packing
VA-7480-CAB21	Floating 24V – 2 meter length	Plastic bag
VA-7480-CAB31	Floating 24V – 3 meter length	
VA-7480-CAB51	Floating 24V – 5 meter length	
VA-7480-CAB71	Floating 24V – 7 meter length	
VA-7480-CAB11	Floating 24V – 10 meter length	
VA-7482-CAB21	Proportional 24V – 2 meter length	
VA-7482-CAB31	Proportional 24V – 3 meter length	
VA-7482-CAB51	Proportional 24V – 5 meter length	
VA-7482-CAB71	Proportional 24V – 7 meter length	

Operation

24Vac floating model (MF-7480-0001)

When the signal is applied to the black and red wires, the actuator stem extends. When the signal is removed the actuator remains in position.

If the signal remains applied to the red wire, the actuator will time out and shut off the motor after approximately 90 seconds (13 sec/mm models).

When the signal is applied to the black and orange wires, the actuator stem retracts. When the signal is removed the actuator remains in position.

If the signal remains applied to the orange wire, the actuator will time out and shut off the motor after approximately 90 seconds (13 sec/mm models).

End of stroke confirmation

When the signal is applied in the same direction, the actuator turns on every 2 hours and drives in the signal direction for approximately 90 seconds (13 sec/mm models) to confirm the end of stroke position.

Input	Direction	
Red wire energised	↓	Actuator stem extends
Orange wire energised	↑	Actuator stem retracts

24Vac/Vdc proportional model (MF-7482-1001)

Calibration cycle

When the power is applied, the actuator self-calibrates performing a complete cycle. The actuator moves the stem down for a complete mechanical valve stroke until no changes are detected. Once the auto-zero is detected the actuator moves the stem accordingly with the input signal.

When the input signal increases (eg. from 0V to 10V) the actuator stem extends if the actuator is configured as Direct Action (DA) or retracts if the actuator is configured as Reverse Action (RA).

When the input signal decreases (eg. from 10V to 0V) the actuator stem retracts if the actuator is configured as Direct Action (DA) or extends if the actuator is configured as Reverse Action (RA).

End of stroke confirmation





When the input signal is at 100% the actuator turns on every 2 hours and drives in the signal direction for approximately 60 seconds to confirm the end of stroke position

Action	Input	Direction	
Direct Acting	0...10Vdc	↓	Actuator stem extends
	10...0Vdc	↑	Actuator stem retracts
Reverse Acting	0...10Vdc	↑	Actuator stem retracts
	10...0Vdc	↓	Actuator stem extends

Operating status indication







24Vac floating model

The floating models are equipped with a green LED which provides the information about the operating status as follow:

OFF		No power supply
GREEN BLINKING		Moving to position
GREEN BLINKING		End stroke confirmation
GREEN STEADY ON		End Stroke reached

24Vac/Vdc proportional model

The proportional models are equipped with a bi-colour LED (green-red) which provides the information about the operating status and diagnostic as follow:

OFF		No power supply
GREEN BLINKING		Moving to position
GREEN BLINKING		End stroke confirmation
GREEN STEADY ON		Position reached
RED BLINKING		Cycle
RED STEADY ON		4/20mA or 2/10Vdc signal lost

Mounting instructions

When mounting the actuator on terminal unit valves, please follows the instruction below:

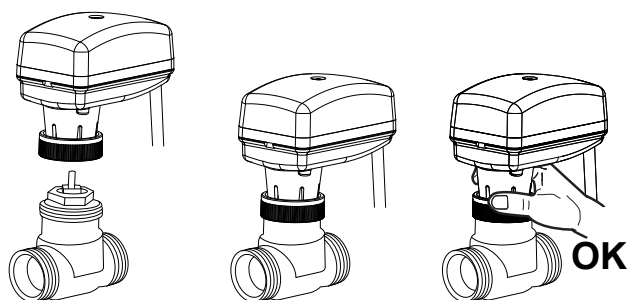

Never use the actuator as a mounting lever.

- It is recommended that the valves be mounted upright or at angles not greater than 90° in an easily accessible location.
- Do not mount the actuator upside down to avoid dripping water, which could enter the housing and damage the mechanism or motor.
- Do not cover with insulating material.
- Sufficient clearance must be allowed for actuator removal (refer to the dimension drawings).

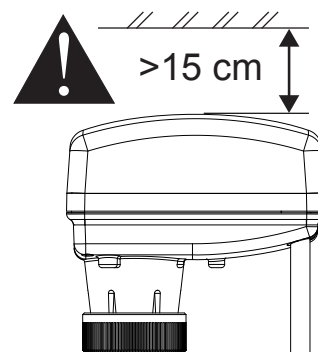

- Mounting position:

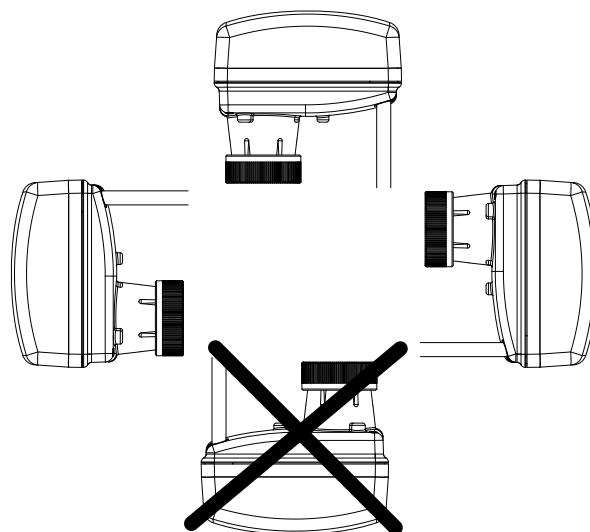

Wiring instructions



WARNING

When servicing make sure that:

- The electric supply to the actuator is switched off to avoid possible damage to the equipment, personal injury or shock.
- You do not touch or attempt to connect or disconnect wires when electric power is on.
- All wiring should conform to local codes and must be carried out by authorized personnel only.
- Keep high and low voltage wiring separated.
- When using multi-stranded wire apply a cable ferrule to the cable end.
- Make sure that the line power supply is in accordance with the power supply specified on the device.
- Check all wiring connections before applying power to the system.
- Contact with components carrying hazardous voltage can cause electric shock and may result in severe injury or death.
- Short-circuited or improperly connected wires may result in permanent damage to the equipment.
- Not adhering to these operational instructions could cause injury or damage the equipment.

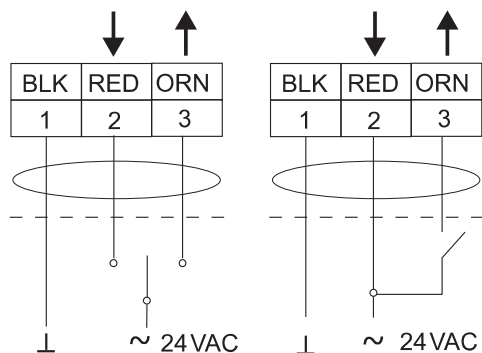

24Vac floating model - wiring diagrams

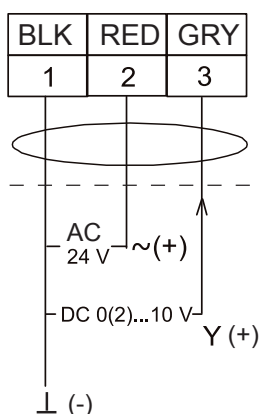

24Vac/Vdc proportional model - wiring diagrams

Dip switch settings for proportional model only (MF-7482)

All the proportional models have a 6 dip switches which allow the user to field configure the actuator. The actuator is factory released with all the dip switches in OFF position.

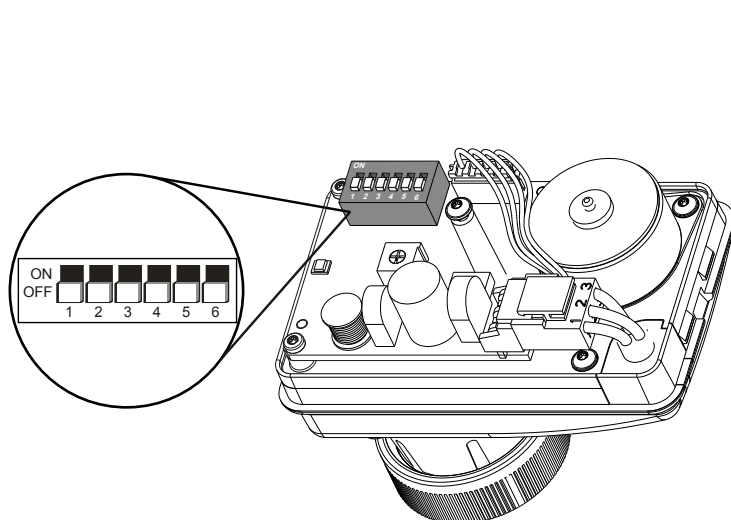

	OFF	ON			
1					
2					
3					
4					
5					
6					

1: CONTROL SIGNAL	4: ACTION
2: RANGE	5: CURVE
3:	6: SIGNAL TYPE

Dip switch 1 – 2 – 3 – 6

The dip switch 1-2-3 allow the user to change the analog input ranges. To switch from voltage analog input to current analog input the dip switch 6 has to be set accordingly.

Dip switch 4

The dip switch 4 allows the user to change the action of the actuator in relation of the analog input.

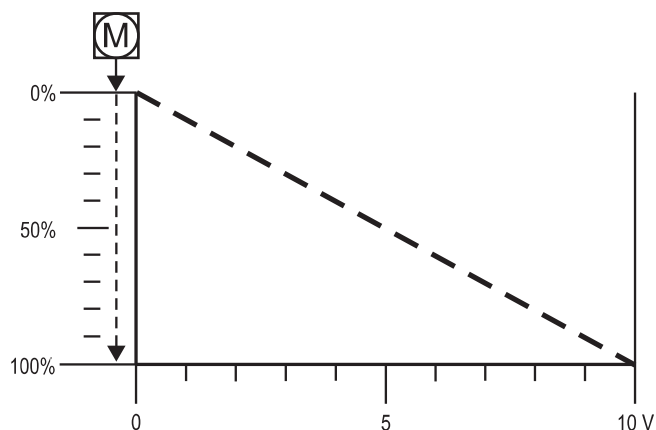

The dip switch 4 OFF (Direct Acting – DA)

When the signal increases the actuator stem extends.

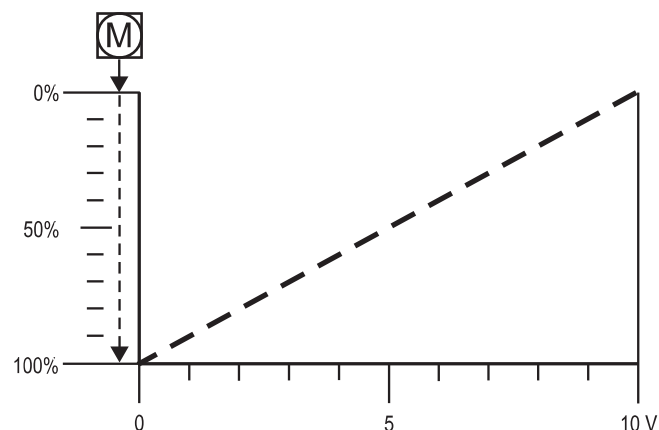

The dip switch 4 ON (Reversing Acting – RA)

When the signal increases the actuator stem retracts.

Dip switch 5

The dip switch 5 allows the user to change the control characteristic of the actuator in order to obtain the a combination of valve and actuator linear or almost equal percentage.

The dip switch 5 OFF (Linear)

We recommend to use with valve with linear or equal percentage control characteristic.

The dip switch 5 ON (almost Equal Percentage)

We recommend to use with valve with quick opening or on/off control characteristic.

Jumper setting for proportional model only (MF-7482)

All the proportional models have 1 jumper which allow the user to change the following parameters:

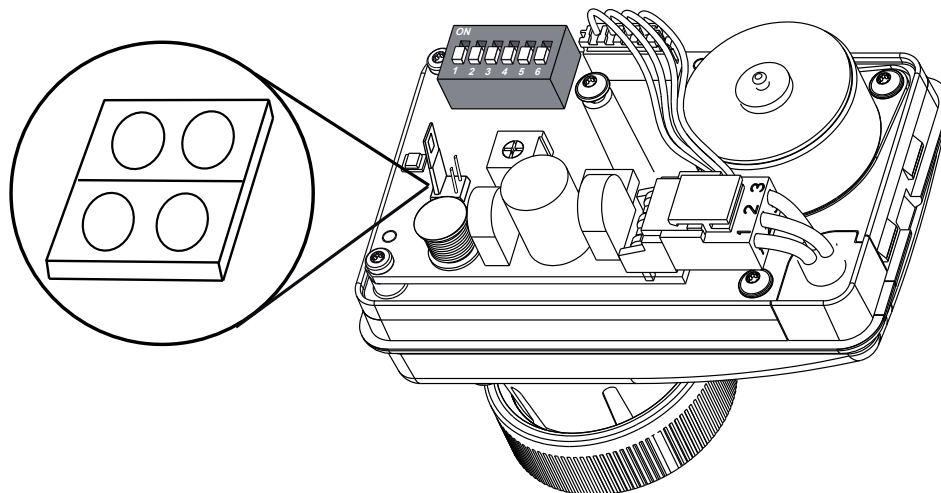

Proportional model MF-7482-1001

The actuator is factory set with stroke 3.2mm but at convenience the stroke can be changed to 4.3mm or 6.0mm in case the same actuator is mounted on a different valve.

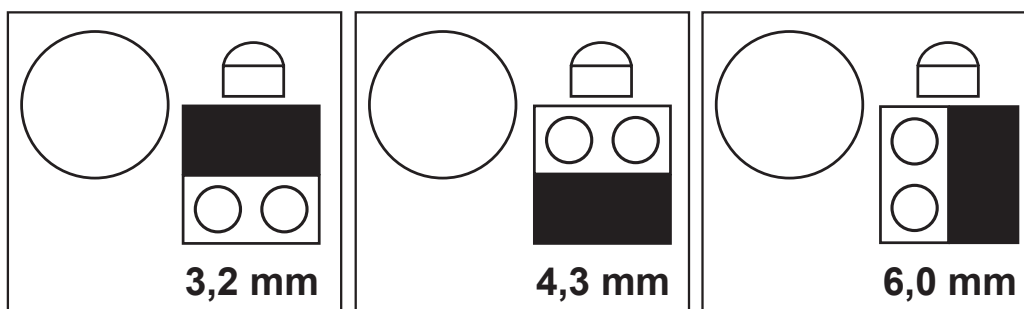

Dimensions (mm)

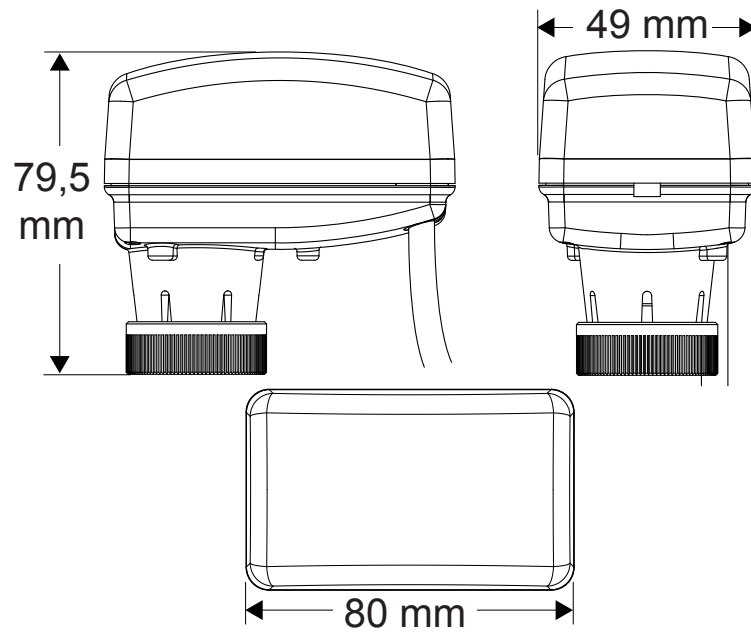

Technical specifications

Actuator models	MF-7480-0001	MF-7482-1001
Action control	Floating or PAT	Proportional
Supply voltage (50/60Hz)	24VAC +/-15%	24VAC +/-15% 24VDC +/-15%
Input impedance		
- Voltage	---	>100 kΩ
- Current	---	500 Ω
Power consumption		
- Apparent	2.5 VA	2.5 VA
- Active	1.5 W	1.5 W
Nominal force	120 N +30% -20%	
Maximum mechanical stroke	6.3mm	
Running time	13 sec/mm	8 sec/mm
Protection	IP43	
Material		
- Cover	ABS + PC	
- Yoke	PA66 – Glass mineral filled (30% total)	
- Thread Nut	Brass CuZn40Pb2	
Housing colour	White semitransparent	
Thread nut connection	See ordering code	
Ambient operating condition	0 °C to 50 °C, non condensing	
Ambient storage condition	-20 °C to 65 °C, non condensing	
Max. fluid temperature	95 °C	
Electrical connections	1.5m cable length (3 x 0.35mm ²)	1.5m cable length (3 x 0.35mm ²)
Operating status indications	LED	
Audible noise rating	< 30 dB(A)	
Shipping weight	0.2 Kg	



Compliance

Pettinaroli UK, declares that this product is in compliance with the essential requirements and other relevant provisions of the EMC Directive 2004/108/EC and Low Voltage Directive 2006/95/EC.