



Technical Submission

Project	Pettinaroli Standard Product - 0X4BxRxxx0		
Version	1.4	Issue Date	03/03/21
Type of Product	Xterminator X4B series compact terminal valve assembly with 40mm centre to centre by-pass and EVOPICCV short stroke PICCV installed in the return with Venturi flow measuring station in the flow.		
Prepared By	Paul Woodley, Anthony Copson		

Pettinaroli UK Ltd

Riverside
Austin Way
Hamstead Industrial Estate
Birmingham
B42 1DU

Telephone	0121 358 2012
Web	www.pettinaroliuk.com
email	solutions@pettinaroliuk.com

This technical submittal contains information that to the best of our knowledge correct at the time of publishing. Pettinaroli UK reserves the right to change the specification of our assemblies at any time. Errors and omissions excepted.

Document Index

Index Item	Page
Design and Selection	
Introduction	3
Function	3-4
Configurations	
Left and Right-Handed	4
Horizontal	5
Additional 4 Port valves	5
Actuator Position	6
Selection	6-7
Flow Rate Control	7-8
Temperature Control	8
Authority	8
Additional Options	8
Labelling and Identification	
Tags	9
Venturi Colour Code	10
PICCV Body Marking	10
Testing	10
Drawings	11
Performance Charts	
Dynamic Flow Data	12-15
Flow Measurement Chart	16
Control Valve Characteristic	17
Installation and Operating Instructions	
Installation	18
Flushing and Isolation	
Media Quality	19
Mains Flush	20
Forward flush and filling	20
Back Fill to Drain	21
Normal Operation	21
Setting and commissioning	22
Pre-setting	22
Setting to a flow rate	22-23
Flow and Differential Pressure Measurement	23
Differential Pressure across the Terminal unit	24
Differential Pressure across the EVOICCV valve	24
Maintenance	24-25
Replacement of FCU coil unit	25
Replacement Parts	25
Venturi	25
Control Valve	25
Individual Components	
EVOICCV	26-27
Venturi Flow Measurement	28
Flushing By-pass	29-30
Coil Connection Tee	30-31
Blow Down Valve	31
Union Connections	32
4 Port Valve	32

Actuation	
Actuator Selection	33
Actuator Fitting	33
Motorised Actuators	33
Thermic Actuators – EVOPICCV	34
Thermic Actuators – 4 Port Valve	34
Self-Acting Actuators	34
Removing Black Protection Handle	35
Actuator Details	
0-10v Proportional (Configurable)	35
Control input	36
Stroke direction	36
Stroke length	36
Calibration Cycle	36
End of stroke confirmation	36
Replaceable Cable	36
24v 3 Point Motorised	36
Control input	36
End of stroke Confirmation	37
Controller Strategy	37
24v or 230v Thermic On/Off	38
First-Open Function	38
Function Indicator	38
Hysteresis	38
0-10v Proportional Thermic	39
Calibration	39
Stand-by operation	39
First-Open Function	39
Function Indicator	40
Hysteresis	40
Fitting Kits	
Fitting Kit Selection	40
Copper Capillary Solder	41
Copper Compression	42
$\frac{3}{4}$ " Flat Face	42
Male BSP Screwed	43
Female BSP Screwed	43
Propriety Fittings	44
Other Fittings	44
Free Issuing Xterminators to a Terminal Unit Manufacturer	
	44

Design and Selection

Introduction

The Xterminator range of terminal valve assemblies is designed to include all of the required valves for controlling and maintaining a Fan Coil Unit or other hydronic terminal unit. All of these functions are offered in a package that is designed to be installed by the terminal unit manufacturer over an extended condensate drip tray.

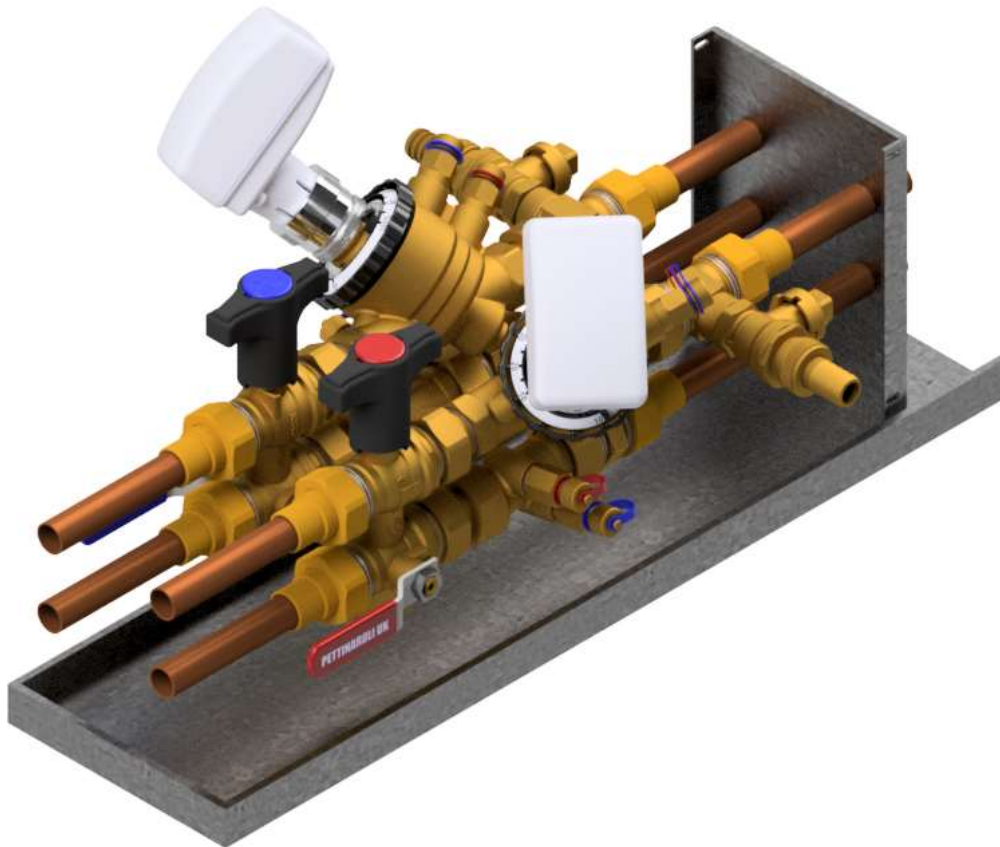

A Pair of Xterminator OX4BXRxxx0 mounted above an extended fan coil drip tray.

Function

The Xterminator includes an EVOPICCV axial pressure independent characterised control valve to maintain design flow rates and provide modulating temperature control; a venturi flow measurement device is included for flow verification purposes. The valve set includes isolation on both the flow and return legs. A flushing by-pass and blow down valve are offered so that the valve set and connected terminal unit may be flushed out of circuit and subsequently Forward flushed to flush the coil. Back flushing through the valve is to be avoided as damage to the valve internal components may occur.

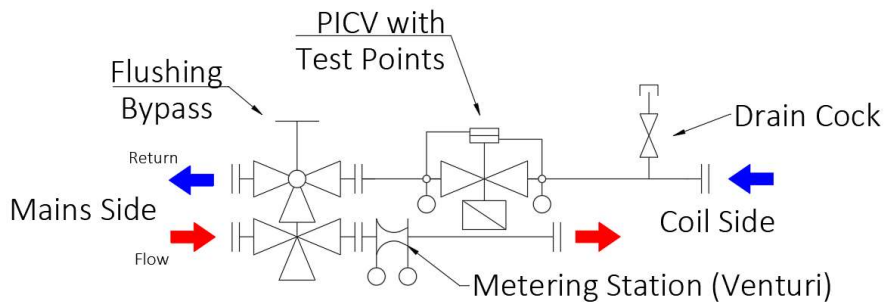

Schematic representation of OX4BxRxxx0

Please contact Pettinaroli UK if you would like schematic drawings or model files in a suitable CAD format. Drawings are available as .DWG (flat 2d or schematic), .STP (3D assembly model) or .RFA (BIM format suitable for Revit).

The valve assembly is offered in three main configurations to suit most fan coil unit designs and is offered with a wide range of end connections.

Configurations

Left and Right-Handed

For fan coil units where the coil is mounted perpendicularly to the floor plate then typically left and right-handed units will be required. The following drawings show how these units are configured.

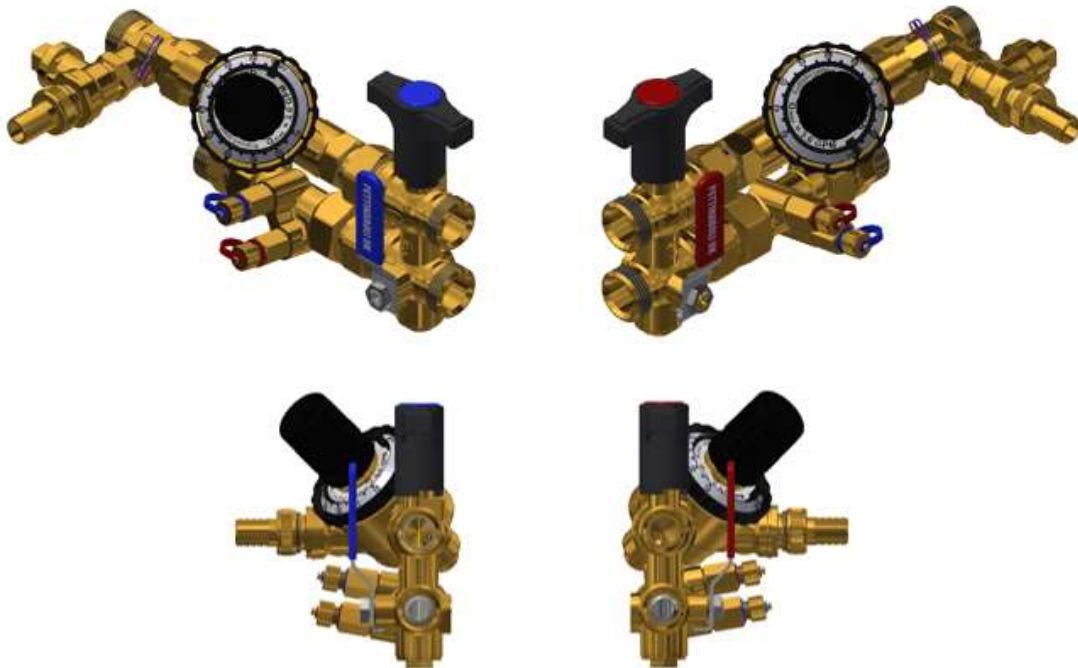

Physical configurations. From Left to right - OX4BxRCLx0 (Left-Handed), OX4BxRHRx0 (Right-Handed).

Horizontal

For Fan Coil units where the coil is mounted either in a parallel orientation to the floor plate or at 45° to the floor plate the Horizontal configuration is the most appropriate. The following drawings show how these units are configured.



OX4BxRCHx0 - Horizontal Configuration Example

Additional 4 Port valves

The OX4 can also be fitted with additional 4 port valves should the need arise please contact Pettinaroli UK for more information.

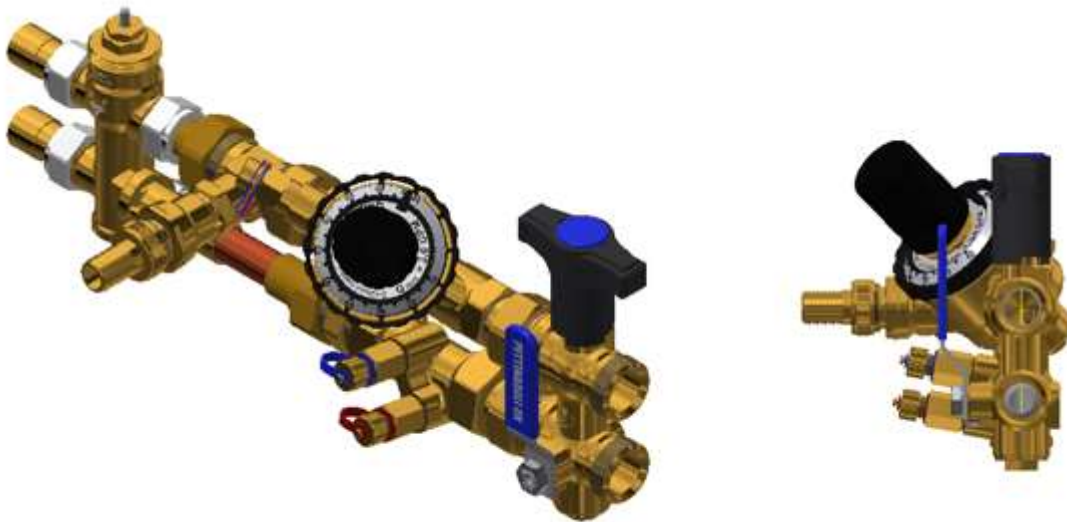

OX4BxRCLx0 (Left-Handed) unit with additional 4 port valve attached .

Actuator Position

To prevent damage to the actuator after installation from condensation, the PICCV should not be installed with the “pin” facing down. Any condensation that forms on the pipework will gather inside the actuator as this will be the lowest point, see below illustration.

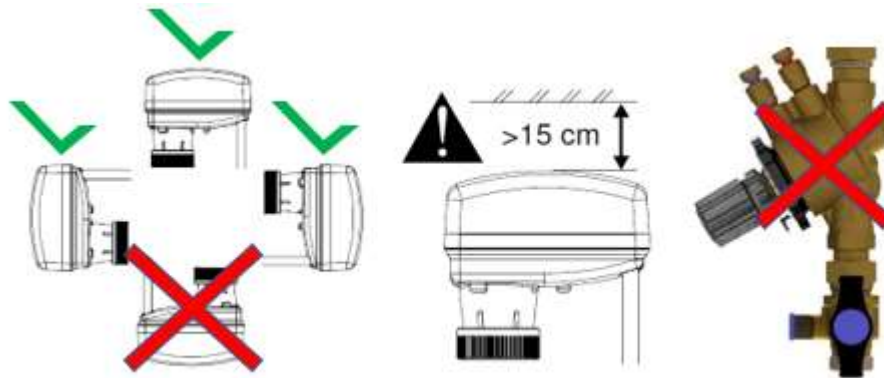

Selection

Selection is performed on design flow rate. There are several variations of the EVOVICV and 6 variations of venturi; the selection table shows the valve and venturi selections based on flow rate.

Due to the fact that the pressure independent characterised control valve, controls the flow rate, irrespective of fluctuations in available differential pressure or the head loss of the coil, the only factor that needs to be considered other than flow rate is that there is enough differential pressure to meet the start-up pressure of the valve.

Base Code	PICCV Size	PICCV Type	Selection flow rates		Venturi size [mm]	Kvs	PICCV Min ΔP	Assy' Min ΔP
			Min	Max				
0X4B1RxxA0	1/2"	VL	0.0	0.032	3	0.37	20	(20) 25
0X4B2RxxB0	1/2"	L	0.0	0.063	4.25	0.72	25	(20) 28
0X4B2RxxC0	1/2"	L	0.0	0.121	6	1.38	25	(30) 40
0X4B3RxxD0	1/2"	H	0.1	0.192	7.5	2.28	30	(40) 40
0X4B4RxxE0	3/4"	L	0.1	0.249	9	3.37	30	(40) 40
0X4B5RxxF0	3/4"	H	0.2	0.377	10.5	4.70	30	(40) 50

The X's in the part number indicate that further selection can be made, for configuration and service, however this does not affect the selection parameters.

Selection flow rate indicates the minimum and maximum range of design flow rates that under normal conditions (at design time) the Xterminator is selected to serve.

The extended range flow rates indicate the maximum range of design flow rates that the Xterminator can be used to control and measure, even if it is not usually selected to serve these flow rates. This can be used to determine if a valve set needs to be modified should the design flow rate change post installation. Flows in this extended range may generate signal pressure losses across the venturi of between 0.5kPa and 15kPa

PICCV Min ΔP is the minimum differential pressure required to provide pressure independent flow control for each PICCV selection, where the PICCV is 100% open. This value reduces as the valve is regulated.

Assembly Min ΔP is the pressure loss through the Xterminator with the PICCV valve set to provide the maximum extended range flow rate and allowing for the minimum differential pressure requirement of the PICCV to be met. This value can be used during pump selection. The value in brackets is the total pressure loss at the selection flow rate.

Flow Rate Control

Due to the internal pressure regulator the differential pressure across the seats (P2 –P3 in the diagram below) in the EVOICCV is always constant. As flow rate is proportional to the product of differential pressure and area of passage, holding the differential pressure constant means that flow rate is only determined by the area of passage. The design flow rate is set using the black hand-wheel on the EVOICCV valve. Moving this handwheel reduces the area of passage through the pre-setting seat of the EVOICCV valve.

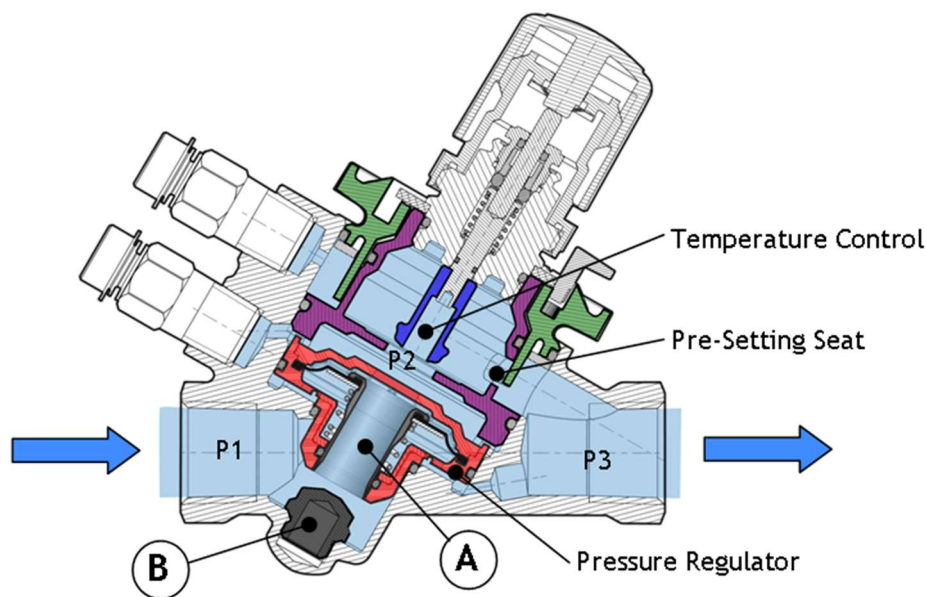

Cross Sectional view of the EVOICCV

The handwheel is graduated in percentage of the maximum flow through the valve. Upon receipt of the required design flow rates Pettinaroli UK will return a schedule of valve selections along with the pre-set positions.

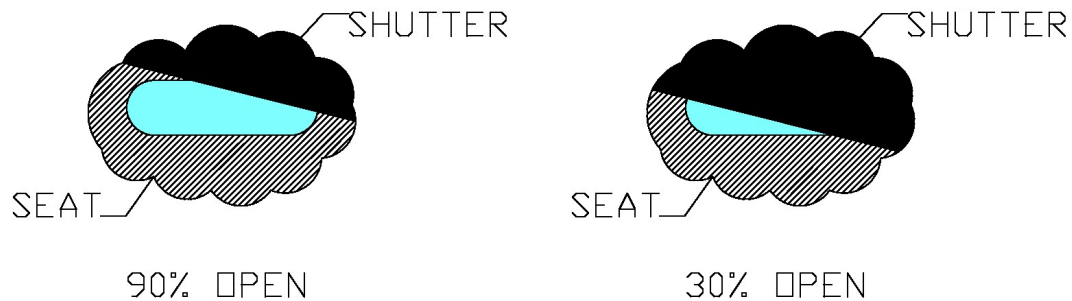

Indication of how the Pre-Setting Seat Operates

Temperature Control

The EVOPICCV also includes an oblique type of globe valve for temperature control purposes. This globe valve is capable of being controlled by a wide range of actuators, including TRV actuators, thermo-electric actuators, and motorised actuators.

Authority

The authority (n) of a valve can be calculated from the pressure drop across that valve compared with the local system. In this case written as

$$n = \frac{P_a}{P_a + P_b}$$

In the case of a pressure independent characterised control valve the differential pressure across the control valve is controlled to the same value regardless of whether the valve is fully open, closed or at part load. This means that a pressure independent characterised control valve has an authority of 1.

For more information on designing PICCV systems please see Pettinaroli UK' Definitive guide to Pressure Independent Characterised Control Valves.

Additional Options

The 0X4BxRxxx0 valve assembly is designed as a value engineered standardised unit, that will cover 90% of our customers' requirements with one standard valve assembly. However, should you require additional features (Such Additional test points, Air Vent, Additional Drains etc) Please Contact Pettinaroli UK To discuss options.

Strainers

The 0X4BxRxxx0 does not include its own integral strainer within the assembly, as such to help protect the assemblies from impurities in the systems media (*more information to be found on page 17*), It may be prudent to consider the installation of a large bore strainer such as a "Pettinaroli

Filterball” be fitted to the beginning of each section branch pipework and at transitions between clean pipework systems (such as copper, press-fit steel and plastic) and black iron pipework.

If a strainer is required for each Terminal unit then a Y-type strainer can be included within an assembly. However, this would be a different product from OX4B range which has a Y-strainer integral to it (I.e. OX4BxRxxxS). *Please contact Pettinaroli UK for more information.*

Labelling and Identification

As standard each Xterminator is tagged and labelled in such a way that it is uniquely intended for a particular terminal unit. The labelling is also intended to make the flow and selection criteria clear when to technician is working on it.

Tags

Each Xterminator is labelled with a valve tag similar to the one below; this will contain the following information.

- 1) Project reference – Pettinaroli UK internal number
- 2) Schedule issue level
- 3) Valve Reference, as defined by customer
- 4) Xterminator Product Code
- 5) Design Flow Rate
- 6) Control / Balancing Valve Part Number
- 7) Maximum unit flow rate
- 8) The Valve Setting, Based on Design Flow Rate
- 9) Balancing valve setting
- 10) Venturi size selection
- 11) Venturi Kvs

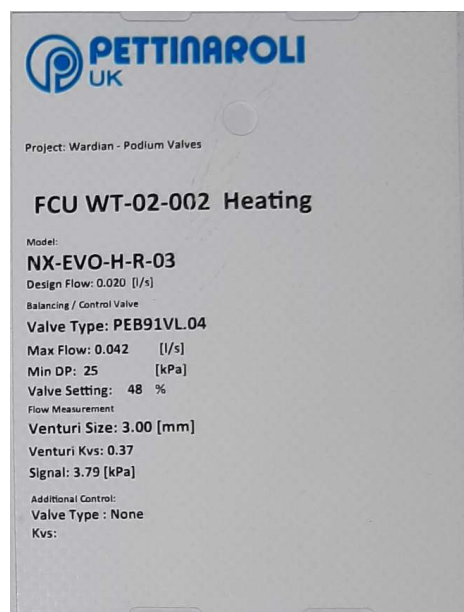

Example of Pettinaroli Identification tag

Venturi Colour Code

The venturi inserts fitted will be identified by a coloured cable tie that attaches the above tag to the valve set. This is in addition to the valve tag and body mark. This all gives a quick guide to venturi insert and control valve selection.

Venturi Size	Colour
3mm	White
4.25mm	Green
6mm	Orange
7.5mm	Blue
9mm	Yellow
10.5mm	Red

PICCV Body Marking

If all other markings have been removed, the size of PICCV fitted can be identified by the markings on the setting hand wheel and chrome disk on the head work.

Valve Type	Part Code on Hand Wheel	Chrome Disc Marking	Venturi Size
PEB91VL.04	91VL ½" 150 l/hr	150 l/hr	3mm
PEB91L.04	91 L ½" 600 l/hr	600 l/hr	4.25mm or 6mm
PEB91H.04	91 H ½" 780 l/hr	780 l/hr	7.5mm
PEB91L.06	91 L ¾" 1000 l/hr	1000 l/hr	9mm
PEB91H.06	91 H ¾" 1500 l/hr	1500 l/hr	10.5mm

Testing

Each valve set is leak tested by means of air pressure under water, a test pressure of 7 bar is used with a test period of 3 minute.

On successful completion of this test the Xterminator is labelled with the valve tag. The test results including test pressure and serial number are logged and traceable.

Drawings

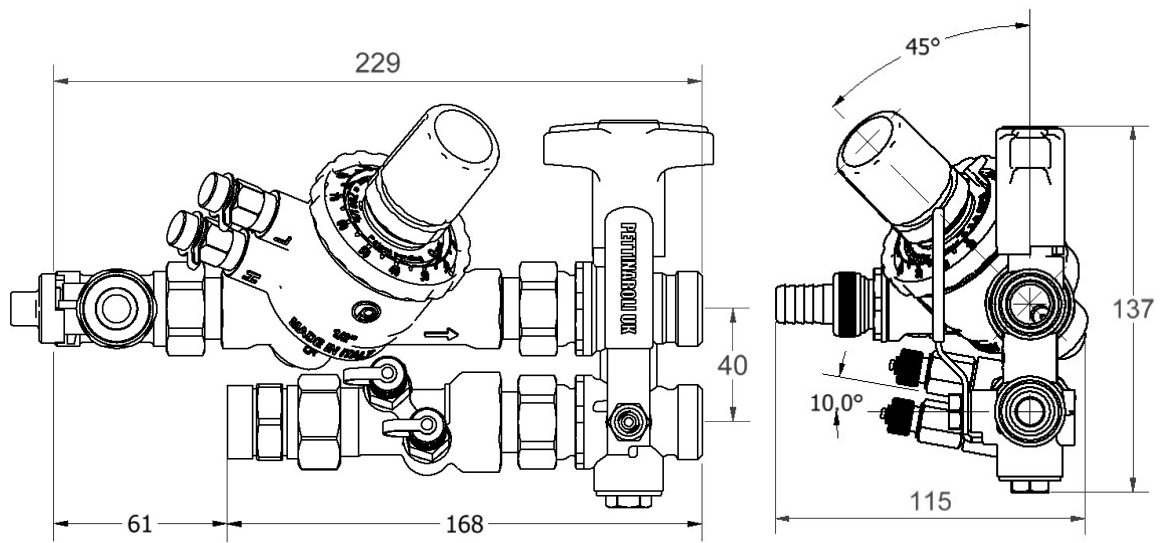

OX4BxRxLx0 (Example of 1/2" Variant shown above)

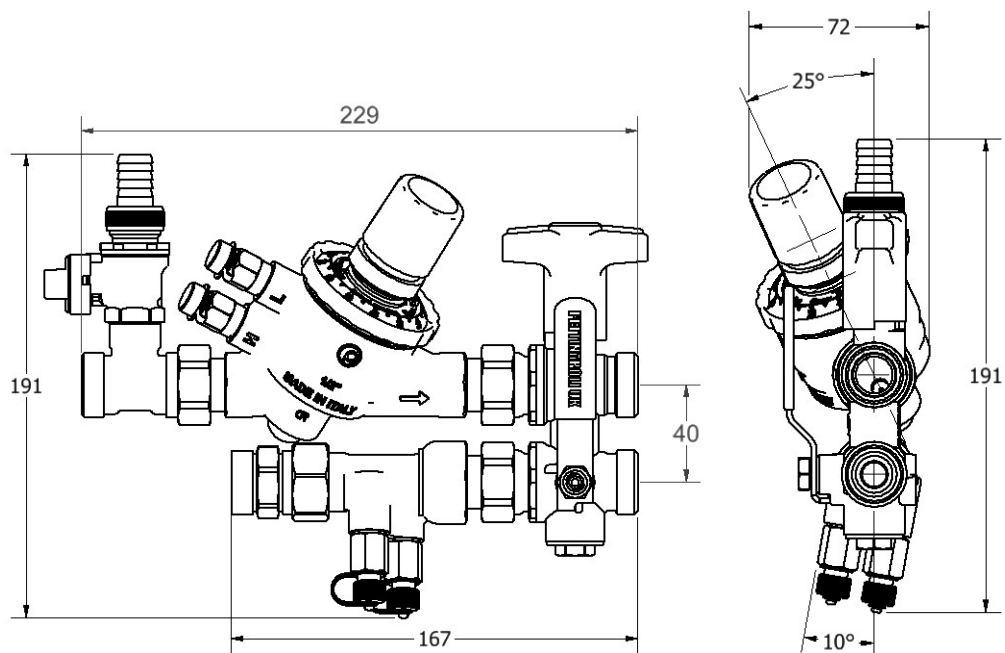

OX4BxRxHx0 (Example of 1/2" Variant shown above)

Data

Characteristic	
Pressure Rating	PN10
Flow Rate Range	0.013 – 0.42 l/s Dependent on Valve Selection
Working Temperature Range	0 – 100°
Working Differential Pressure Range	25 – 400kPa Minimum Depends on Valve and Setting. The working differential pressure can be extended to 600kPa but 400kPa is recommended to avoid unwanted noise
Flow Control Accuracy (Linearity and Hysteresis)	±10% Across working DP range
Control Valve Characteristic	Equal Percentage
Control Valve Leakage Rate to IEC 60534-4	Class IV
KV - Flushing Bypass (Bypass Mode)	2.1
KV – Flushing Drain	5

Performance Charts

Dynamic Flow Data

The dynamic flow charts presented below indicate the flow response in l/s for a particular valve setting with varying differential pressure. This allows the performance of the valve to be evaluated and the start-up pressure (the differential at which the valve starts to control the flow rate) to be observed. The charts below show the pressure loss across the entire Xterminator assembly; measurements were taken at the inlet and outlet connection.

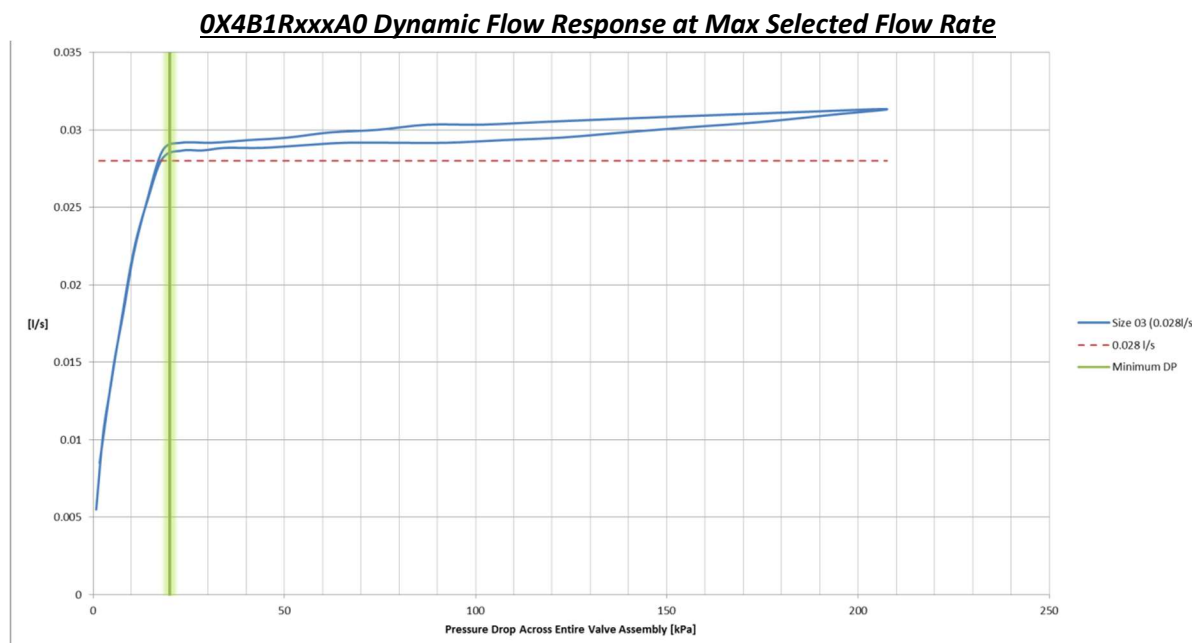

OX4B2RxxxB0 Dynamic Flow Response at Max Selected Flow Rate

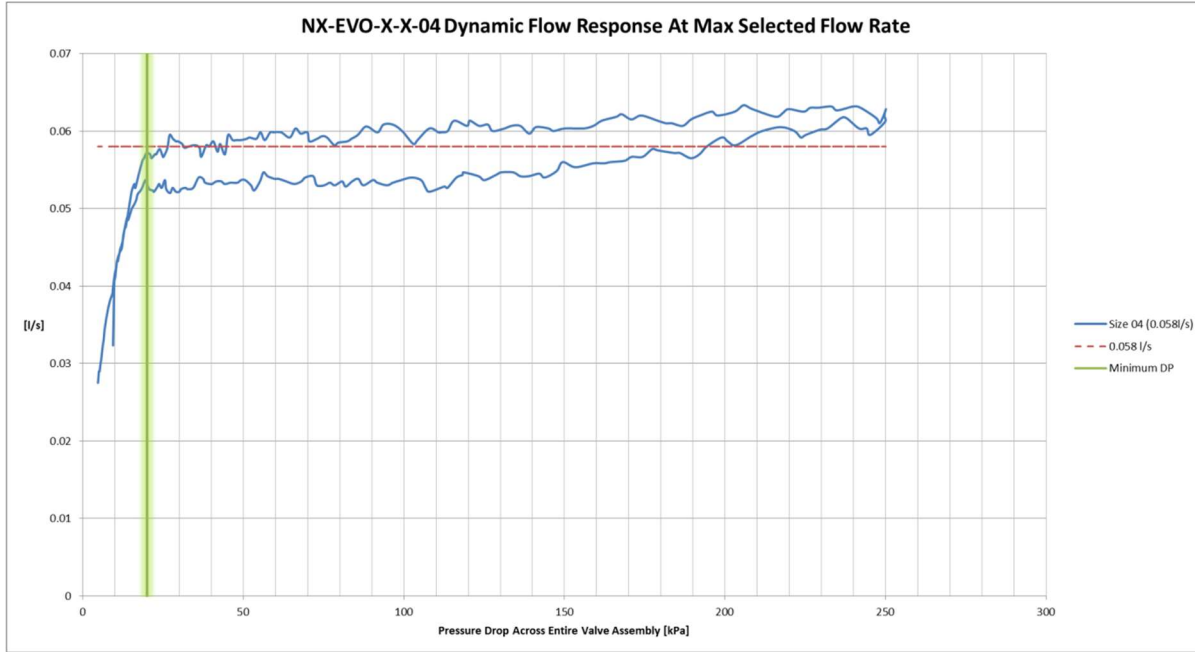

OX4B2RxxxC0 Dynamic Flow Response at Max Selected Flow Rate

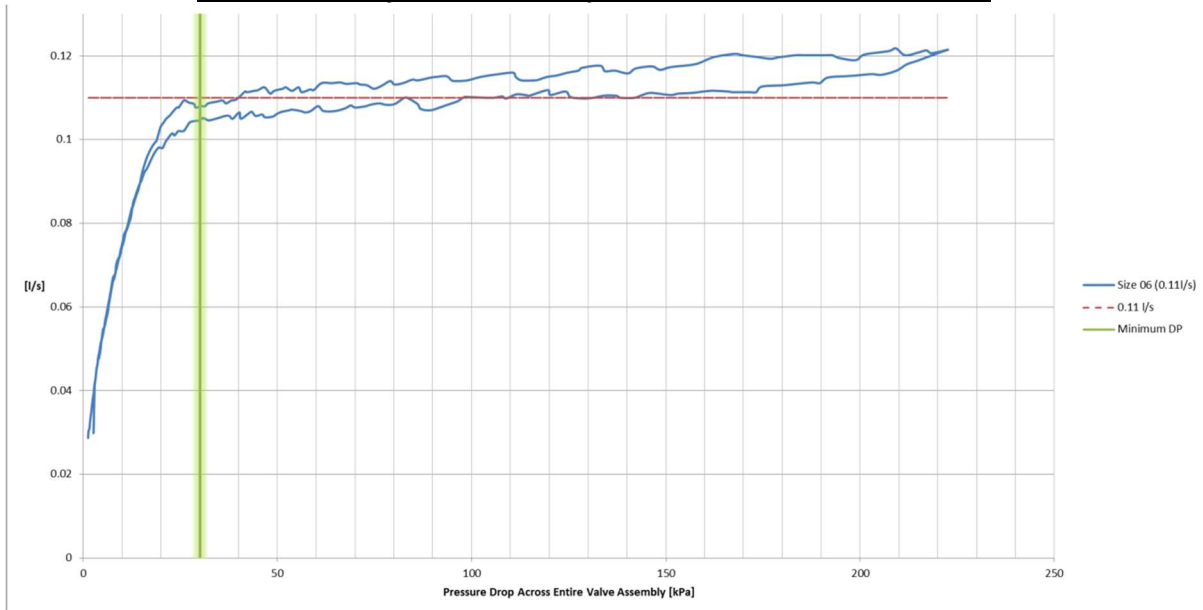

OX4B3RxxxD0 Dynamic Flow Response at Max Selected Flow Rate

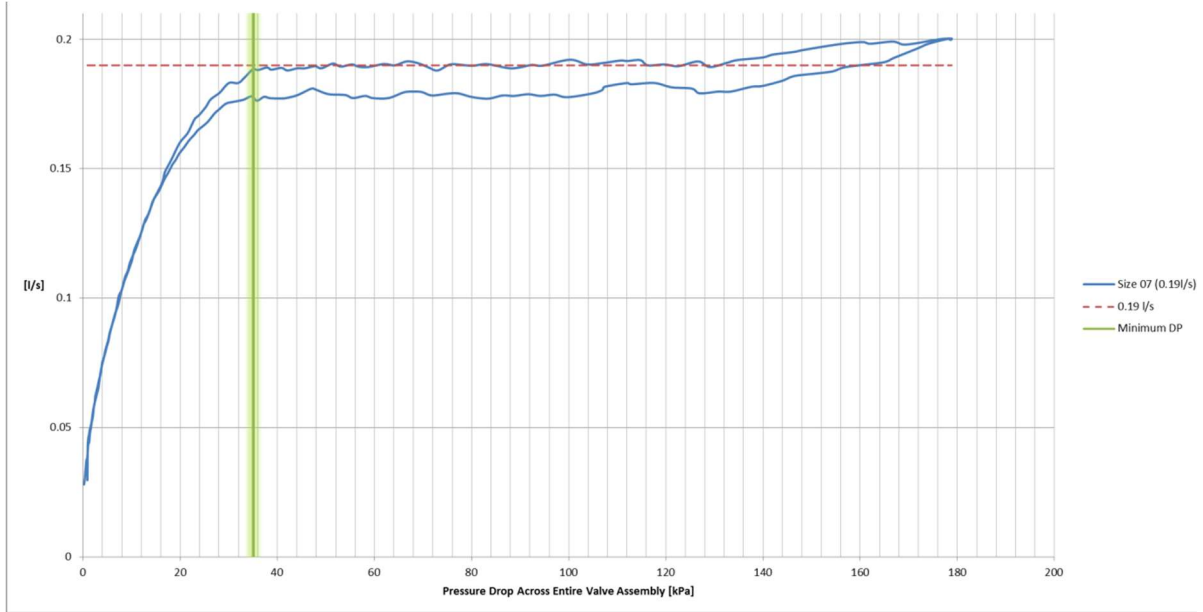

OX4B4RxxxE0 Dynamic Flow Response at Max Selected Flow Rate

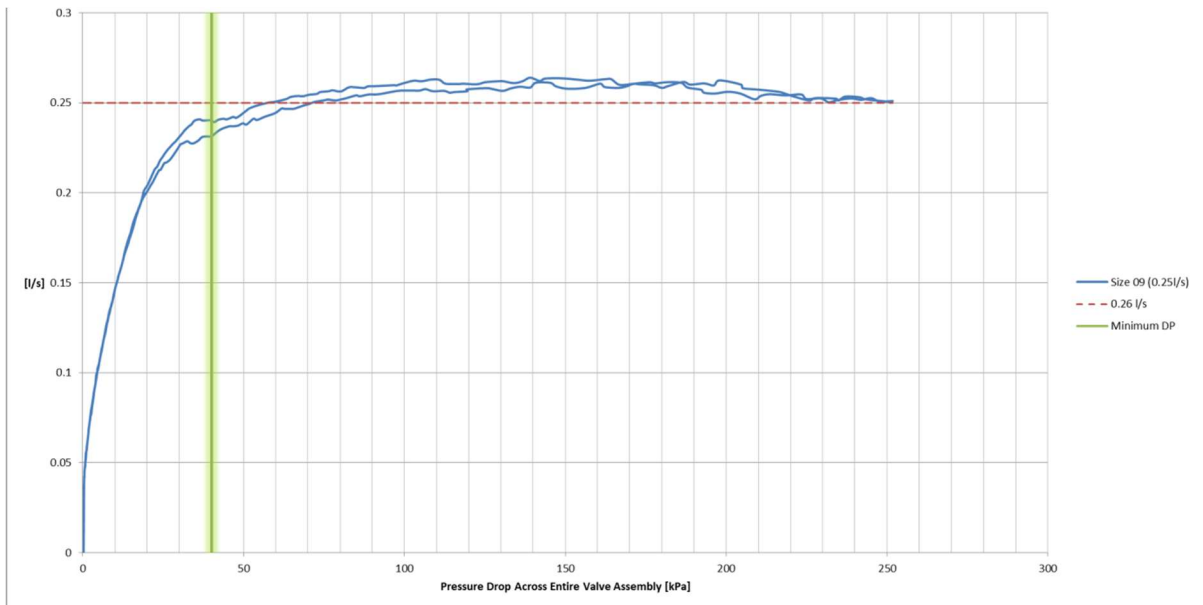

OX4B5RxxxF0 Dynamic Flow Response at Max Selected Flow Rate

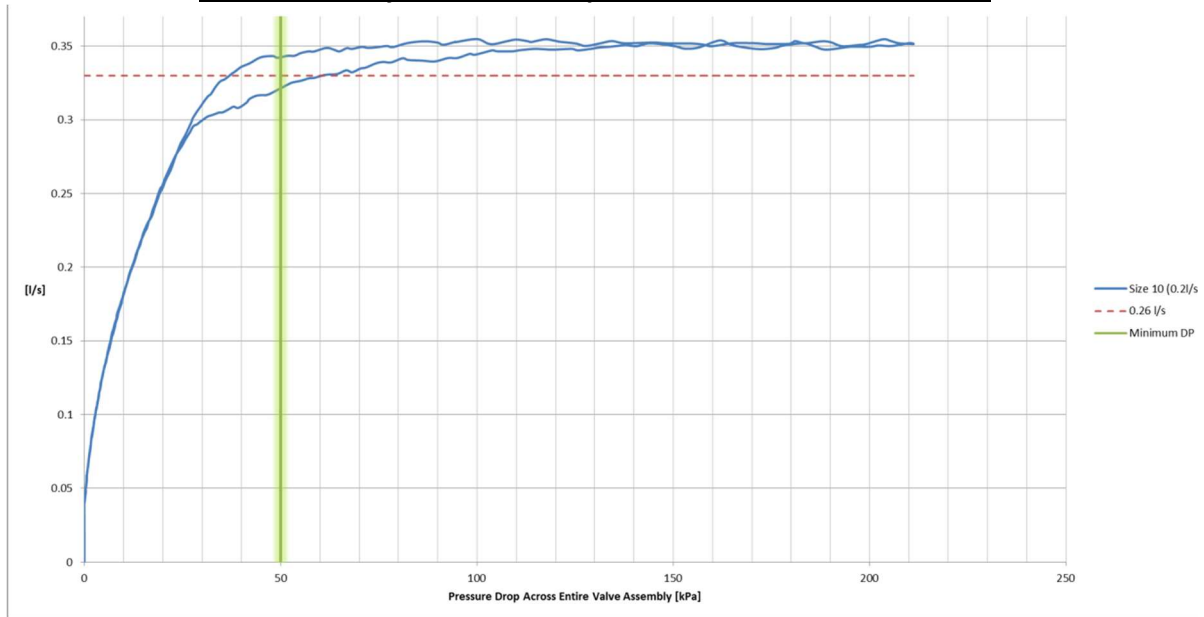

Flow Measurement Chart

The below chart plots the Kvs of the various venturi inserts when installed in the complete valve assembly. The selection boundaries are also shown on the chart, the green bars show the typical range of flow rates that each venturi can be selected to measure (between 2 and 10 kPa). The red bars show the maximum useful range of the venturi, readings beneath 0.5kPa will not be as accurate, and above 15kPa the intrinsic pressure loss of the venturi will be too high.

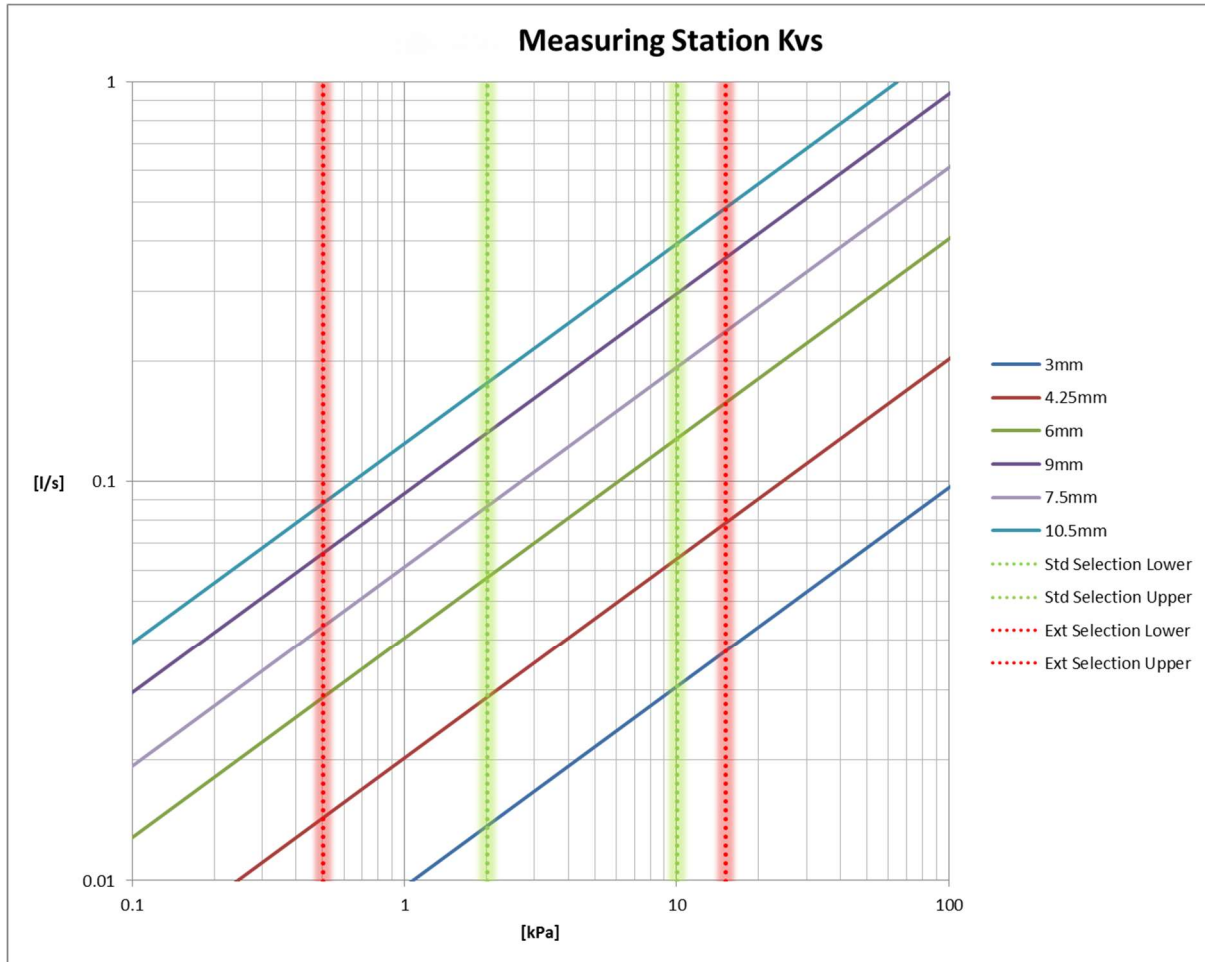

Control Valve Characteristic

The plot below shows the normalised control valve characteristic when the Xterminator is fitted with the two most common actuator combinations. The EA-M-PR is a 0-10v proportional actuator and the EA-M-3P is a 3-point floating type.

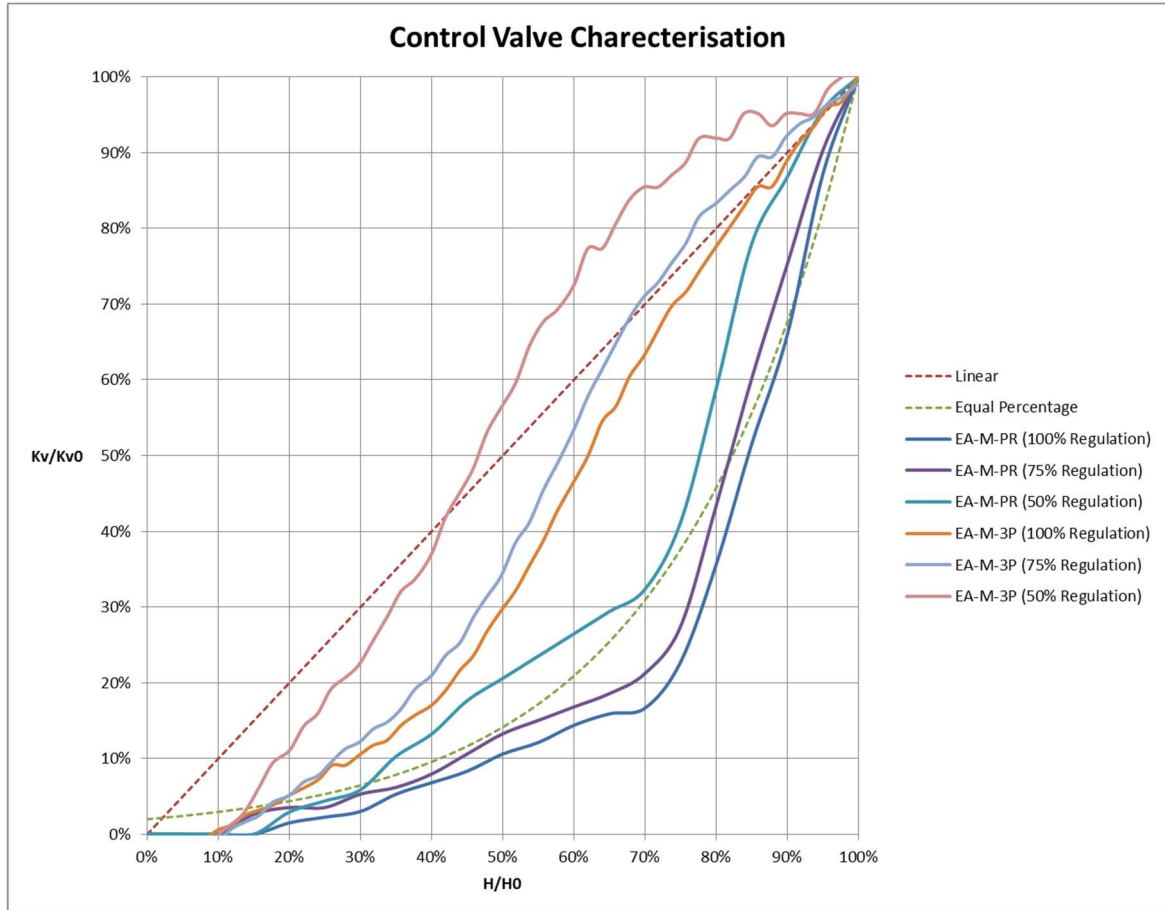

Installation and Operating Instructions

Installation

Care should be taken when screwing pipe adaptors to the valve set not to over stress the joints, avoiding, where possible, mixing tapered and parallel threads on the same joint. We would also recommend that a liquid pipe sealant or PTFE tape is used in preference to hemp and other fillers.

Our union connectors incorporate hexagon flats for use with non-serrated jawed tools; never use Stilsons or other serrated jawed tools to tighten these or any other brass fittings.

All union nuts in the standard Xterminator are 30mm across flats; nuts connecting onto the 4-port fitting kit are 24mm across flats. We would recommend the use of a modified flare nut spanner (as detailed below) or a crows foot spanner. Please observe the stated torque requirements when tightening union joints and compression fittings (*See Fitting Kit specifications elsewhere in the document for information on individual recommend torques for each recommended union*).



30mm Flare Nut Spanner, Modified with 30mm Slot

Always remove any O-rings from solder fittings before applying heat, do not solder union connections in place.

When connecting end fittings to the Xterminator ensure that any Torque applied is properly countered so that other connections are not loosened.

When opening and closing the drain valve use a short spanner of the correct size (12mm), using a spanner of excessive length or grips can damage the internal stops of the valve.

The Xterminator should be properly bracketed to the terminal unit drip dray; the design and construction of the mounting system and ensuring that the drip tray is of sufficient size will be the responsibility of the terminal unit manufacturer. There is an M6 tapped blind hole on the bottom of the flushing by-pass valve intended to facilitate easy and secure bracketing of the valve assembly.

Care should be taken to avoid galvanic corrosion where there is metal on metal contact.

Flushing and Isolation

Media Quality

We would expect that the system to which the Xterminator is fitted be pre-cleaned and flushed in accordance to the standards and principles detailed in the BSRIA guide “Pre commission cleaning of pipework systems” (BG29/2020) and the water quality maintained to standards as detailed in BSRIA guide “Water treatment for closed water systems” (BG50/2013).

The valves used in the Xterminator contain a number of O-Rings, washers and seats made variously of NBR, EPDM, PTFE and Viton, please ensure compatibility of these materials with any water treatments, chemical cleaning agents and other compounds exposed to the media such as pipe sealants. PICCV's may be damaged by very high levels of suspended solids (particularly Iron Oxide and other corrosion products), it is critical that levels of suspended solids in the system are kept to a minimum in line with BSRIA guide BG29/2020. A Y type strainer within the unit is not a substitute for suitable water treatment.

The Xterminator is intended for use with group 2 non-aggressive liquids only.

The valve set is configured such that it can be easily flushed out of circuit (by-passed) and to allow the back flushing of the connected coil (however please note this process does not go through the PICCV). The Valve set only be forward flushed to fill and purge the valve with treated water.

- a) So as not to flush dirt through the EVOPICCV valve
- b) The EVOPICCV valve is a flow limiting valve, by forward flushing through this valve the media velocity may not achieve those needed for an adequate flush.

In general, the flushing procedure should be as follows: -

- 1) Mains flush.
- 2) Forward flush and filling.
- 3) Back fill to drain.
- 4) Normal Operation.

After flushing, water quality should be maintained in accordance with best practice.

Mains Flush

To perform a mains flush: -

- 1) Isolate the return leg using the isolation valve.
- 2) Open the flushing by-pass valve, so that the handle is perpendicular to the axis of the by-pass inlets, this also isolates the flow leg.

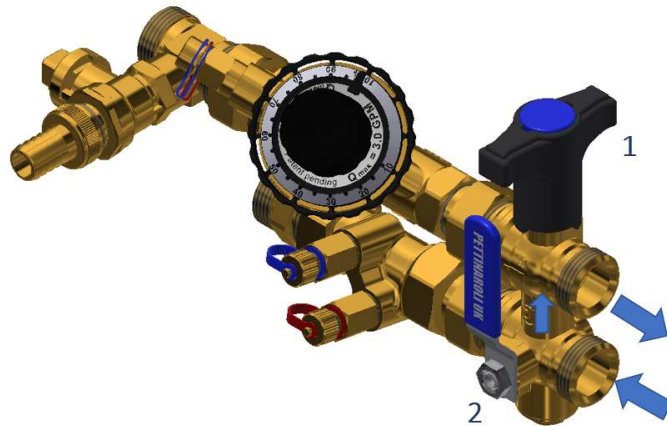

Forward flush and filling

To perform a forward flush: -

- 1) Isolate the return leg using the isolation valve.
- 2) Close the flushing by-pass valve, so that the handle is parallel to the axis of the by-pass inlets.
- 3) Close the EVOICCV valve.
- 4) Open the blow down valve to allow a small amount of treated water to be drawn into a bucket thus ensuring the entire valve set is full of the treated water.
- 5) Close the blow down valve and ensure that the cap is replaced.

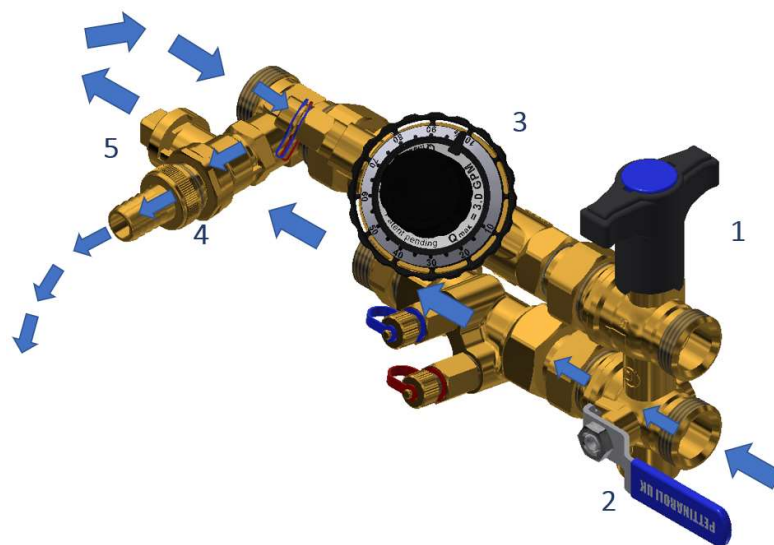

Back Fill to Drain – Short time recommended (max. 5sec)

The valve set can be backfilled to drain in order to purge and flush the attached valve.

- 1) Open the EVOPICCV either using the knob provided or by driving the actuator closed.
- 2) Open the flushing by-pass valve, so that the handle is perpendicular to the axis of the by-pass inlets. It should still be in this position from the mains flush.
- 3) Open the return isolation valve slightly to allow a small flow through it.
- 4) After attaching a hose to blow down valve using the supplied hose barb, open the blow down valve for short time only (max. 5sec.) to allow a small amount of water through, enough to fill the valve and clear the section of air.

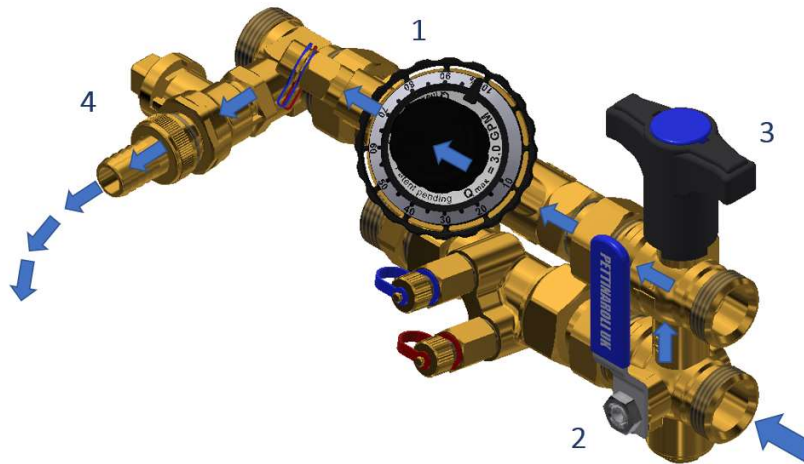

Be sure to isolate and cap off the blow down valve before returning the valve set to service.

It should be noted that the manufacturers do not recommend back flushing through the PICCV as damage may occur to the internal components of the valve.

Normal Operation

The valve set should be configured as follows during normal operation.

- 1) Return isolation valve is open.
- 2) The flushing by-pass valve is closed, so that the handle is parallel with the axis of the valve inlets.
- 3) Any override clutches on the EVOPICCV actuator are disengaged; the valve will be positioned as determined by the BMS controller.

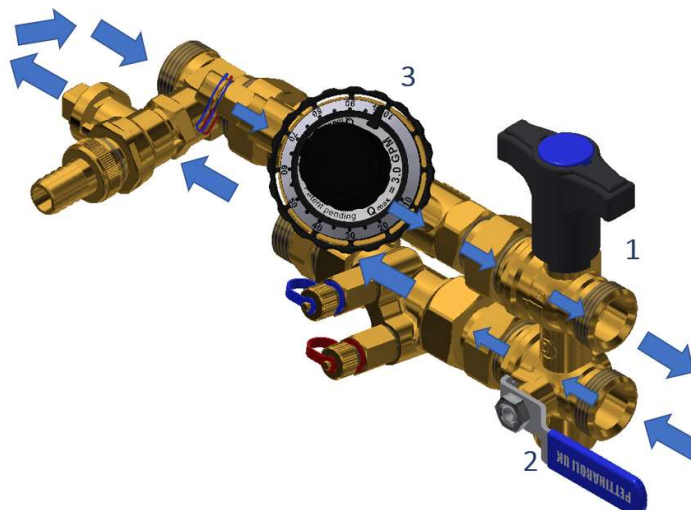

Setting and commissioning

For more information on commissioning PICCV systems please see Pettinaroli UK's Definitive Guide to Pressure Independent characterised Control Valves.

The Flow rate can be set by adjusting the black hand-wheel on the EVOICCV to the required position. The set position is expressed as a percentage of the EVOICCV valve's maximum flow rate and is calculated by dividing the design flow by the maximum nominal flow of the valve and multiplying by 100.

$$\text{Setting} = \frac{\text{Design Flow Rate}}{\text{Valve Maximum Flow Rate}}$$

For example where the design flow rate is 0.1 l/s and the valves maximum flow rate is 0.166 there are two main approaches to commissioning the valve assembly.

$$\text{Setting} = \frac{0.1}{0.166} = 0.60 = 60\%$$

Pre-setting

With the valve set in the normal operating mode the EVOICCV can then be pre-set to the calculated position as detailed on the selection schedule; the flow rate can then be measured later using the venturi.

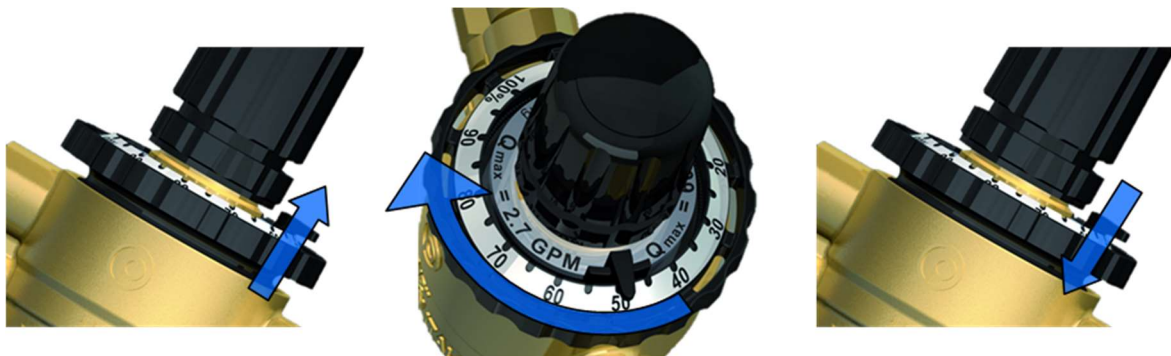

Lift the lock pin to unlock the hand-wheel. The hand-wheel is graduated from 100% to 10%, turn the hand-wheel to the calculated percentage as indicated by the lock pin. Press the lock pin to lock the hand-wheel in position.

When the valve is pre-set there will be a wider variation in measured results compared to if the valve was set to a flow rate using the venturi flow measurement device.

Before setting the valve ensure that the black protection handle is removed and that the actuators are fitted that they have been driven fully open.

Setting to a flow rate

With the manometer connected to the flow measurement station the pre-setting wheel can be adjusted until the correct differential pressure measurement is achieved.

The set position should be recorded on the commissioning documentation along with the manometer readings and flow rate. Deviations of more than 15% from the calculated set position

should be cause for investigation as they may indicate problems with the local installation or the PICCV.

Before setting the valve ensure that the black protection handle is removed and if the actuators are fitted that they have been driven fully open.

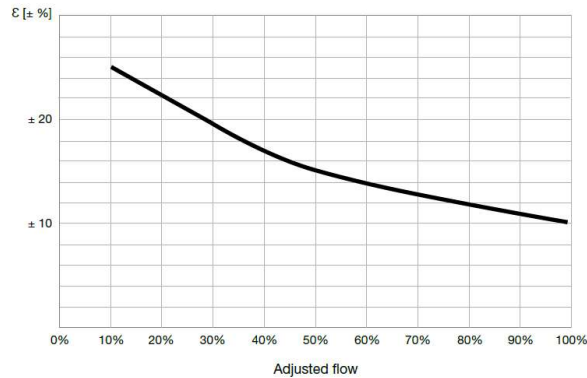

Setting Accuracy vs Hand Wheel Position (PET Have different Chart)

Flow and Differential Pressure Measurements

The Xterminator valve assembly comes equipped with multiple pressure temperature readout ports. These are all of the binder type and allow for the following measurements to be taken:

- Flow Rate through the terminal unit
- Differential pressure or temperature across terminal unit
- Differential pressure across EVOICCV valve
- Static pressure or temperature at the terminal unit

To measure the flow rate passing through the terminal unit

Connect the measurement instrument (U-tube manometer or electronic manometer) to the venturi flow measurement device, being sure to purge the pressure lines. Use the stated Kvs to calculate the flow rate based on the differential pressure reading taken and the following formula: -

$$Q = \frac{\sqrt{\Delta P} \times Kvs}{36}$$

Where:

Q = Volume Flow rate in l/s

Kvs = Valve factor as stated on the valve tag or schedule

ΔP = Differential pressure measurement in kPa

Differential Pressure across the Terminal unit

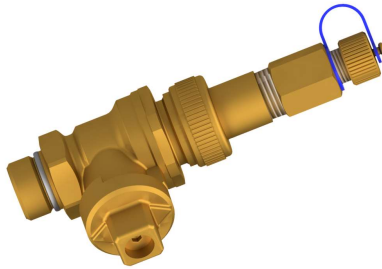

Pettinaroli UK also offers an optional test point adaptor that be used on its flushing drains. This enables pressure reading to be taken from drain points, thus removing the need for additional test points. This can be used to enable readings to be taken across the coil of the terminal unit. Please contact Pettinaroli UK for further information if required.

Differential Pressure across the EVOPICCV valve

If the EVOPICCV has both of its test points fitted then simply connect the measuring instrument to these test points. The high and the low side are indicated by the letters H and L in the body forging.

If only a single pressure tapping is fitted this will be fitted to the high-pressure port; connect the high-pressure side of the measuring instrument to this port. The low-pressure tapping can be taken from the blow down valve using an adaptor available from Pettinaroli UK (part number TP.DQ.04).

Please note that flow rate cannot be measured across the EVOPICCV valve, if a flow rate is required always use the venturi.

Maintenance

The valve set is maintenance free as far as regular service requirements however, the valve assembly can facilitate some maintenance activities.

If there are any specific requirements e.g. for the end fittings these will be detailed on supplementary sheets.

It should be noted that when in the closed position, the flushing by-pass valve still allows water to by-pass through the connecting loop. Leaving the valve in this position is not recommended when a system has been balanced and is in service as it will provide uncontrolled water way and potentially affect the balance of the system.

If a particular coil is to be taken out of service for an extended period of time then the valve set should be isolated using a return isolation valve only.

Alternatively, it is possible to fully isolate the terminal legs of the by-pass by removing the handles when the valves are in the closed position. The balls may then be manually rotated 180°.

Although the flushing by-pass valve will also isolate the flow leg it will simultaneously open the by-pass which may mean that the by-pass circuit itself becomes the most favoured loop on a circuit. This could result in the entire floor being put out of balance.

Xterminator units that share a common heat exchanger with a live heating system should not be double isolated (flow and return) without draining down.

Replacement of FCU coil unit

The valve set comes complete with 2 unions at the coil end. These unions allow the coil unit to be removed whilst leaving the valve set in situ to isolate the pipework. To dismantle these unions please ensure.

- 1) That the return leg isolation valve is closed and that the by-pass valve is opened isolating the flow leg.
- 2) The EVOPICCV valve is closed, either by the BMS controller or by means of the override clutch on the actuator.
- 3) The unions require a 30mm spanner (24mm spanner if a DN10 4 port fitting Kit is used)
- 4) Replace the coil as per the manufacturer's instructions.
- 5) If the coil connection blocks and O-rings are serviceable after they have been dismantled then they may be replaced onto the new coil unit, otherwise contact Pettinaroli UK for replacements.

Replacement Parts

All parts in the Xterminator can be field replaced; a ½" control valve may be exchanged for a ¾" one and vice versa. Care must be taken if the control valve is exchanged for another variant that the matching venturi is also installed.

Venturi

The venturi can be replaced in the field; for convenience the entire venturi housing and insert along with the inlet union tail will be replaced as a unit. To replace the venturi

- 1) Isolate flow and return isolation valves
- 2) The EVOPICCV valve is closed, either by the BMS controller or by means of the override clutch on the actuator
- 3) Use blow down valve to de-pressurise and drain the terminal
- 4) The union nuts require a 30mm spanner, a modified flare nut or crows foot spanner is recommended
- 5) Loosen the front and back union nut on the return leg
- 6) Remove old venturi housing
- 7) Install new venturi housing by following the instructions in reverse

Control Valve

The EVOPICCV control valve can be replaced in the field, for convenience the control valve and union tails will be replaced as a unit. To replace the control valve

- 1) Isolate flow and return isolation valves
- 2) Use blow down valve to de-pressurise and drain the terminal
- 3) The union nuts require a 30mm spanner, a modified flare nut or crows foot spanner is recommended

- 4) Loosen the front and back union nut on the return leg.
- 5) Remove old control valve.
- 6) Install new control valve by following the instructions in reverse.

Individual Components

EVOPICCV

For more information on how PICCVs operate, please see Pettinaroli UK's Definitive Guide to Pressure Independent Characterised Control Valves.

One of the problems associated with 2 port control is sizing and making sure all of the control valves have adequate authority. Whilst this problem is helped by the use of differential pressure controllers it can still be difficult to maintain good authorities without specifying that each terminal unit requires a DPCV. Using traditional valves this would be a very expensive design approach.

The pressure independent characterised control valve (PICCV) combines the functions of a differential pressure controller, regulation valve and 2 port control valves into a single body.

The EVOPICCV incorporates a small diaphragm type DPCV in order to keep a constant differential pressure across an orifice and to provide a constant flow rate whilst the differential pressure is within the operating limits of the valve. Beyond these working pressures the valve acts as a fixed orifice.



EVOPICCV valve

Making this orifice adjustable allows the valve to be pre-set to deliver a range of flow rates. In the case of the EVOPICCV valve this adjustment can be made in situ without removing any covers or actuators, the adjustment wheel is lockable by means of a combined memory stop and indicator.

The EVOPICCV valve also includes 2 port temperature control by means of an oblique pattern globe valve. The plug of the globe valve is machined to give a near equi-percentage flow control characteristic. Due to the fact that the differential pressure across the valve seat is constant it can be said that the authority of this control valve is very close to 1.

The EVOPICCV can be fitted with a range of actuators including thermo-electric ON/OFF and modulating actuators, TRV sensors and motorised actuators.

When shut tight, the globe valve is a metal on metal seal and as such the leakage rate should be no more than 0.01% of the nominal maximum flow of the valve as defined by class IV of IEC60534-4.

Due to the way the EVOPICCV valve controls the flow rate, irrespective of differential pressure branch and sub mains, balancing valves are not required. The flow rate is maintained at the terminal unit regardless of system conditions making the valve ideal for systems with inverter driven pumps.

Component	Material
Body	DZR Brass CW602N OR Brass CW617N (EN 12165)
Headwork	Brass CW614N (EN 12165)
Cartridge Sleeve	Stainless Steel
Diaphragm	High resistance EPDM
O-Rings	EPDM
Adjustment Ring	PSU

Characteristic	
Pressure Rating	PN25
Flow Rate Range	0.013 – 0.42 l/s Dependent on Valve Selection
Working Differential Pressure Range	25 – 400kPa Minimum Depends on Valve and Setting, valve will operate up to 600kPa, 400kPa is recommended to avoid unwanted noise
Accuracy (Linearity and Hysteresis)	±10% Across working DP range
Temperature Range	0 – 100°
Leakage Rate to IEC 60534-4	Class IV

Venturi Flow Measurement

The Terminator Interchangeable venturi housing is based on the proven venturi inserts used in our Terminator commissioning valve. The same venturi inserts are used but we have recalculated the Kvs values in situ in an entire Xterminator valve set close coupled to a typical fan coil, this means that each venturi is calibrated for the exact situation in which it is used.

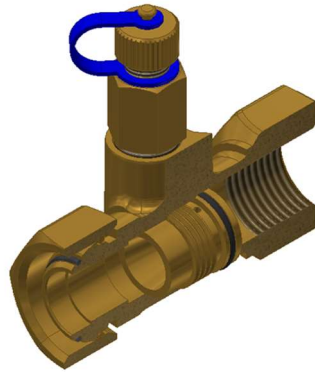

Terminator Interchangeable Venturi Flow Measurement Device

Sizing of the venturi is usually carried out to give differential pressure readings between 2 and 10kPa as this is the most accurate range of the venturi but also allows digital manometers to be used.

The venturi allows high signals of up to 15kPa to be achieved without significant residual pressure loss.

The Terminator interchangeable venturi housing is machined from a hot forged DZR Brass body.

Component	Material
Body	DZR Brass CW602N (EN 12165)
Venturi Insert	Brass CW614N (EN 12164)
Test Point	Brass CW614N (EN 12164)
Test Point Core	Ethylene Propylene Rubber EPDM
O-Rings	EPDM
Nut	Brass CW617N (EN 12164)

Characteristic	
Pressure Rating	PN25
Working Differential Pressure Range	1.5 – 15kPa
Accuracy (Linearity)	±5% Across working DP range
Temperature Range	0 – 100°

Flushing By-pass

BSRIA application guide “Pre-Commission cleaning of pipework systems” recommends that all terminal units are fitted with fixed flushing by-passes. This BSRIA guide is referenced in the CIBSE Code W “Water Distribution systems”.

The Pettinaroli UK flushing by-pass valve has been designed specifically with Fan Coils in mind, although it is suitable for all types of hydronic terminal unit.



Flushing Bypass

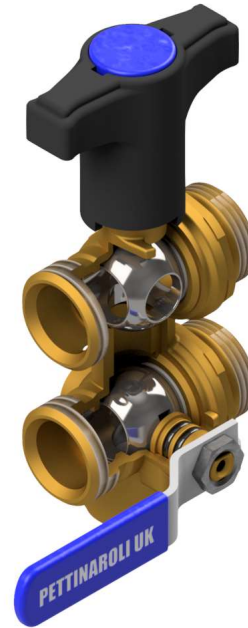

Normal Operation



Mains Flush



Forward Flush

The by-pass valve comprises of two through connections joined by a perpendicular by-pass section. The top connection incorporates a special 4-way ball valve, the bottom through section contains a three ported ball valve which allows for two operation modes - by-pass and flow. These flow sections are arranged at 40mm centres so as to provide a way to directly mount any valve set to a fan coil unit with matching 40mm centre inlet/outlets.

The bottom ball valve has three ports machined in a T configuration. In flow mode, the middle port is sealed against the third and fourth seats preventing water from flowing through the by-pass (Class IV leakage rate as defined by IEC60534-4). As the valve is moved into by-pass mode the outlet side of top flow connection is isolated (Class VI leakage rate as defined by IEC60534-4) whilst the by-pass connection is opened allowing the two inlet connections to be flushed through.

The top ball valve has a special 4 port configuration machined in T plus 1 configuration. The bottom port is always open to the by-pass. In normal operation the main through port allows water to flow between the inlet and outlet; the bottom ball will prevent water communicating through the by-pass unless moved to apposition to let it flow. When the ball is rotated through 90° the main through ports are isolated between the seats and the forth port is opened to the mains outlet, this allows water to flow between the by-pass and the outlet but seals the terminal connection.

Connections are of the euroconus type which allows direct connection to many proprietary piping systems in addition to copper, steel and flexible connections.

Component	Material
Body	DZR Brass CW602N (EN 12165)
Balls	TEA Plated Brass CW617N (EN 12165)
Insert	DZR Brass CW602N (EN 12165)
Seats	PTFE
O-Rings	FKM / EPDM
Stems	BRASS CW614N (EN 12165)

Characteristic	
Pressure Rating	PN25
Temperature Range	0 – 100°

Coil Connection Tee

The coil connection set is intended to provide a simple way of connecting the Xterminator unit to the terminal coil tails. The coil connection tee can be configured with a number of end connections by means of a fitting kit and has ports for a drain and optional accessory such as an air vent or test plug. The final function of the coil connection tee is to provide a union joint at a position where the coil could be removed whilst the bulk of the Xterminator remains connected to the pipework providing isolation.

The coil connection tee is manufactured from forged DZR brass.



Coil Connection Tee with Various Accessories

Component	Material
Body	DZR Brass CW602N (EN 12165)

Characteristic	
Pressure Rating	PN25
Temperature Range	0 – 100°

Blow Down Valve

The blow down valve is of the ball type, the handle is of the square drive type and may be opened and closed using a 12mm square drive or spanner, shut off is positive. The handle is a heavy-duty square drive and may be used to lock the valve closed if the handle is removed and then reinstalled rotated 180°. The connection to the Xterminator is sealed by use of an O-ring. A cap and 14mm hose barb are included.

Component	Material
Body	Brass CW617N (EN 12165)
Ball	NICKEL PLATED BRASS CW617N (EN 12165)
Insert	Brass CW614N (EN 12165)
Seats	PTFE
Stem O-Rings	FKM
Stem	Brass CW614N (EN 12165)
O-Ring	EPDM

Characteristic	
Pressure Rating	PN25
Temperature Range	0 – 100°

Union Connections

Union connections are machined from hot forged brass billets to maintain fixed lengths in the assembly.

Component	Material
Body ½"	Brass CW617N
Body ¾"	Brass CW614N (Annealed)
Nut	Brass CW617N
O-Rings	EPDM

Characteristic	
Pressure Rating	PN25
Temperature Range	0 – 100°

4 Port Valve



4 Port Control Valve

The 4 port valve is supplied with either ½" x 15mm compression ends or ¾" flat face unions depending on the size of the valve selected. The valve has an equal percentage characteristic and uses the same actuators as the EVOPICCV valve. The valves are manufactured from nickel plated brass in nominal DN10 sizes and cast gun metal in nominal sizes DN15 and larger.

Component	Material
Body	CW617 Brass CuZn40Pb2 (EN12165)
Plug and Stuffing Box	EPDM
Stem	AISI 303 stainless steel (X10CrNiS1809)
Spring	AISI 302 stainless steel (X10CrNi1809)

Characteristic	
Pressure Rating	PN16
Temperature Range	0 – 100°

Actuation

Actuator Selection

The table below shows actuator part numbers for different control types.

Type	Standard	With 4 Port Valve
24v, 0-10v Proportional	EA-M-PR-1-3-1	EA-M-PR-1-4-1
24v, 3 Point Floating	EA-M-3P-1-3-1	EA-M-3P-1-3-1
230v, 3 Point floating	EA-M-3P-2-3-1	EA-M-3P-2-3-1
24v, 0-10v Proportional Thermic	EA-T-PR-1-4-1	JCVA-7098-21
24v, ON-OFF Thermic	EA-T-OO-1-4-1	JCVA-7078-21
230v, ON-OFF Thermic	EA-T-OO-2-4-1	JCVA-7078-23

Actuator Fitting

Motorised Actuators

To mount the actuator, first fully remove the black isolation cap. The actuator is supplied with a separate actuator mounting ring, this is mounted onto the valve headwork, if desired use a spot of thread locking adhesive to ensure the ring is retained with the valve. Making sure that the actuator is in its fully open position, mount the actuator on the headwork and then tighten the collar nut until it is hand tight. **WARNING! THE ACTUATOR MUST BE FITTED TO THE VALVE BEFORE ANY POWER IS APPLIED TO IT. Damage may occur if the actuator is powered up without being fitted to the valve.**

Prior to removing the actuator, it should be driven fully open before being powered down, this will ensure that it can be properly fitted again; do not try to fit an actuator with the spindle in an extended position.

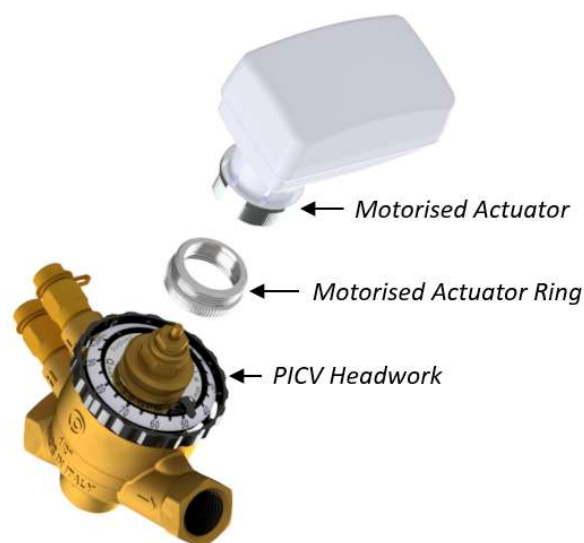

Fitting Motorised Actuator To PICCV

Thermic Actuators – EVOPICCV

To mount the actuator, first fully remove the black isolation cap. The actuator is supplied with a separate actuator mounting ring, this is mounted onto the valve headwork, if desired use a spot of thread locking adhesive to ensure the ring is retained with the valve. To mount the actuator, it is then pushed onto the adapter ring until the clips retain the actuator.

Thermic actuators are supplied in a first open position, this means that they have can be fitted easily. Once the actuators have been powered on, the actuator will be more difficult to fit unless driven open.

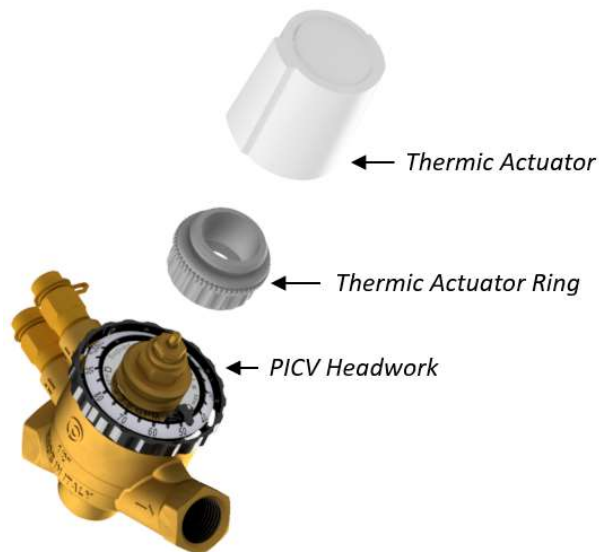

Fitting Thermic Actuator To PICCV

Thermic Actuators – 4 Port Valve

To mount the actuator, first fully remove the blue isolation cap. The actuator is supplied with a separate actuator mounting ring, this is mounted onto the valve headwork, if desired use a spot of thread locking adhesive to ensure the ring is retained with the valve. To mount the actuator, it is then pushed onto the adapter ring and the bayonet fitting is turned by 90° to secure the actuator.

Thermic actuators are supplied in a spring loaded first open position, this means that they have can be fitted easily to a range of different valves, however once the actuator has been removed the actuator must be returned to this position before it can be mounted again. This is accomplished by pushing down the spring-loaded internals of the actuator and then moving the bayonet fitting back to its starting position.

Self Acting Actuators

The self-acting actuators mount directly to the PICCV. First ensure that the black isolation cap is completely removed, then with the self-acting actuator positioned in the fully open position, mount on the headwork and tighten the collar nut.

Removing Black Protection Handle

Do not attempt to fit the actuator if the black handle has not been fully removed. Sometimes the lower portion of the handle is too tight to remove by hand, in this case gently use a pair of grips to remove the handle.



Correct, Handle fully removed



Incorrect, handle partially removed

Actuator Details

WARNING! THE ACTUATOR MUST BE FITTED TO THE VALVE BEFORE ANY POWER IS APPLIED TO IT. Damage may occur if the actuator is powered up without being fitted to the valve!

0-10v Proportional (Configurable)

This is our recommended actuator for the EVOPICCV when fitted to forced convection terminal devices such as fan coils and air handing units. The actuator is a compact unit that is field configurable such that is suitable for a wide range of applications.



0-10v Motorised Actuator

Control input

The actuator can be controlled by a number of different signals, including 0-10v, 2-10v, 0-5v, 5-10v and 4-20mA. The actuator is factory set to 0-10v.

Stroke direction

The stroke direction is factory set to reverse acting, this may be changed in the field if required.

In order to suit the EVOPICCV, the actuator should be set to reverse acting as the EVOPICCV is normally open. This will allow the actuator to work with controllers that are set to direct acting without needing any change to the controls.

Stroke length

In order to adapt the stroke length to different valves, there is a jumper that will change the effective stroke length. This jumper is factory set but can be changed on site if required. Please note that while the actuator will self-calibrate to find the closing position, it works on a fixed stroke basis.

Calibration Cycle

When the power is applied, the actuator self-calibrates performing a complete cycle. The actuator moves the stem down for a complete mechanical valve stroke until no changes are detected. Once the auto-zero is detected the actuator moves the stem accordingly with the input signal.

End of stroke confirmation

When the input signal is at 100% the actuator turns on every 2 hours and drives in the signal direction for approximately 60 seconds to confirm the end of stroke position.

Replaceable Cable

The connection cable is fitted with a plug so that the actuator can be swapped without unwiring the cable from the controller.

24v 3 Point Motorised

This is a 24v 3-point floating actuator for the EVOPICCV, suitable fitted to forced convection terminal devices such as fan coils and air handling units. The actuator is a compact unit that is suitable for several sizes of valve. A 230v version is available for special applications.

Control input

The actuator is controlled on a drive open, drive closed basis.

When the signal is applied to the black and red wires, the actuator stem extends. When the signal is removed the actuator remains in position.

If the signal remains applied to the red wire, the actuator will time out and shut off the motor after approximately 90 seconds.

When the signal is applied to the black and orange wires, the actuator stem retracts. When the signal is removed the actuator remains in position.

If the signal remains applied to the orange wire, the actuator will time out and shut off the motor after approximately 90 seconds.



3 Point Motorised Actuators

End of stroke Confirmation

When the signal is applied in the same direction, the actuator turns on every 2 hours and drives in the signal direction for approximately 90 seconds (13 sec/mm models) to confirm the end of stroke position.

Controller Strategy

The actuator has a maximum stroke of 6mm making it suitable for a number of different valves in our range however, there are a few things that need to be taken account of in the BMS controller strategy.

To ensure the best control characterisation it is vital to match drive time to the valve stroke so that that there is no air gap between the actuator spindle and the valve spindle. The drive time should be calculated by multiplying the stroke length of the valve in mm by the time to drive 1mm.

All 3-point actuators need periodic re-synchronisation to account for positional drift, the re-synchronisation time should be set to 90 seconds in the closing direction of the valve.

24v or 230v Thermic On/Off

This actuator is suitable for passive terminal devices such as radiators and chilled beams, it is cost effective and operates silently.

The actuator mechanism uses a PTC resistor- heated elastic element and a compression spring. The wax element is heated by applying the operating voltage and moves the integrated ram. The force generated by the movement is transferred to the valve stem and thus opens and closes the valve.



Thermic ON/OFF Actuator

The actuator is nominally ON/OFF but can be controlled in a more modulating fashion by pulse pausing the controller output (Pulse Width Modulation). Our standard supply of these actuators is premium version with detachable cable, however on a special-order basis an even more cost-effective version is available with a fixed cable.

First-Open Function

In its delivery condition, the actuator is normally open due to the First-Open function. This enables heating operation during the carcass construction phase even when the electric wiring of the single room control is not yet complete. When commissioning the system at a later date, the First-Open function is automatically unlocked by applying the operating voltage (for more than 6 minutes) and the actuator is fully operable.

Function Indicator

The actuator has a function indicator in the form of a blue band on the actuator stem, this allows identifying the operating condition (valve open or closed) at a glance.

Hysteresis

There is an inherent hysteresis in the operation of any thermic type of actuator, when the actuator has not been used for a period of time there is an extra warm up period whilst the wax is heated up to its working temperature. When the voltage is removed from the actuator there is also cool down period before the actuator will begin to close due to the thermal mass of the wax.

0-10v Proportional Thermic

The 0-10v proportional thermic actuator is offered as an alternative to the motorised proportional actuator.



0-10v Thermic actuator

Calibration

For the variant "normally closed", the valve is opened once by 0.5 mm and then closed again after applying the operating voltage of 24 V AC. For this, the first open function is unlocked and the valve closing point is detected. This ensures an optimum match with the specific valve used.

If a control voltage of 0.5 - 10 V DC is applied after the calibration process, the actuator opens the valve - after the dead time has elapsed with the piston movement, evenly and permanently corresponding to the valve travel. An internal optical path measurement controls the temperature required for the maximum stroke of 4 mm (minus over-elevation) and consequently the energy intake of the wax element. No excess energy is stored inside the wax element. If the control voltage is reduced, the electronic control system immediately adapts the heat input to the wax element. In the range of 0 - 0.5 V, the actuator remains in a quiescent state in order to ignore ripple voltage occurring in long cables. After the waiting time is elapsed, the valve is closed evenly with the closing force of the compression spring.

The closing force of the compression spring is matched to the closing force of commercially available valves and keeps the valve closed when de-energised (NC).

Stand-by operation

The wax element is maintained at stand-by temperature 20 minutes after the control voltage has dropped below 0.5v

First-Open Function

In its delivery condition, the actuator is normally open due to the First-Open function. This enables heating operation during the carcass construction phase even when the electric wiring of the single room control is not yet complete. When commissioning the system at a later date, the First-Open function is automatically unlocked by applying the operating voltage (for more than 6 minutes) and the actuator is fully operable.

Function Indicator

The actuator has a function indicator in the form of a blue band on the actuator stem, this allows identifying the operating condition (valve open or closed) at a glance.

Hysteresis

There is an inherent hysteresis in the operation of any thermic type actuator, when the actuator has not been used for a period of time there is an extra warm up period whilst the wax is heated up to its working temperature. When the voltage is removed from the actuator there is also cool down period before the actuator will begin to close due to the thermal mass of the wax.

Fitting Kits

Various fitting kits are available to adapt the euroconus ends of the Xterminator to different pipe systems. A fitting kit consists of a pair of fittings (flow and return).

Fitting Kit Selection

The matrix below shows the different types and sizes of fitting kits available; the bold ticks indicate a preferentially stocked item.

	NXFK-	10mm	15mm	16mm	18mm	20mm	22mm	26mm	½"	¾"
Copper Compression	CUC	✓	✓		✓					
Copper Press Fit	CUP		✓		✓		✓			
Copper Capillary Solder	CUS		✓				✓			
Female screwed	FSC								✓	✓
Male Screwed	MSC								✓	✓
Flat Union Adapter	FUA									✓

Fitting Selection Matrix

Copper Capillary Solder

Capillary solder fittings are available to suit 15mm and 22mm pipe. Ensure fittings are properly cleaned before soldering and that any O-rings have temporarily removed.



NXFK-CUS-15 Copper capillary solder 15mm



NXFK-CUS-22 Copper capillary solder 22mm

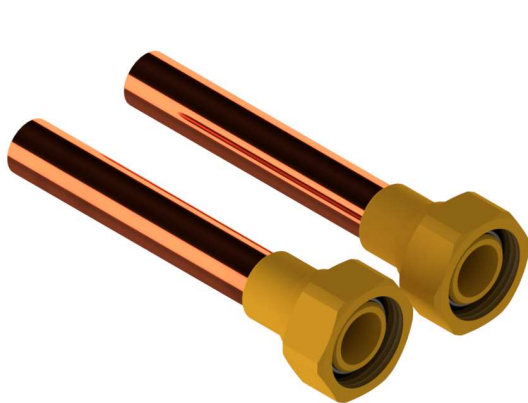

NXFK-CUS-15-100 Copper capillary solder 15mm with 100mm copper length pre-soldered in place

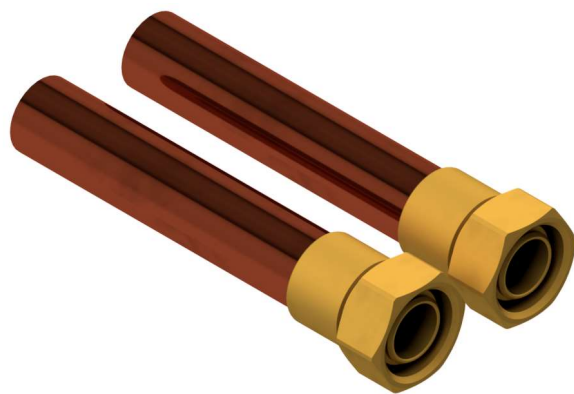

NXFK-CUS-22-P100 Copper capillary solder 22mm with 100mm copper length pre-soldered in place

Characteristic

Pressure Rating	PN25
Temperature Range	0 – 100°
Tightening Torque	30Nm (Pet's Tightening torque is Higher)

Copper Compression

Proprietary copper compression fittings are available in diameters 10mm, 15mm and 18mm. These fittings use an O-Ring and a grip ring to secure and seal the pipe rather than the traditional olive. Fitting instructions are included with the fitting kit; however care must be taken to ensure that maximum tightening torques are not exceeded.

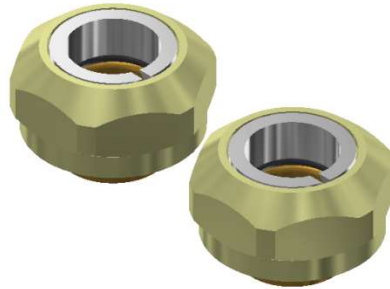

NXFK-CUC-15

Characteristic	
Pressure Rating	PN16
Temperature Range	0 – 100°
Tightening Torque	30Nm (Pet's Tightening torque is Higher)

3/4" Flat Face

Long and short adapters from 3/4" euroconus to 3/4" flat face male are used to facilitate the use of proprietary fittings from other manufacturers. Using these adapters also almost all pipe systems to be accommodated by selecting fittings with a 3/4" swivel nut.



NXFK-FUA-06-S

Characteristic	
Pressure Rating	PN25
Temperature Range	0 – 100°
Tightening Torque	30Nm (Does this need a Tightening torque?)

Male BSP Screwed

Long and short adapters are available in 1/2" and 3/4" male BSP screwed.

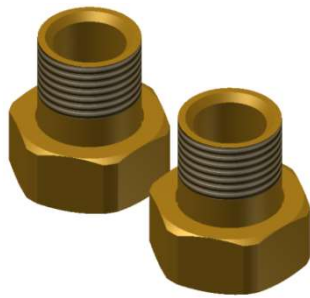

NXFK-MSC-04-S

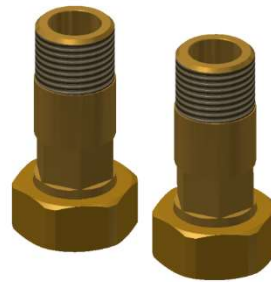

NXFK-MSC-04-L



NXFK-MSC-06-S

Characteristic

Pressure Rating	PN25 (1/2"), PN16 (3/4")
Temperature Range	0 – 100°
Tightening Torque	30Nm (Pet's Tightening torque is Higher)

Female BSP Screwed

Adapters to 1/2" and 3/4" female BSP.



NXFK-FSC-04-SG



NXFK-FSC-06-SG

Characteristic

Pressure Rating	PN25
Temperature Range	0 – 100°
Tightening Torque	30Nm
Pressure Rating	PN10
Temperature Range	0 – 95°
Tightening Torque	30Nm (Pet's Tightening torque is Higher)

Propriety Fittings

Many manufacturers will have proprietary fittings for metal and plastic pipe systems that conform to the Euroconus standard (EN215, Annex A), these should be compatible with the end fittings on the Xterminators.

Other Fittings

Although the Euroconus connection is based on a standard G3/4" thread, its short length and the relief on the back side will make it difficult to affect a seal, as such use of non-union type pipe fittings is not recommended. If you should choose to ignore this advice, please consider using a liquid thread sealant (of adequate strength) rather than traditional pipe jointing methods.

Free Issuing Xterminators to a Terminal Unit Manufacturer

In order to make sure that the project runs smoothly a number of things need to be observed during the order placement process.

- 1) The intended terminal unit manufacturer should be briefed that the coils are required to be delivered to site with the valve sets assembled above an extended drip tray. They should allow a cost for the extended drip tray, brackets and fitting of the free issue valve sets.
- 2) Pettinaroli UK needs to know the appointed Terminal Unit contractor and the name of the responsible person at that manufacturer.
- 3) Please bear in mind that the terminal unit manufacturer will need to receive the valve sets up to 4 weeks before the coils are due on site in order to not to hold them up. Pettinaroli UK needs to have order coverage for the valve sets in advance of this by the lead time advised by our Production Manager.
- 4) If required, Pettinaroli UK will produce samples for supply to the appointed Terminal unit manufacturer such that they can test the fit and configuration of the valve sets with their Terminal unit. If desired, these samples can form part of a site mock-up or test process.
- 5) Pettinaroli UK will require detailed information on unit handing and required connection fitting size before we can commence manufacture.