



Door Air Curtains
UniLine

KAMPMAN
Genau mein Klima.

For “yes-men”

Would you like lower investments? And high-performance?
Then you simply should not deprive your customers of the UniLine.

Step this way!

One step – and your customers are in a pleasant sales environment.
Open doors reduce our reluctance to enter a shop – and besides,
UniLine air screening reduces energy losses.

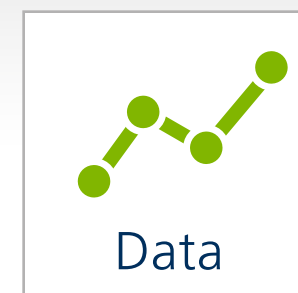
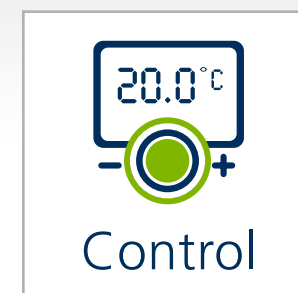
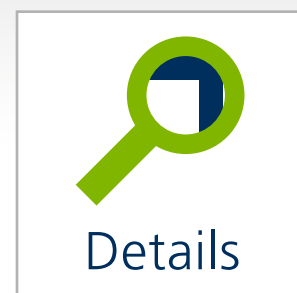
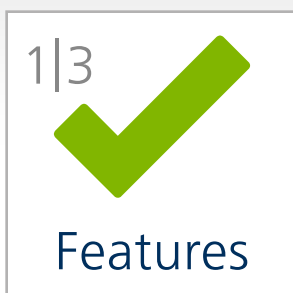

Energy-saving and silent

Silent AutoMotion (SAM) allows high air discharge velocities at low air volumes. The operation in a low mode results in reduced sound emissions. The UniLine features an energy-efficient drive concept through the use of EC technology.

Small shops and large shopping malls

UniLine door air curtains effectively screen doors against cold air. From one to three metres in height, individually or as a wide frontage.

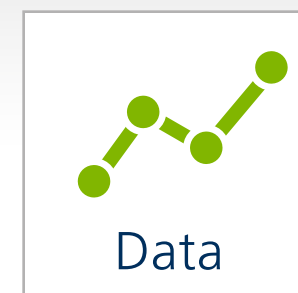
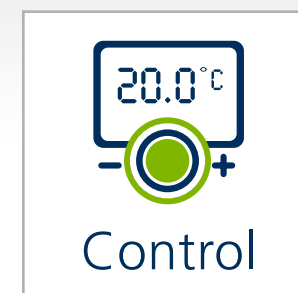
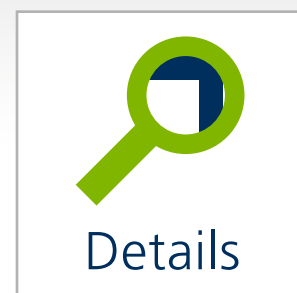
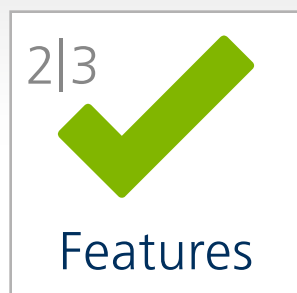

Maintenance-friendly

Make your in-house facilities manager your friend: the large filter, including frame and intake grille, can be removed with ease. The large maintenance access panel is practical. The entire underside of the unit can be opened by a few simple actions.

A reliable choice

UniLine is the door air curtain all-rounder. You can reliably choose the right unit for your project from our streamlined and comprehensive range.

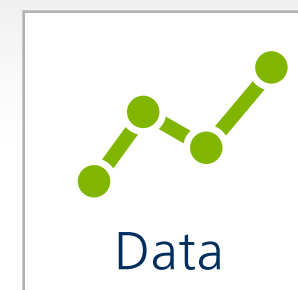
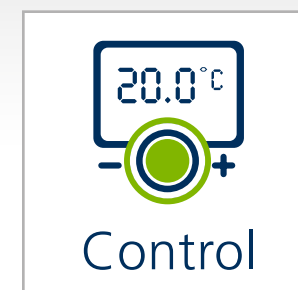
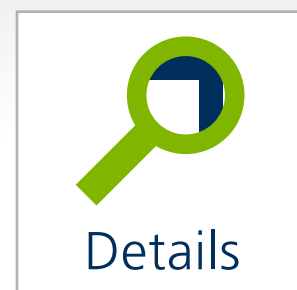
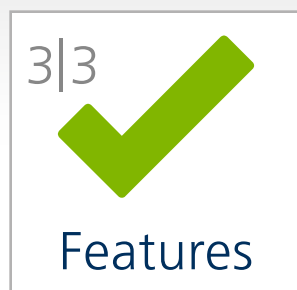

UniLine at a glance

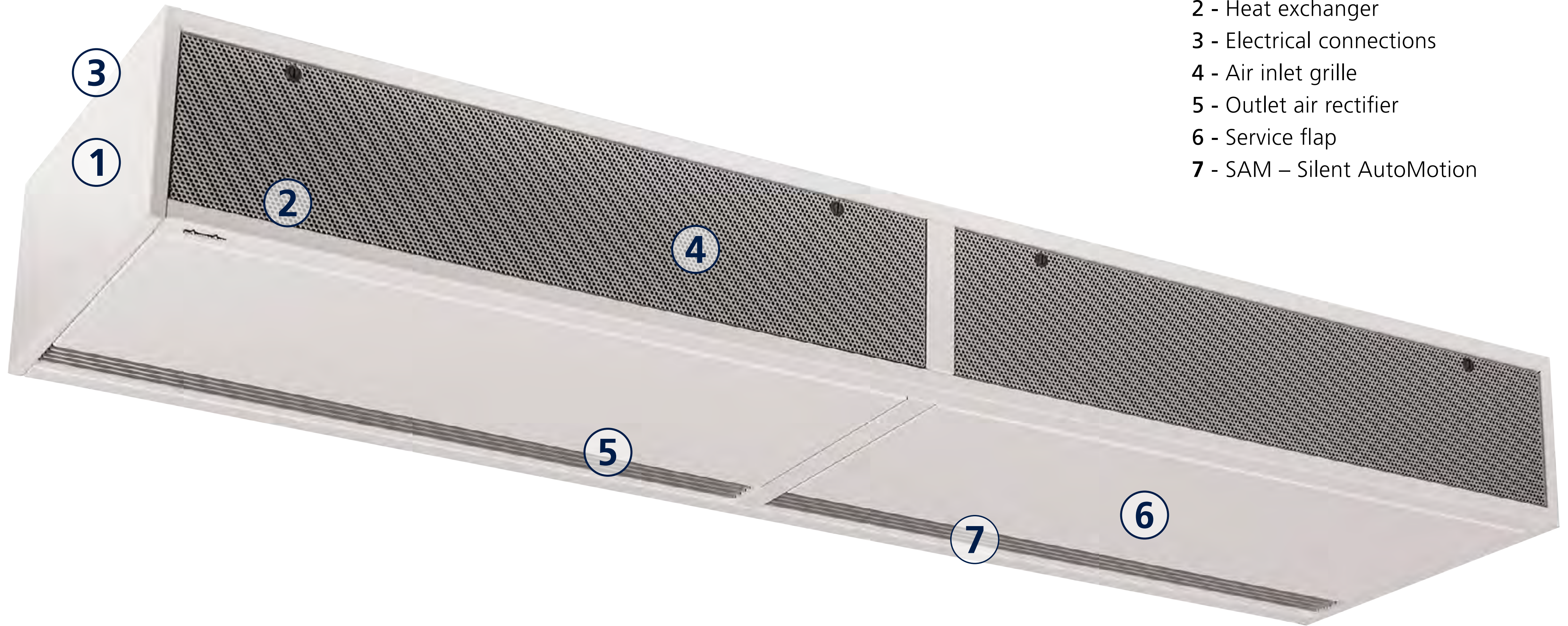

- 1 - Fans
- 2 - Heat exchanger
- 3 - Electrical connections
- 4 - Air inlet grille
- 5 - Outlet air rectifier
- 6 - Service flap
- 7 - SAM – Silent AutoMotion

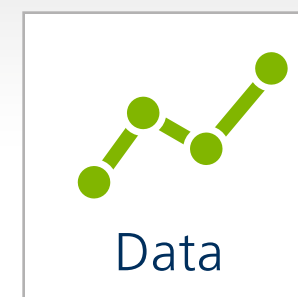
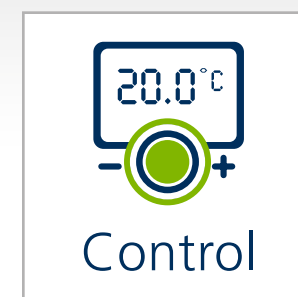
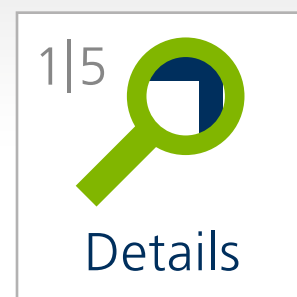
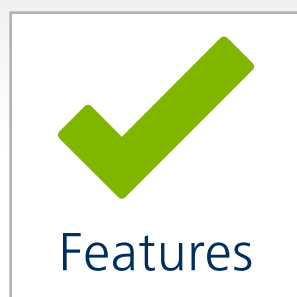

SAM – Silent AutoMotion

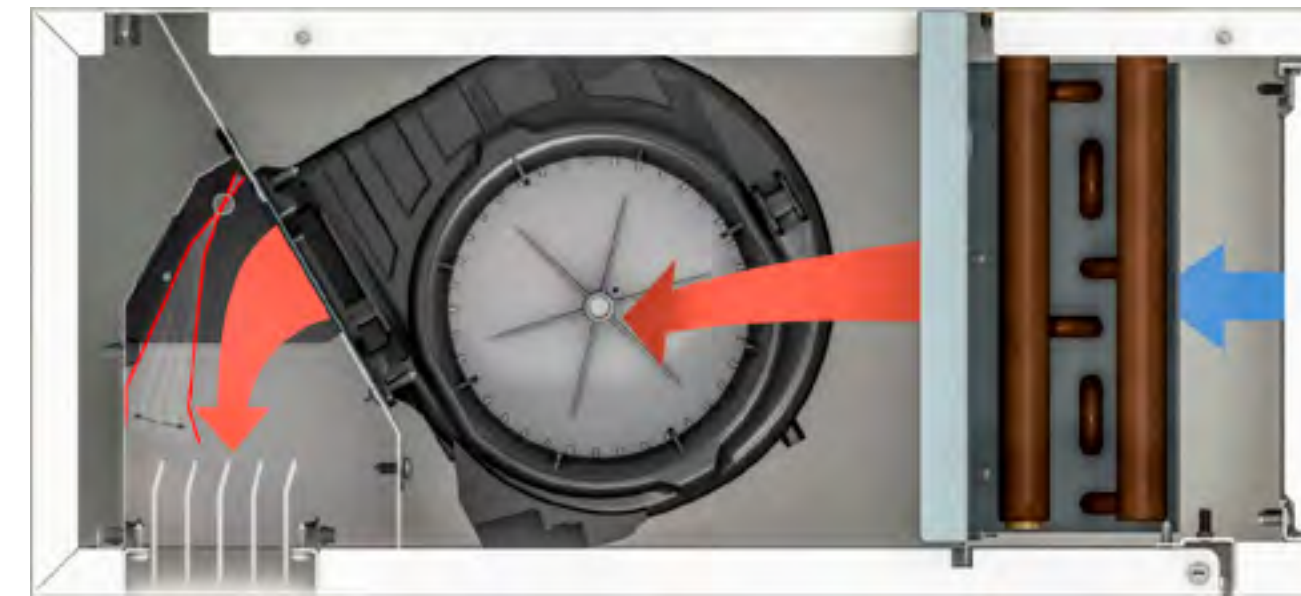
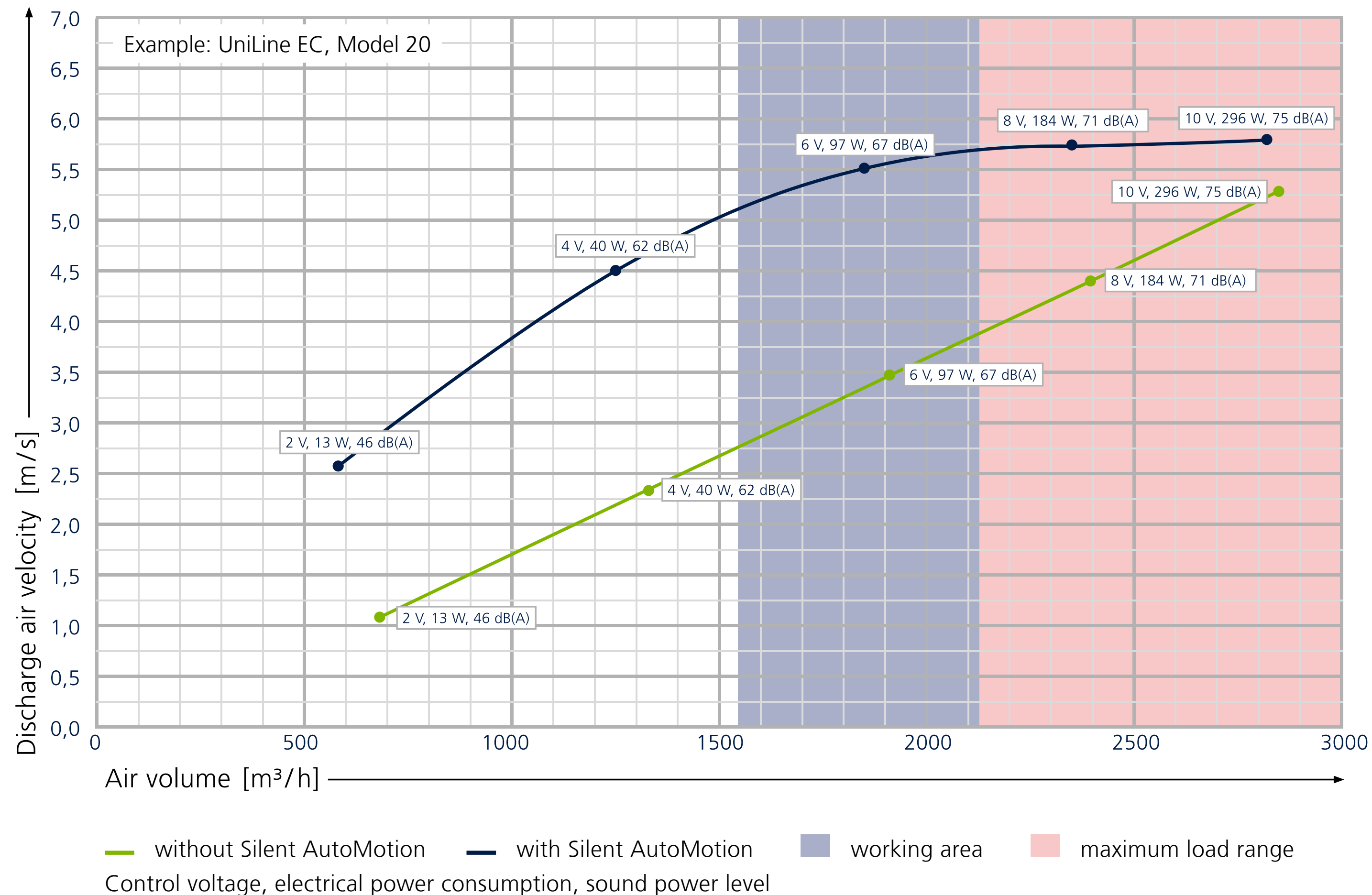

UniLine door air curtains are equipped ex works with SAM-function. This creates higher air outlet speeds with lower air volumes by reducing the outlet cross-section. The flap fully opens at maximum air volume. Open entrances can now be efficiently screened with minimal power consumption and low sound power levels.

The diagram shows the air outlet velocity above the air volume without Silent AutoMotion (green curve) and with Silent AutoMotion (blue curve), as well as the working range (highlighted in blue) and the maximum load range (highlighted in red).

The maximum air outlet velocity for efficient screening is reached in the working range between 5 and 7 V. Unlike the conventional air outlet without SAM-function at 10 V actuation (296 V electrical power consumption, 75 dB (A)), the air outlet velocity with the new air outlet with SAM-function is achieved at 6 V (97 V electrical power consumption, 67 dB (A) sound power).

This leads to a reduced sound power level of approx. 8 dB(A) and a 67% saving of electrical energy at the same penetration depth providing the local conditions permit the heat output to be reduced.

With more exacting requirements (e.g. with extremely adverse conditions), the heat output required can be adapted by increasing the air volume in the maximum load range.

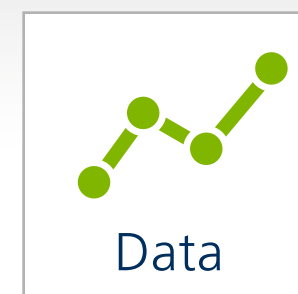
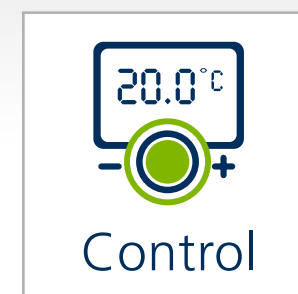
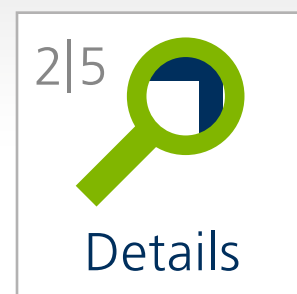
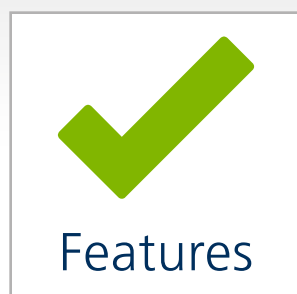

Service flap

- ▶ easy and quick to fold down
- ▶ rapid access for maintenance work



Air inlet grille

- ▶ opens with minimum effort
- ▶ easy filter replacement without the use of any tools

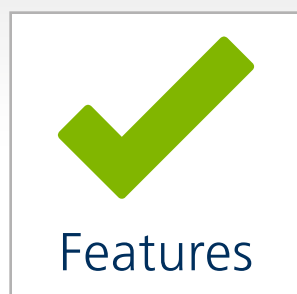

Features

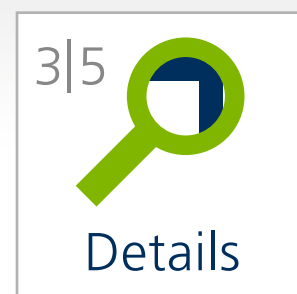

Details

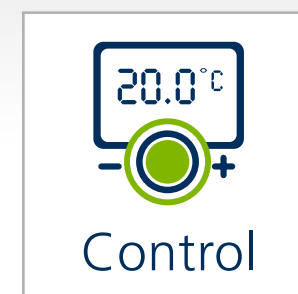

Control

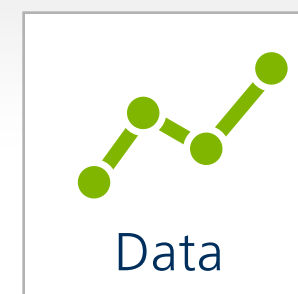

Data

Radial fan

- ▶ high-performance radial fans for high air volumes
- ▶ wired ready for connection
- ▶ switchable between 5 stages (AC) or continuously variable (EC)



Anti-twist device for heating connection

- ▶ prevents damage to the convector when screwing in the valves
- ▶ optional: valves (accessories)

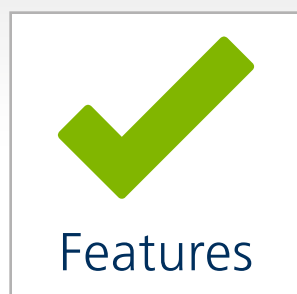

Features

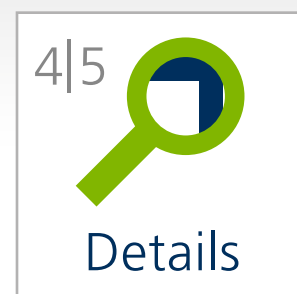

Details

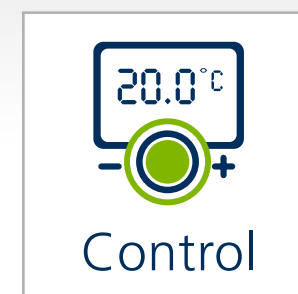

Control

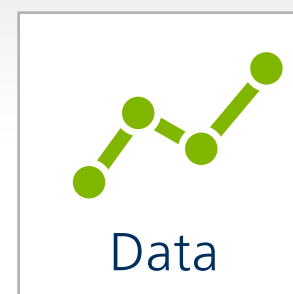

Data

High-performance heat exchanger

- ▶ a proven combination of copper/aluminium
- ▶ optimised for air flow and heat dissipation



Outlet air rectifier

- ▶ provides for a commutated low-turbulence air outlet
- ▶ with Silent AutoMotion technology for efficient screening at low operating states

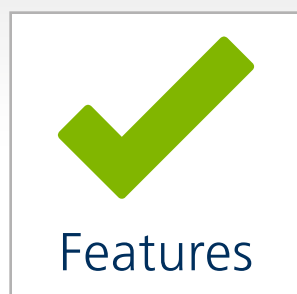

Features

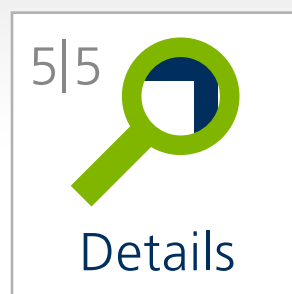

Details

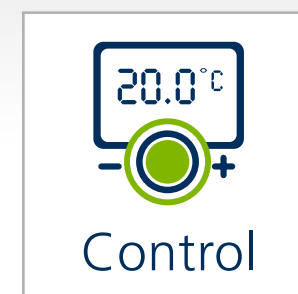

Control

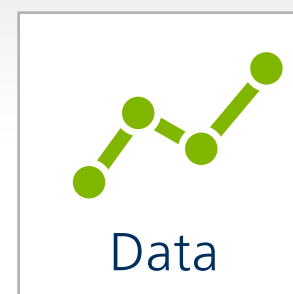

Data

Control options

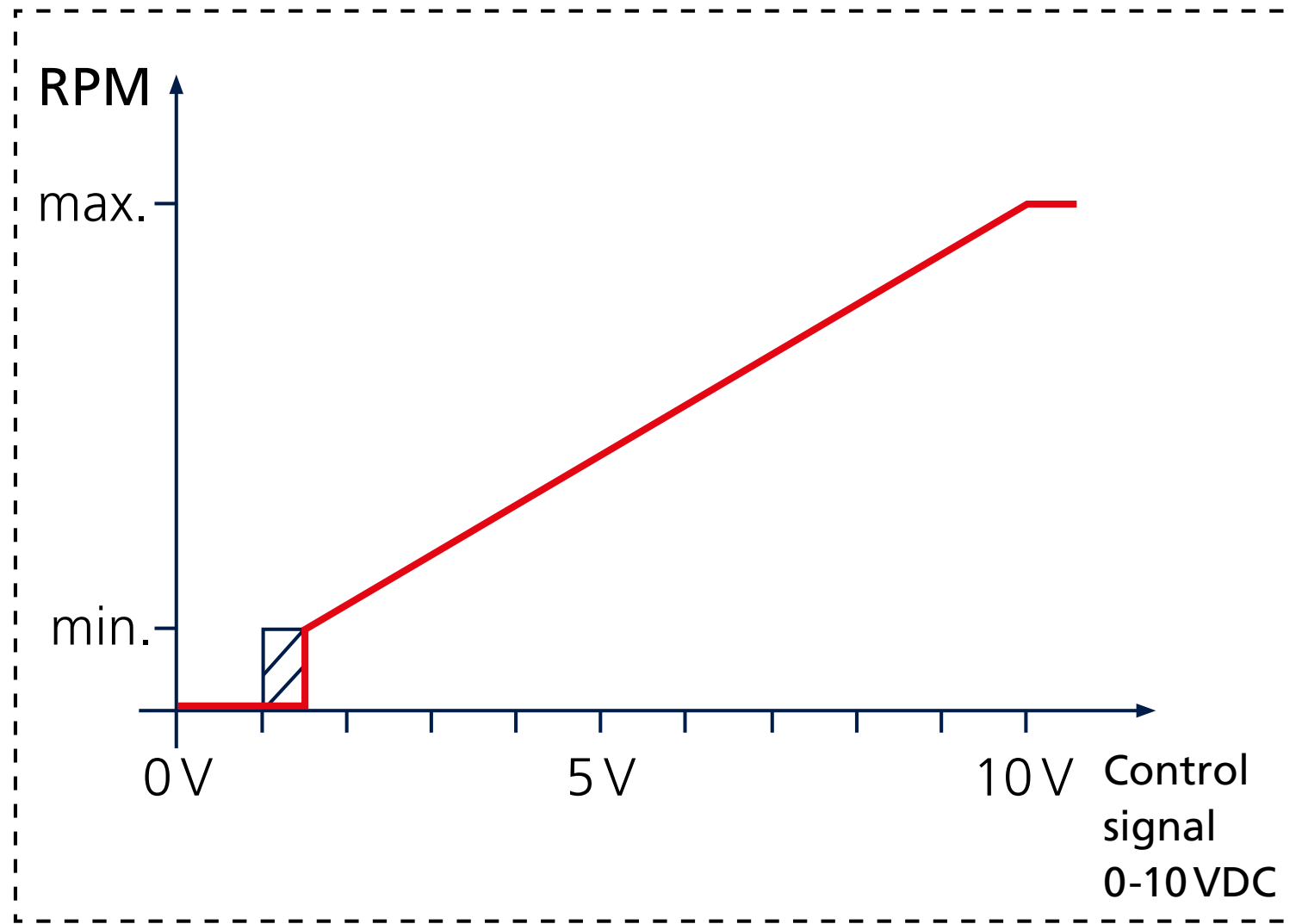

0 – 1.5 V = device OFF

1.5 – 10 V = fan speed min... 100 %

Control via BMS-system

Units available with BMS interface or local controller

BMS-Interface/ electromechanical (-00)

- ▶ power supply: 230V/50 Hz via factory fitted transformer
- ▶ fan speed control 0–100 % via 0–10 VDC BMS contact valve control, direct by BMS

Combined controller



- ▶ fan speed control 0-100 %
- ▶ operation mode switch standby, winter and summer
- ▶ control input door contact for automatic speed-up and device release
- ▶ optional: room temperature mode (standby mode) in absence operation

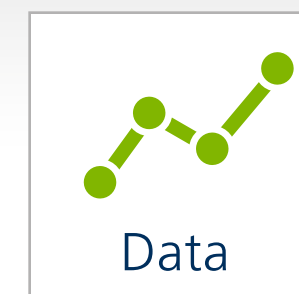
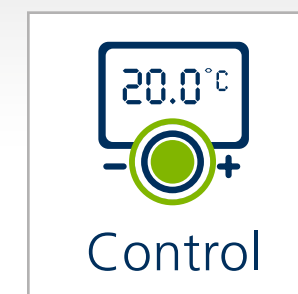
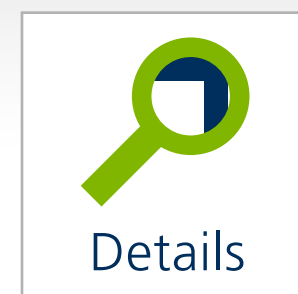
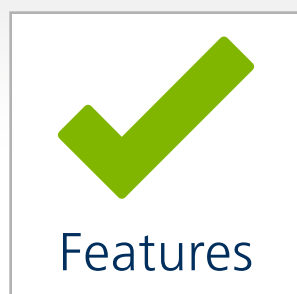

Performance data

Size	Max. discharge height ¹⁾	Max. door width	Air flow volume ²⁾	Heat output ³⁾	Sound pressure level ⁴⁾
	[m]	[m]	[m ³ /h]	[kW]	[dB(A)]
UniLine with AC motor					
10	2,3–3,0	1,0	600–1390	6,7–10,2	38–59
15	2,3–3,0	1,5	930–2130	9,6–17,4	39–60
20	2,3–3,0	2,0	1210–2820	13,1–24,2	41–61
25	2,3–3,0	2,5	1660–4000	18,0–33,9	42–62
30	2,3–3,0	3,0	2210–5330	24,1–44,2	44–64
UniLine with EC motor					
10	2,3–3,0	1,0	290–1410	3,4–10,3	27–56
15	2,3–3,0	1,5	410–2540	5,3–19,5	31–57
20	2,3–3,0	2,0	580–2820	7,6–24,1	30–59
25	2,3–3,0	2,5	710–3980	9,6–33,7	33–60
30	2,3–3,0	3,0	810–5080	11,1–42,8	34–60

¹⁾ at good to average pressure ratios/requirements/conditions

²⁾ switchable in 5 stages or continuously variable

³⁾ at LPHW 75/65 °C, EAT = 20 °C

⁴⁾ the sound pressure levels were calculated based on an expected room insulation of 16 dB(A). This corresponds to a distance of 3 m, a room volume of 2000 m³ and a reverberation time of 1.0 s (in accordance with VDI 2081).

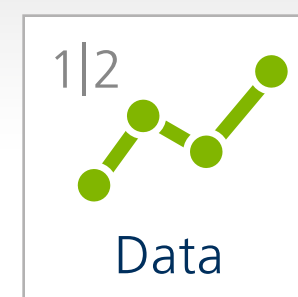
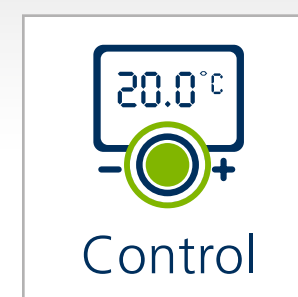
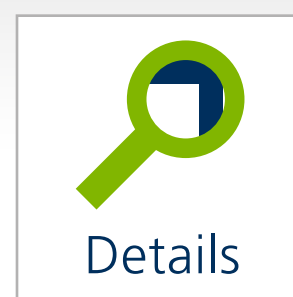
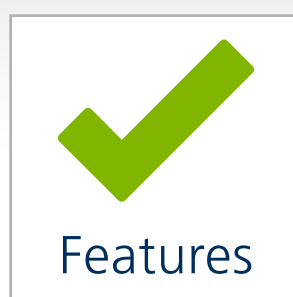

Dimensions

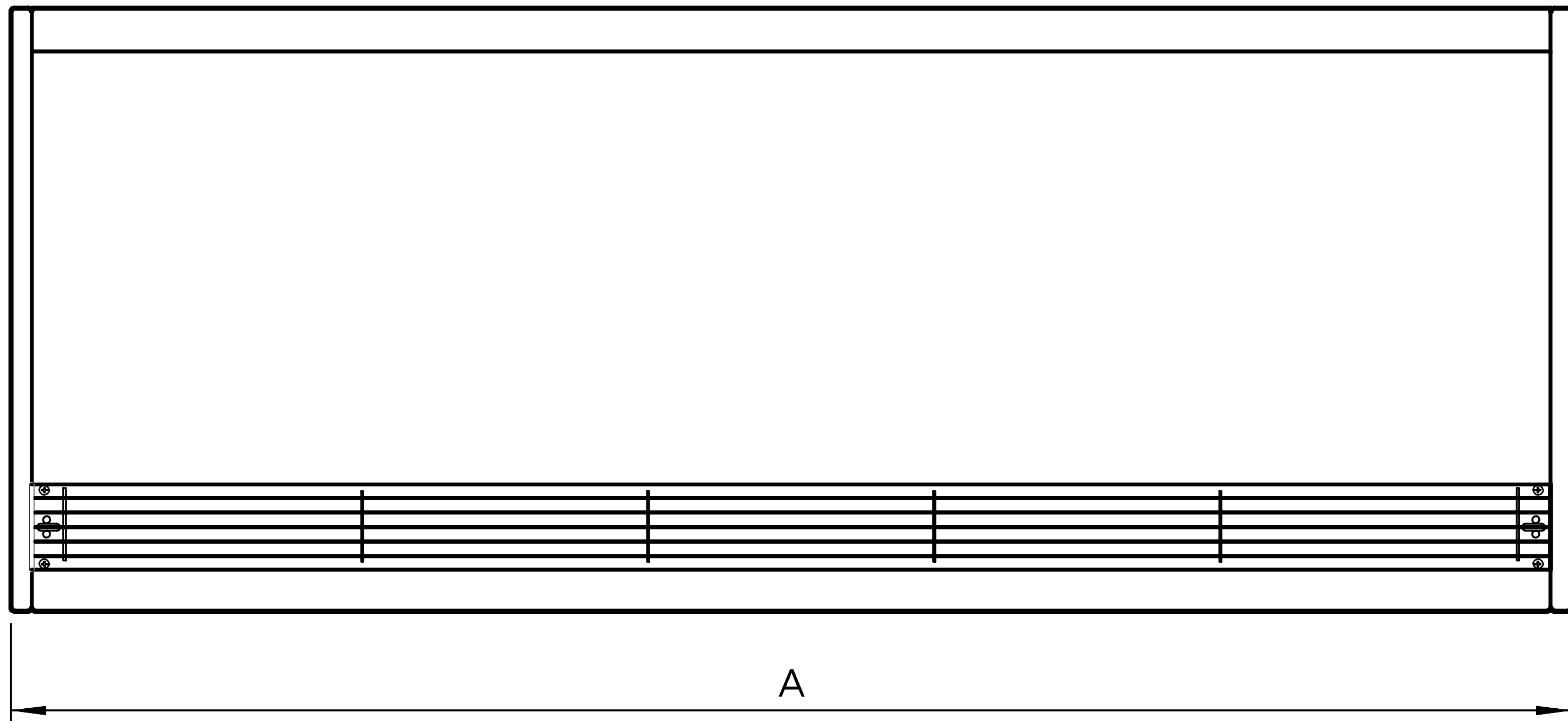

View from below

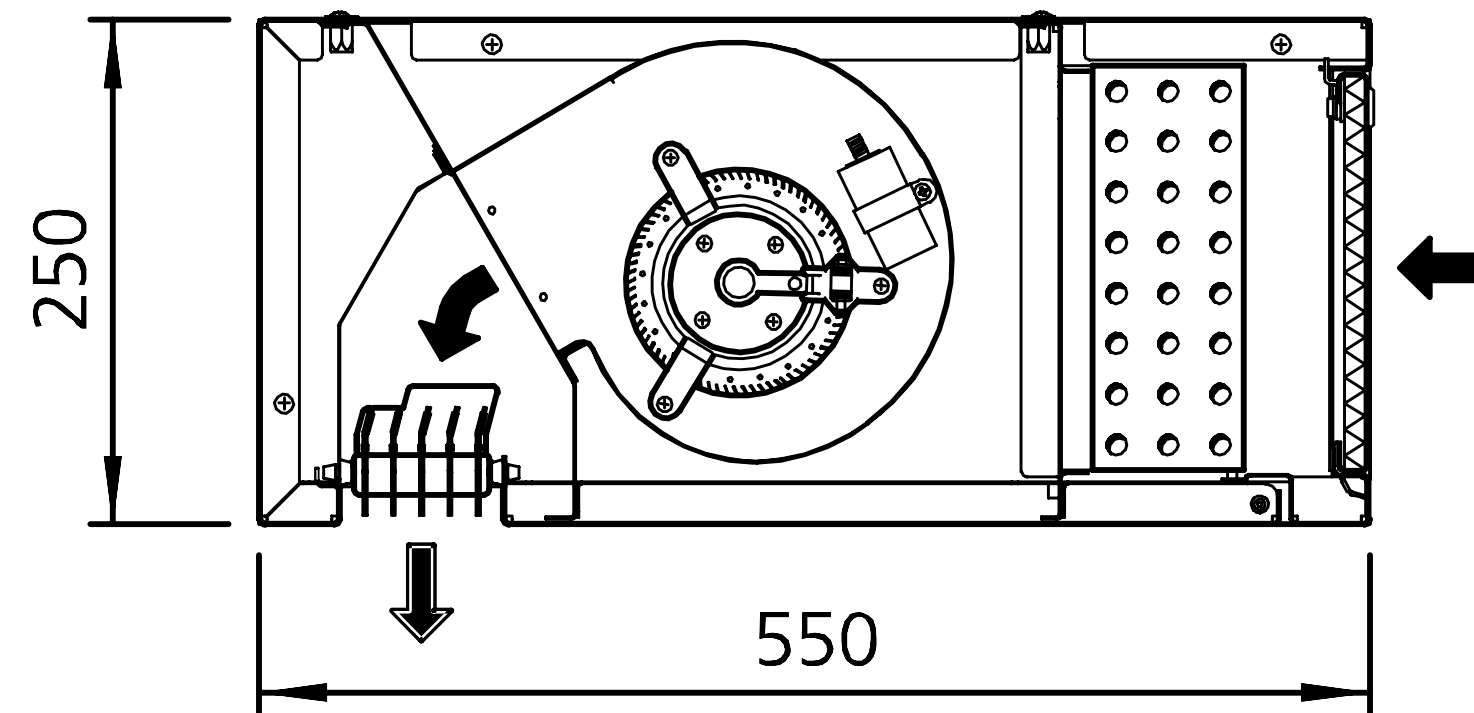

Cross section

Size	A [mm]
10	1000
15	1500
20	2000
25	2500
30	3000

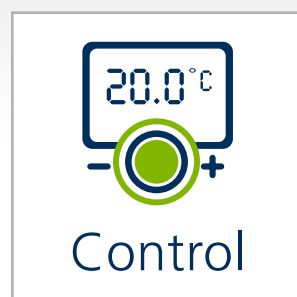
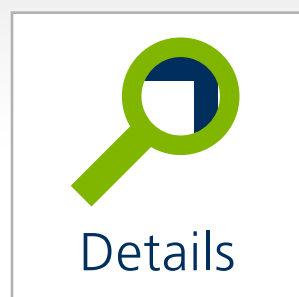
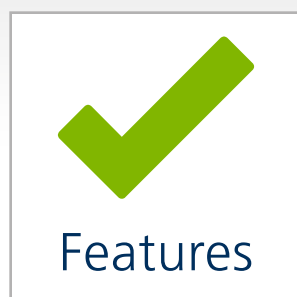

Benefits for you!

Kampmann offers you the following service benefits:

- ▶ on-site consultation
- ▶ design support
- ▶ system solutions
- ▶ detailed discussions
- ▶ After Sales Service

Find your contact person here:

[Kampmann.co.uk/contact](https://www.kampmann.co.uk/contact)

