



► **ProtecTor**
Door air curtains

ProtecTor

Door air curtain with ambient air and heated air streams for effective screening across large industrial doorways

► **Technical catalogue**

Kampmann.co.uk/protector

Contents

01 ▶ Product information	6
▶ Overview	7
▶ Product data	8
▶ Selection guide	9
▶ ProtecTor at a glance	10
02 ▶ Technical data	12
▶ Information on use	13
▶ ProtecTor - max. discharge height or width 3.5 m, Version AC fan	14
▶ ProtecTor - max. discharge height or width 3.5 m, Version EC fan	22
▶ ProtecTor - max. discharge height or width 4.5 m, Version AC fan	30
▶ ProtecTor - max. discharge height or width 4.5 m, Version EC fan	38
03 ▶ Design information	46
▶ Information on planning and design	47
▶ Discharge-side accessories	48
04 ▶ Control	52
▶ Stage switch / fan speed controller for 400 V AC and 230 V EC motors	53
▶ 2-stage three-phase motor	54
▶ Control accessories for EC recirculating air *00	57
▶ 230V EC motor	58
▶ KaControl – The all-inclusive solution for 400 V AC and 230 V EC motors	62
▶ Single-circuit control system	65
▶ Multi-circuit control	68
05 ▶ Ordering information	70
▶ ProtecTor	70
▶ Accessories	88



ProtecTor:
Door air curtain with
ambient air and heated
air streams for screening
of industrial doorways.



ProtecTor door air curtains effectively screen incoming cold air in the loading bay in Heineken's "Volga" subsidiary in Nizhny Novgorod in the heart of Russia.

01 ▶ Product information



ProtecTor – Enhanced space by doorways

The screening effect of ProtecTor door air curtains creates a comfortable indoor climate with open doors.

The perceptible warm air stream creates a rapid feeling of comfort around people especially at low outside temperatures.

Unlike conventional door air curtains, a patented dynamic and self-regulating ambient air stream provides for more effective and energy-saving screening of cold air from outdoors. The cold ambient air stream has a greater penetration depth than the warm air stream and acts as a back-up air stream. The contraction of both air streams causes the ambient air stream to entrain the warm air stream downwards with it.

Adverse energy-intensive turbulence occurs primarily between the outside air and the unheated ambient air stream. The Coanda effect produces even greater penetration depth: The contraction of both air streams causes the ambient air stream to entrain the warm air stream downwards with it, enabling the unit to be installed at a greater height.

Operating principle

Air is drawn in through the whisper-quiet sickle-blade fan and is blown through/past the heat exchanger into the air discharge nozzle. The cross-counterflow design of the heat exchanger is ideal for large temperature spreads.

Air outlet

The ProtecTor can be supplied as standard with three different standard nozzles to ideally cover all requirements on site.

Coanda effect

- ▶ Increased penetration depth of both air streams: the ambient air stream pulls the warm air stream along with it
- ▶ Ambient air stream acts as a back-up stream: it automatically optimises as the fan speed changes to match the warm air stream

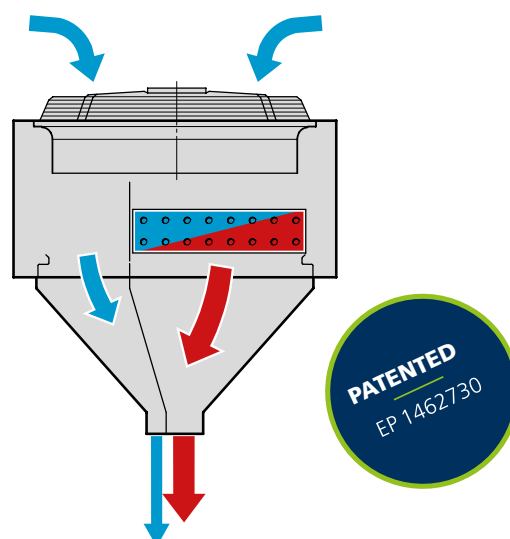

Product data



Product benefits

- ▶ Up to 38% energy savings through the patented separation of ambient and warm air streams
- ▶ Coanda effect between the ambient and warm air streams
- ▶ Self-optimising back-up air stream when the fan speed changes
- ▶ Effective cold air screening across open industrial doorways
- ▶ Patented, self-regulating generation of ambient and warm air stream (Tandem technology)
- ▶ Improved use of space close to the doorway
- ▶ Fast return of investment with Kampmann door screening
- ▶ Officially verified property right: European Patent EP 1462730



Features

- ▶ 2-stage direct current motor or continuously variable EC motor
- ▶ Different outlet nozzles are available
- ▶ Patented Tandem technology with ambient and warm air stream
- ▶ Unit and accessories available powder-coated in RAL colours
- ▶ Extensive range of control accessories

Installation

- ▶ Horizontal
- ▶ Standing

Door Air Curtains

- ▶ Ambient and warm air stream

Motors

- ▶ AC and EC

Discharge height

- ▶ 3.5 - 4.5 m

Performance data

Max. door width or height [m] > 2.25 – 5.25

Max. discharge height or width [m] > 3.5 – 4.5

Heat output [kW]¹⁾ > 15.0 – 179.0

Air flow [m³/h]²⁾ > 940 – 44190

Sound pressure level [dB(A)]³⁾ > 20 – 70

¹⁾ at LPHW 75/65 °C, $t_{r1} = 20$ °C

²⁾ switches between 5 stages or continuously variable control

³⁾ The sound pressure levels were calculated with an assumed room insulation of 16 dB(A). This corresponds to a distance of 5 m, a room volume of 3000 m³ and a reverberation time of 2.0 s (in accordance with VDI 2081).

Operating limits

- ▶ Max. operating pressure: 10 bar with copper/aluminium, 16 bar with galvanised steel
- ▶ Max. entering water temperature: 120 °C
- ▶ Min. entering water temperature: 40 °C
- ▶ Inlet air temperature: 40 °C
- ▶ Max. glycol volume: 50 %
- ▶ Models for higher operating conditions available on request

Applications

ProtecTor door air curtains efficiently screen cold air across open doorways in industrial buildings.



Selection guide

Model size	Length (A) [mm]	Dimensions		Max. discharge height or width [m]	Max. door width or height [m]	Heat exchanger model		
		Depth (B) [mm]	Height (C) [mm]			copper/aluminium Heat output ¹⁾ [kW]	steel, galvanised Heat output ¹⁾ [kW]	steel, galvanised cross-counterflow Heat output ²⁾ [kW]
20	2000	740	360	3.5	2.25	15.0 – 49.7	15.0 – 49.7	10.0 – 27.9
30	3000				3.25	22.4 – 74.5	22.4 – 74.5	15.0 – 42.0
40	4000				4.25	30.0 – 99.4	30.0 – 99.4	19.9 – 56.0
50	5000				5.25	37.3 – 123.9	37.3 – 123.9	24.8 – 69.4
20	2000				840	4.5	2.25	22.4 – 71.3
30	3000	3.25	33.7 – 107.3	33.7 – 107.3			25.4 – 73.1	
40	4000	4.25	45.1 – 143.5	45.1 – 143.5			34.0 – 97.9	
50	5000	5.25	56.2 – 179.0	56.2 – 179.0			42.3 – 121.9	

¹⁾ at LPHW 75/65 °C, $t_{\text{cl}} = 20$ °C

²⁾ at LPHW 80/40 °C, $t_{\text{cl}} = 20$ °C

Technical drawing (Dimensions in mm)

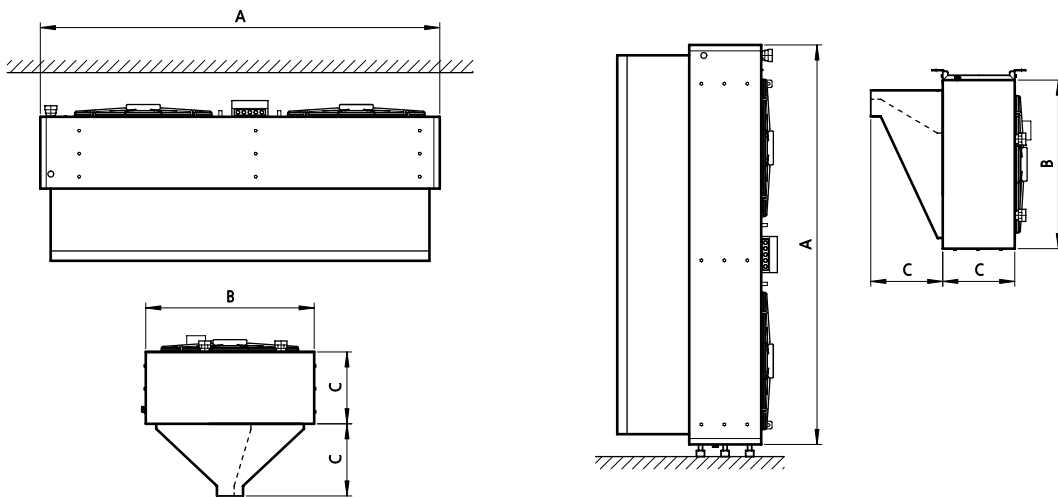

ProtecTor at a glance



Supply (2") 1

Return (2") 2

PowerKon heat exchanger A

Air discharge nozzle (shown: central air discharge) 2

Features



A PowerKon heat exchanger

- ▶ copper/aluminium heat exchanger, especially lightweight, with high heat outputs from minimal dimensions
- ▶ galvanised steel
- ▶ galvanised steel, cross-counterflow
- ▶ suitable for low temperature heating systems and LPHW heating systems



B Whisper-quiet, sickle-blade fan, ErP 2015-compliant:

- ▶ continuously variable EC single-phase or 2-stage three-phase whisper-quiet sickle-blade fan
- ▶ excellent efficiency due to the aerodynamic design of the rotor housing
- ▶ electrical thermal class THCL 155 version
- ▶ motor protection: IP 54
- ▶ balanced at two levels; balancing quality according to G 6.3 DIN ISO 1940 Part 1

Information on use

Ideally, door air curtains should have a largely continuous air discharge opening to cover the entire width or height of the doorway. The leaving air temperature should be controllable, depending on the heat or cooling requirement in the building. In heating mode, preferably design the leaving air temperature at 32 °C, although 36 °C is recommended. This requirement applies to the room-side air stream with multi-stream systems.

European patent

The European Patent Office issued a European patent at the start of 2016 for the ProtecTor door air curtain. The unique feature of the ProtecTor air curtain is its air flow. The ProtecTor features a multi-stream air discharge nozzle with two adjacent air streams. An unheated ambient air stream acts as a back-up air stream and automatically adapts to the air volume of the heated air stream when the fan speed changes.

The heated air is protected by the ambient air stream and cannot escape to the outside. The ambient air stream has a greater flow velocity than the warm air stream and so acts as a back-up air stream, ensuring the greater stability of the air stream and greater penetration depth.

Compliance with the ErP Directive 2015

The European Commission's ErP Directive ("Energy-related Products") evaluates and modifies the requirements of technical products in energy-related applications. According to the ErP Directive (EU) 327/2011 ("LOT 11"), the efficiency requirements have been tightened on fans with an electric drive output of 125 watts to 500 kilowatts. A number of fans can no longer be marketed since the second stage entered into force on 1 January 2015.

The inlet nozzle used in the unit must be taken into account along with the fan, in terms of energy. ProtecTor door air curtains are solely equipped with ErP-compliant fans.

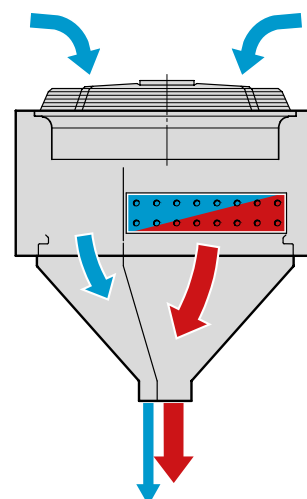
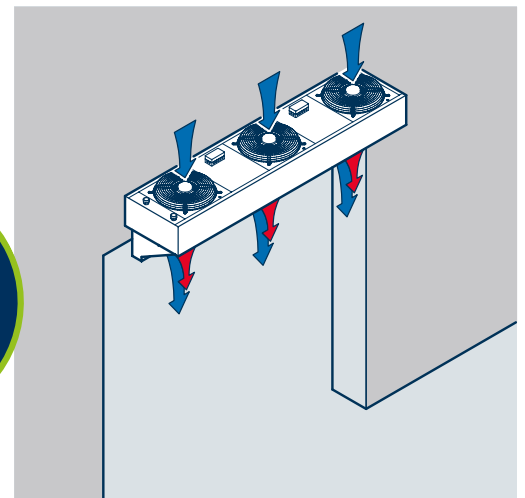
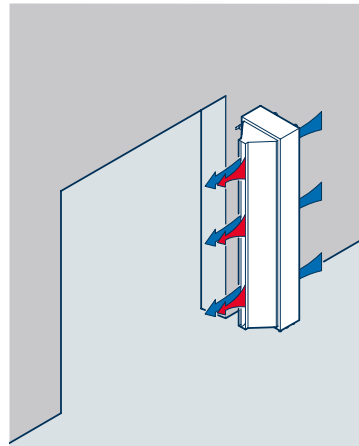

ProtecTor

Max. discharge height or width 3.5 m

Model size 20

Version AC fan

Technical drawing (Dimensions in mm)

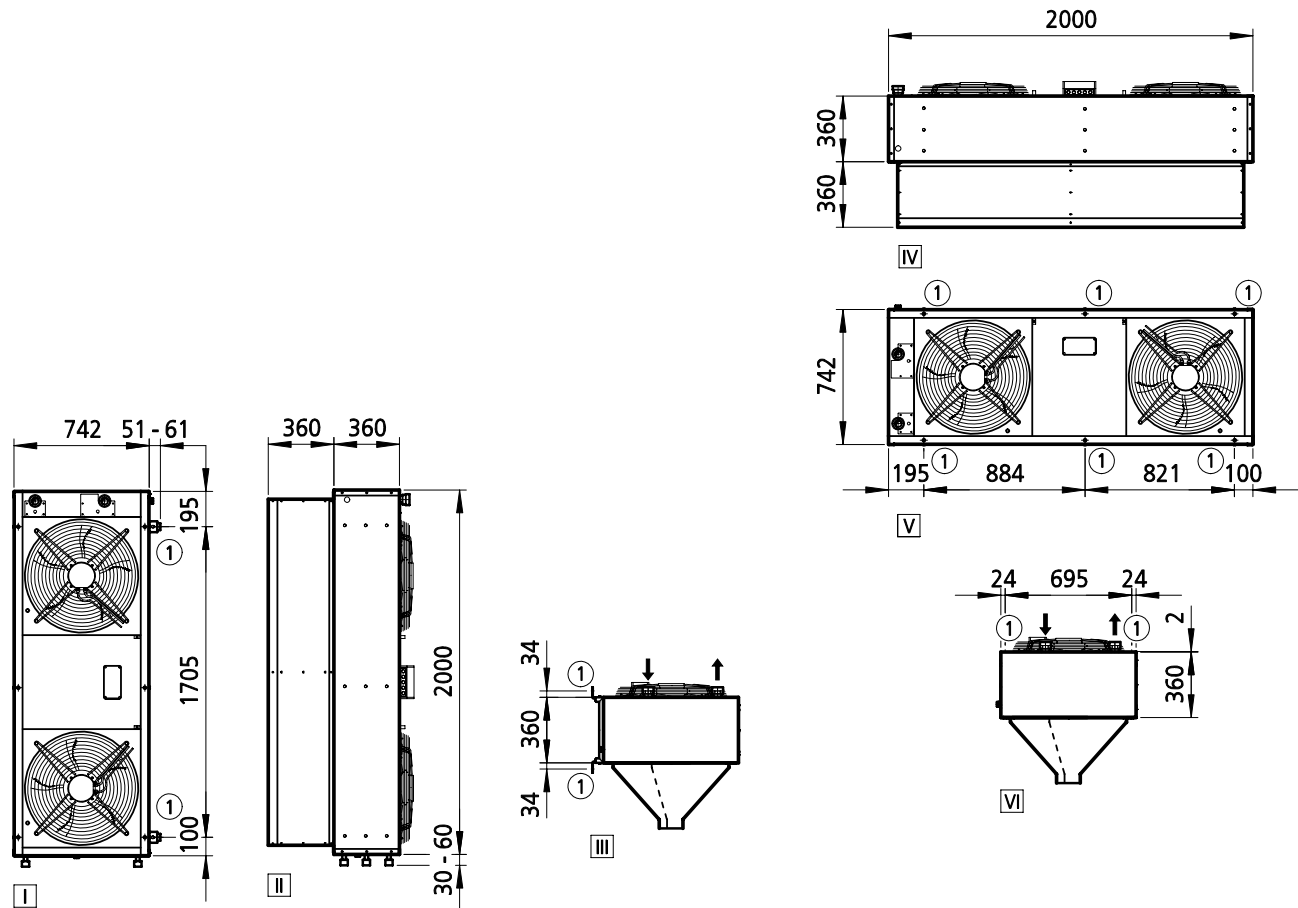

View

- I Side view, standing/upright model
- II Front view, standing/upright model
- III Top view, standing/upright model
- IV Front view, horizontal model
- V Top view, horizontal model
- VI Side view, horizontal model

More information

- ① Fixing point

Specifications

Type	Heat exchanger model	Weight, max. [kg]	Water content [l]
*200066	without heat exchanger	81	---
*202066	copper/aluminium	104	7.7
*203166	steel, galvanised	198	16.3
*203366	steel, galvanised cross-counterflow	192	16.3

Performance data

Type	Heat exchanger model	Max. door width or height	Max. discharge height or width ¹⁾	Switching stage	Air flow			Heat output				Sound pressure level ³⁾	Sound power level
					Total	Ambient air stream	Warm air	at LPHW 75/65 °C ²⁾		at LPHW 80/40 °C ²⁾			
		[m]	[m]		[m ³ /h]	[m ³ /h]	[m ³ /h]	[kW]	[°C]	[kW]	[°C]	[dB(A)]	[dB(A)]
*202066	copper/aluminium	2.25	3.5	2	9250	3450	5800	43.3	42.0	---	---	61	77
				1	7300	2700	4600	33.3	41.2	---	---	54	70
*203166	steel, galvanised	2.25	3.5	2	9250	3450	5800	43.3	42.0	---	---	61	77
				1	7300	2700	4600	33.3	41.2	---	---	54	70
*200066	without heat exchanger	2.25	3.5	2	10400	–	–	---	---	---	---	61	77
				1	8160	–	–	---	---	---	---	54	70
*203366	steel, galvanised cross-counter-flow	2.25	3.5	2	9250	3450	5800	---	---	27.0	33.7	61	77
				1	7300	2700	4600	---	---	24.1	35.4	54	70

Use our calculation tools on our website to easily calculate heat outputs and other technical data with just a few clicks!

► <https://www.kampmann.co.uk/hvac/products/door-air-curtains/protector#Calculate-performance-data>

¹⁾ at low to medium pressure conditions / requirements / circumstances, in conjunction with long outlet nozzle

²⁾ with air intake temperature_i = 20°C, t_u based on warm air stream

³⁾ The sound pressure levels were calculated with an assumed room insulation of 16 dB(A). This corresponds to a distance of 5 m, a room volume of 3000 m³ and a reverberation time of 2.0 s (in accordance with VDI 2081).

ProtecTor

Max. discharge height or width 3.5 m

Model size 30

Version AC fan

Technical drawing (Dimensions in mm)

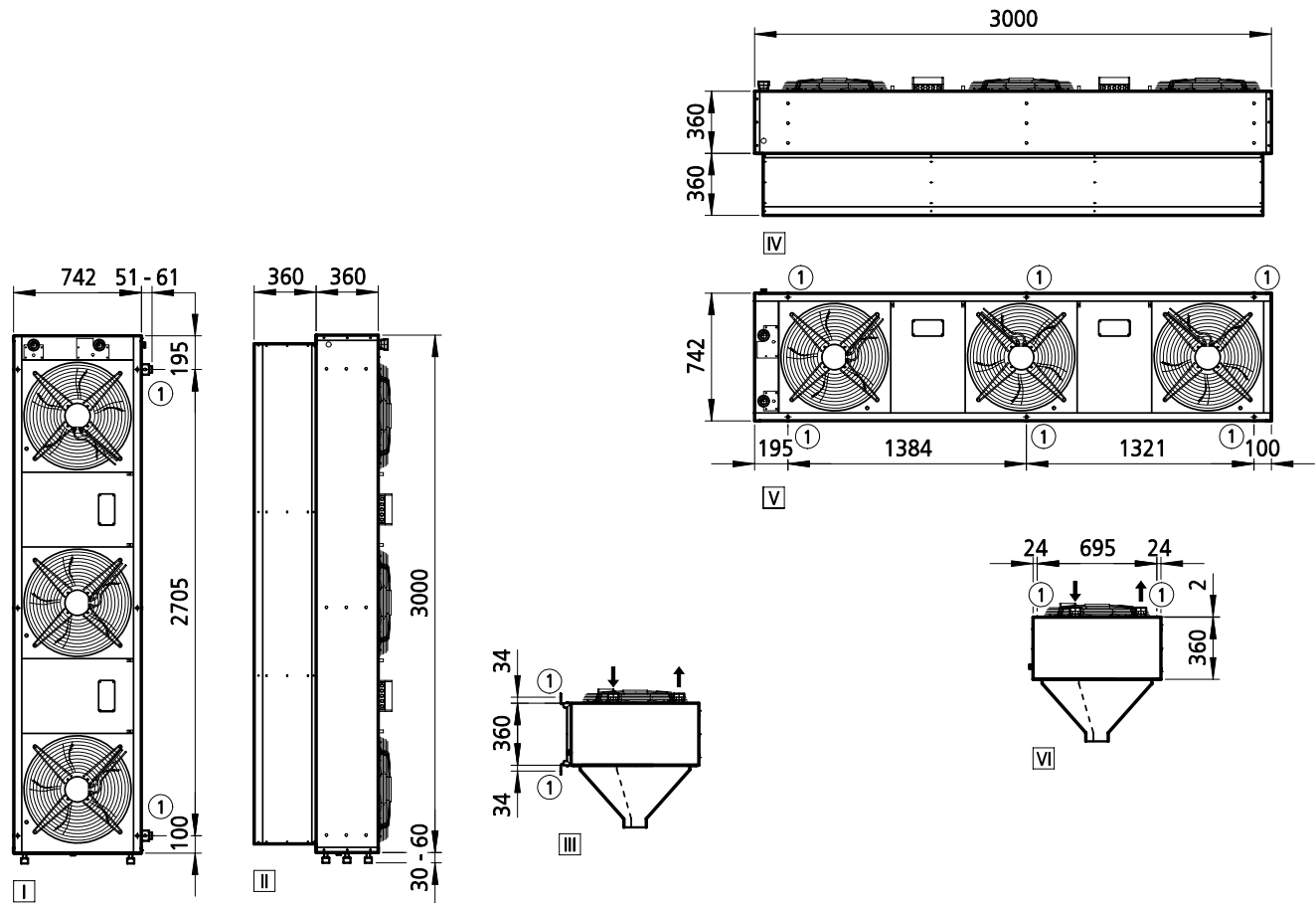

View

- I Side view, standing/upright model
- II Front view, standing/upright model
- III Top view, standing/upright model
- IV Front view, horizontal model
- V Top view, horizontal model
- VI Side view, horizontal model

More information

- ① Fixing point

Specifications

Type	Heat exchanger model	Weight, max. [kg]	Water content [l]
*300066	without heat exchanger	111	---
*302066	copper/aluminium	146	10.8
*303166	steel, galvanised	288	22.8
*303366	steel, galvanised cross-counterflow	281	22.8

Performance data

Type	Heat exchanger model	Max. door width or height	Max. discharge height or width ¹⁾	Switching stage	Air flow			Heat output				Sound pressure level ³⁾	Sound power level
					Total	Ambient air stream	Warm air	at LPHW 75/65 °C ²⁾		at LPHW 80/40 °C ²⁾			
		[m]	[m]		[m ³ /h]	[m ³ /h]	[m ³ /h]	[kW]	[°C]	[kW]	[°C]	[dB(A)]	[dB(A)]
*302066	copper/aluminium	3.25	3.5	2	13900	5200	8700	65.0	42.0	---	---	63	79
				1	11000	4080	6920	50.0	41.3	---	---	56	72
*303166	steel, galvanised	3.25	3.5	2	13900	5200	8700	65.0	42.0	---	---	63	79
				1	11000	4080	6920	50.0	41.3	---	---	56	72
*300066	without heat exchanger	3.25	3.5	2	15600	–	–	---	---	---	---	63	79
				1	12250	–	–	---	---	---	---	56	72
*303366	steel, galvanised cross-counter-flow	3.25	3.5	2	13900	5200	8700	---	---	41.1	33.9	63	79
				1	11000	4080	6920	---	---	36.7	35.6	56	72

Use our calculation tools on our website to easily calculate heat outputs and other technical data with just a few clicks!

► <https://www.kampmann.co.uk/hvac/products/door-air-curtains/protector#Calculate-performance-data>

¹⁾ at low to medium pressure conditions / requirements / circumstances, in conjunction with long outlet nozzle

²⁾ with air intake temperature_i = 20°C, t_z based on warm air stream

³⁾ The sound pressure levels were calculated with an assumed room insulation of 16 dB(A). This corresponds to a distance of 5 m, a room volume of 3000 m³ and a reverberation time of 2.0 s (in accordance with VDI 2081).

ProtecTor

Max. discharge height or width 3.5 m

Model size 40

Version AC fan

Technical drawing (Dimensions in mm)

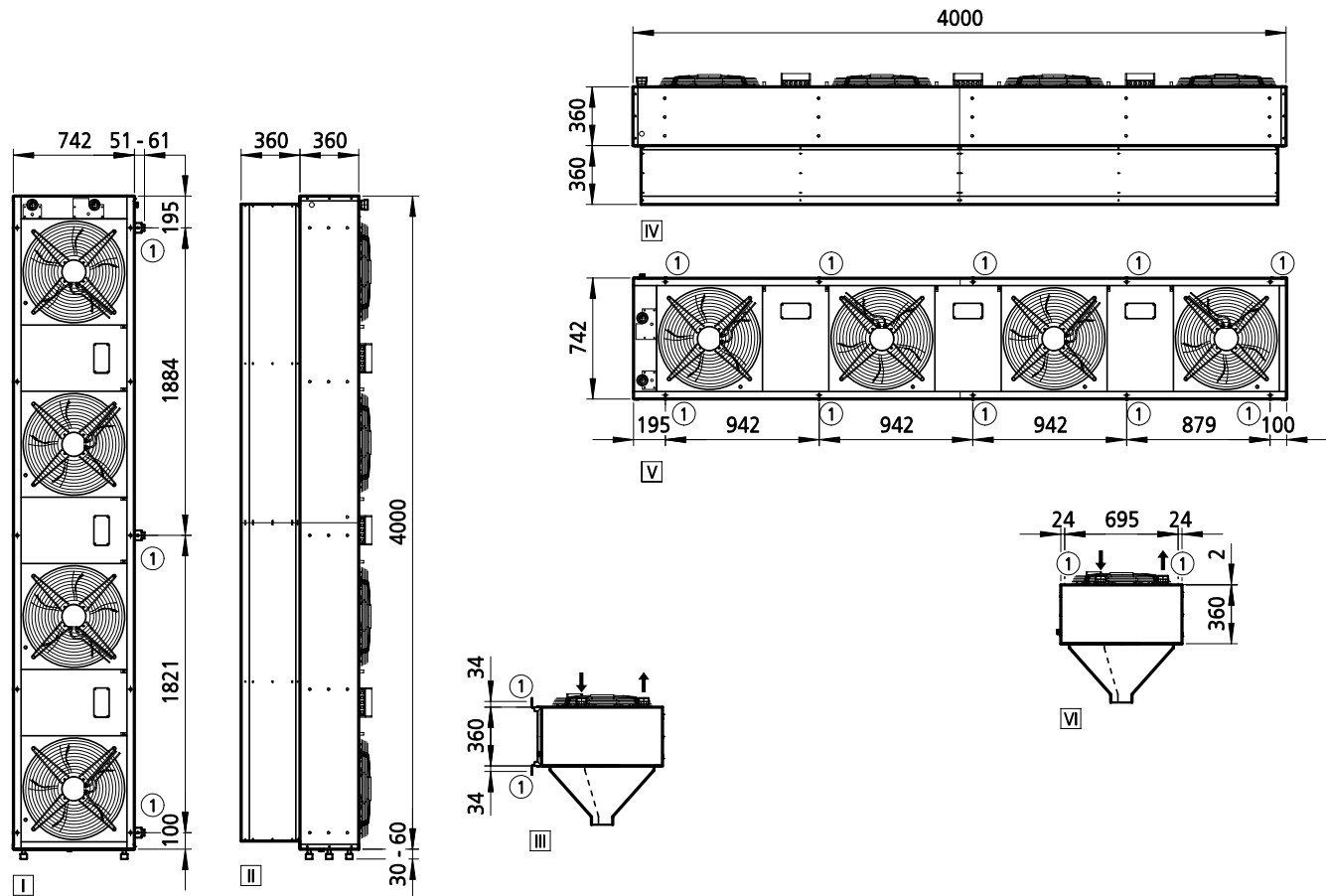

View

- I Side view, standing/upright model
- II Front view, standing/upright model
- III Top view, standing/upright model
- IV Front view, horizontal model
- V Top view, horizontal model
- VI Side view, horizontal model

More information

- ① Fixing point

Specifications

Type	Heat exchanger model	Weight, max. [kg]	Water content [l]
*400066	without heat exchanger	147	---
*402066	copper/aluminium	195	13.9
*403166	steel, galvanised	384	29.3
*403366	steel, galvanised cross-counterflow	376	29.3

Performance data

Type	Heat exchanger model	Max. door width or height	Max. discharge height or width ¹⁾	Switching stage	Air flow			Heat output				Sound pressure level ³⁾	Sound power level
					Total	Ambient air stream	Warm air	at LPHW 75/65 °C ²⁾		at LPHW 80/40 °C ²⁾			
		[m]	[m]		[m ³ /h]	[m ³ /h]	[m ³ /h]	[kW]	[°C]	[kW]	[°C]	[dB(A)]	[dB(A)]
*402066	copper/aluminium	4.25	3.5	2	18500	6930	11570	86.7	42.0	---	---	64	80
				1	14700	5440	9260	66.6	41.2	---	---	57	73
*403166	steel, galvanised	4.25	3.5	2	18500	6930	11570	86.7	42.0	---	---	64	80
				1	14700	5440	9260	66.6	41.2	---	---	57	73
*400066	without heat exchanger	4.25	3.5	2	20800	–	–	---	---	---	---	64	80
				1	16300	–	–	---	---	---	---	57	73
*403366	steel, galvanised cross-counter-flow	4.25	3.5	2	18500	6930	11570	---	---	54.7	33.9	64	80
				1	14700	5440	9260	---	---	48.8	35.5	57	73

Use our calculation tools on our website to easily calculate heat outputs and other technical data with just a few clicks!
 ▶ <https://www.kampmann.co.uk/hvac/products/door-air-curtains/protector#Calculate-performance-data>

¹⁾ at low to medium pressure conditions / requirements / circumstances, in conjunction with long outlet nozzle

²⁾ with air intake temperature_i = 20°C, t_z based on warm air stream

³⁾ The sound pressure levels were calculated with an assumed room insulation of 16 dB(A). This corresponds to a distance of 5 m, a room volume of 3000 m³ and a reverberation time of 2.0 s (in accordance with VDI 2081).

ProtecTor

Max. discharge height or width 3.5 m

Model size 50

Version AC fan

Technical drawing (Dimensions in mm)

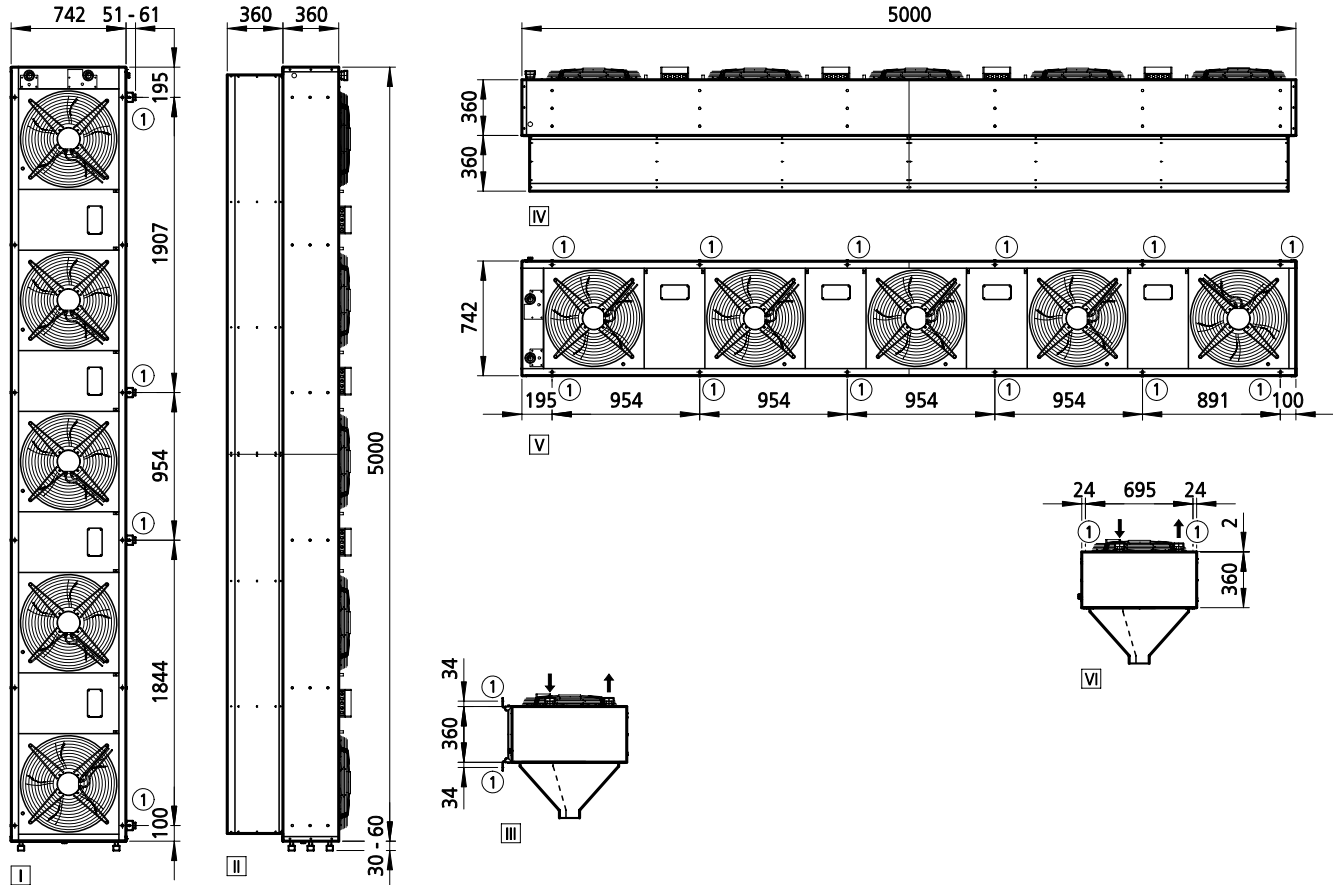

View

- I Side view, standing/upright model
- II Front view, standing/upright model
- III Top view, standing/upright model
- IV Front view, horizontal model
- V Top view, horizontal model
- VI Side view, horizontal model

More information

- ① Fixing point

Specifications

Type	Heat exchanger model	Weight, max. [kg]	Water content [l]
*500066	without heat exchanger	180	---
*502066	copper/aluminium	241	17.1
*503166	steel, galvanised	476	35.8
*503366	steel, galvanised cross-counterflow	468	35.8

Performance data

Type	Heat exchanger model	Max. door width or height	Max. discharge height or width ¹⁾	Switching stage	Air flow			Heat output				Sound pressure level ³⁾	Sound power level
					Total	Ambient air stream	Warm air	at LPHW 75/65 °C ²⁾		at LPHW 80/40 °C ²⁾			
		[m]	[m]		[m ³ /h]	[m ³ /h]	[m ³ /h]	[kW]	[°C]	[kW]	[°C]	[dB(A)]	[dB(A)]
*502066	copper/aluminium	5.25	3.5	2	23200	8700	14500	108.3	42.0	---	---	65	81
				1	18300	6800	11500	83.3	41.3	---	---	58	74
*503166	steel, galvanised	5.25	3.5	2	23200	8700	14500	108.3	42.0	---	---	65	81
				1	18300	6800	11500	83.3	41.3	---	---	58	74
*500066	without heat exchanger	5.25	3.5	2	26100	–	–	---	---	---	---	65	81
				1	20400	–	–	---	---	---	---	58	74
*503366	steel, galvanised cross-counter-flow	5.25	3.5	2	23200	8700	14500	---	---	68.0	33.8	65	81
				1	18300	6800	11500	---	---	61.0	35.6	58	74

Use our calculation tools on our website to easily calculate heat outputs and other technical data with just a few clicks!

► <https://www.kampmann.co.uk/hvac/products/door-air-curtains/protector#Calculate-performance-data>

¹⁾ at low to medium pressure conditions / requirements / circumstances, in conjunction with long outlet nozzle

²⁾ with air intake temperature_i = 20°C, t_z based on warm air stream

³⁾ The sound pressure levels were calculated with an assumed room insulation of 16 dB(A). This corresponds to a distance of 5 m, a room volume of 3000 m³ and a reverberation time of 2.0 s (in accordance with VDI 2081).

ProtecTor

Max. discharge height or width 3.5 m
 Model size 20
 Version EC fan

Technical drawing (Dimensions in mm)

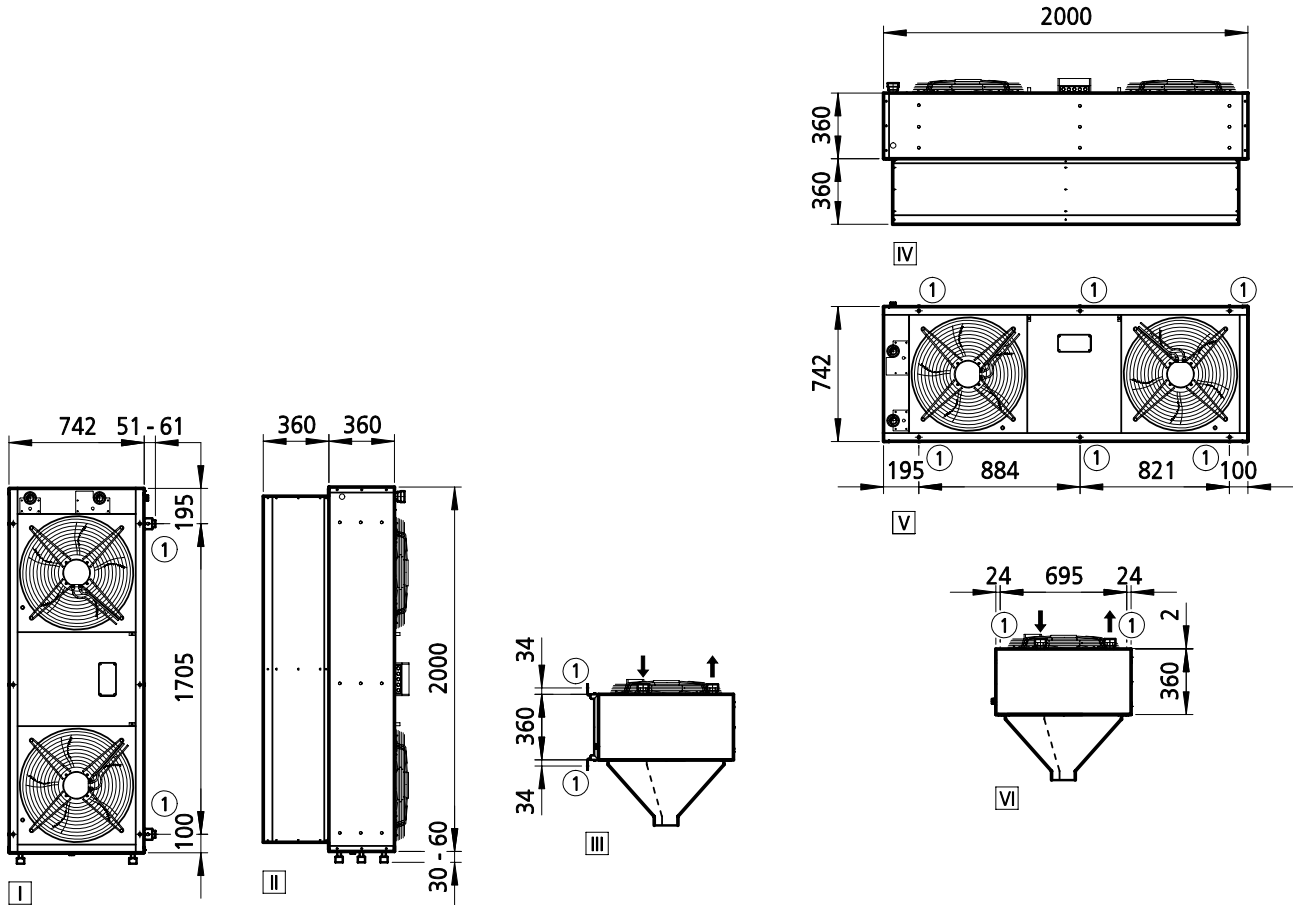

- View**
- I Side view, standing/upright model
 - II Front view, standing/upright model
 - III Top view, standing/upright model
 - IV Front view, horizontal model
 - V Top view, horizontal model
 - VI Side view, horizontal model

More information
 ① Fixing point

Specifications

Type	Heat exchanger model	Weight, max. [kg]	Water content [l]
*200068	without heat exchanger	84	---
*202068	copper/aluminium	106	7.7
*203168	steel, galvanised	198	16.3
*203368	steel, galvanised cross-counterflow	194	16.3

Performance data

Type	Heat exchanger model	Max. door width or height	Max. discharge height or width ¹⁾	Control voltage	Air flow			Heat output				Sound pressure level ³⁾	Sound power level	
					Total	Ambient air stream	Warm air	at LPHW 75/65 °C ²⁾		at LPHW 80/40 °C ²⁾				
		[m]	[m]	[V]	[m ³ /h]	[m ³ /h]	[m ³ /h]	[kW]	[°C]	[kW]	[°C]	[dB(A)]	[dB(A)]	
*202068	copper/aluminium	2.25	3.5	10	11270	4200	7070	49.7	40.7	---	---	65	81	
				8	9050	3370	5680	42.7	42.1	---	---	58	74	
				6	6390	2380	4010	33.6	44.6	---	---	50	66	
				4	4280	1600	2680	25.4	47.9	---	---	40	56	
				2	2000	750	1250	15.0	55.3	---	---	20	36	
*203168	steel, galvanised	2.25	3.5	10	11270	4200	7070	49.7	40.7	---	---	65	81	
				8	9050	3370	5680	42.7	42.1	---	---	58	74	
				6	6390	2380	4010	33.6	44.6	---	---	50	66	
				4	4280	1600	2680	25.4	47.9	---	---	40	56	
				2	2000	750	1250	15.0	55.3	---	---	20	36	
*200068	without heat exchanger	2.25	3.5	10	12600	---	---	---	---	---	---	65	81	
				8	10120	---	---	---	---	---	---	---	58	74
				6	7140	---	---	---	---	---	---	---	50	66
				4	4780	---	---	---	---	---	---	---	40	56
				2	2240	---	---	---	---	---	---	---	20	36
*203368	steel, galvanised cross-counter-flow	2.25	3.5	10	9580	3570	6010	---	---	27.9	33.7	65	81	
				8	7780	2900	4880	---	---	24.2	34.6	58	74	
				6	5580	2080	3500	---	---	19.2	36.1	50	66	
				4	3910	1460	2450	---	---	15.0	38.0	40	56	
				2	2160	810	1350	---	---	10.0	41.8	20	36	

Use our calculation tools on our website to easily calculate heat outputs and other technical data with just a few clicks!
 ▶ <https://www.kampmann.co.uk/hvac/products/door-air-curtains/protector#Calculate-performance-data>

¹⁾ at low to medium pressure conditions / requirements / circumstances, in conjunction with long outlet nozzle

²⁾ with air intake temperature_i = 20°C, t_u based on warm air stream

³⁾ The sound pressure levels were calculated with an assumed room insulation of 16 dB(A). This corresponds to a distance of 5 m, a room volume of 3000 m³ and a reverberation time of 2.0 s (in accordance with VDI 2081).

ProtecTor

Max. discharge height or width 3.5 m

Model size 30

Version EC fan

Technical drawing (Dimensions in mm)

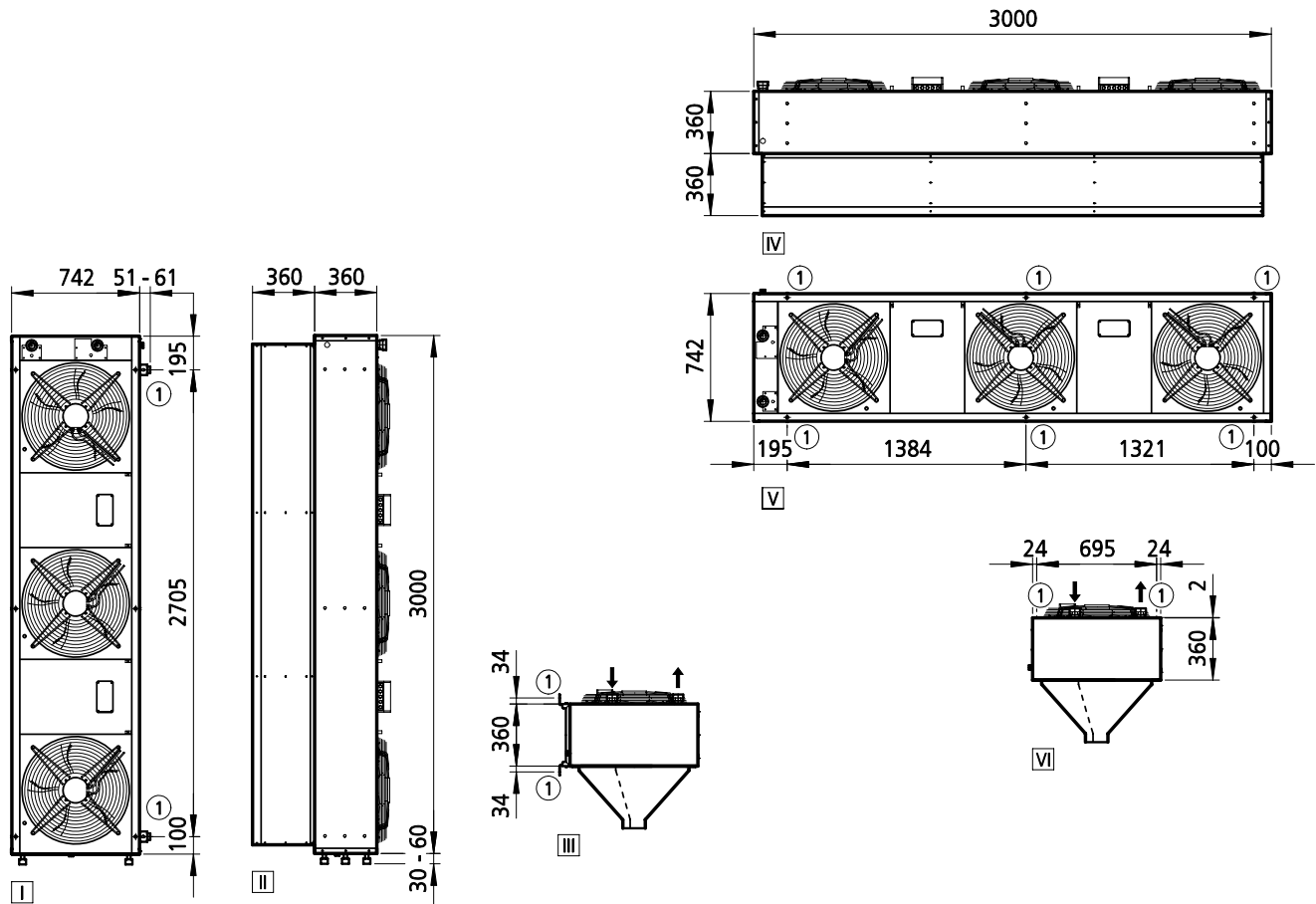

View

- I Side view, standing/upright model
- II Front view, standing/upright model
- III Top view, standing/upright model
- IV Front view, horizontal model
- V Top view, horizontal model
- VI Side view, horizontal model

More information

- ① Fixing point

Specifications

Type	Heat exchanger model	Weight, max. [kg]	Water content [l]
*300068	without heat exchanger	114	---
*302068	copper/aluminium	151	10.8
*303168	steel, galvanised	289	22.8
*303368	steel, galvanised cross-counterflow	285	22.8

Performance data

Type	Heat exchanger model	Max. door width or height	Max. discharge height or width ¹⁾	Control voltage	Air flow			Heat output				Sound pressure level ³⁾	Sound power level
					Total	Ambient air stream	Warm air	at LPHW 75/65 °C ²⁾		at LPHW 80/40 °C ²⁾			
		[m]	[m]	[V]	[m ³ /h]	[m ³ /h]	[m ³ /h]	[kW]	[°C]	[kW]	[°C]	[dB(A)]	[dB(A)]
*302068	copper/aluminium	3.25	3.5	10	16910	6320	10590	74.5	40.7	---	---	67	83
				8	13610	5090	8520	64.0	42.1	---	---	60	76
				6	9580	3580	6000	50.3	44.7	---	---	51	67
				4	6420	2400	4020	38.1	47.9	---	---	41	57
				2	2980	1120	1860	22.4	55.4	---	---	22	38
*303168	steel, galvanised	3.25	3.5	10	16910	6320	10590	74.5	40.7	---	---	67	83
				8	13610	5090	8520	64.0	42.1	---	---	60	76
				6	9580	3580	6000	50.3	44.7	---	---	51	67
				4	6420	2400	4020	38.1	47.9	---	---	41	57
				2	2980	1120	1860	22.4	55.4	---	---	22	38
*300068	without heat exchanger	3.25	3.5	10	18900	---	---	---	---	---	---	67	83
				8	15780	---	---	---	---	---	---	60	76
				6	10720	---	---	---	---	---	---	51	67
				4	7170	---	---	---	---	---	---	41	57
				2	3330	---	---	---	---	---	---	22	38
*303368	steel, galvanised cross-counter-flow	3.25	3.5	10	14360	5370	8990	---	---	42.0	33.7	67	83
				8	11680	4370	7310	---	---	36.5	34.7	60	76
				6	8380	3130	5250	---	---	29.0	36.2	51	67
				4	5860	2190	3670	---	---	22.7	38.2	41	57
				2	3230	1210	2020	---	---	15.0	41.8	22	38

Use our calculation tools on our website to easily calculate heat outputs and other technical data with just a few clicks!
 ▶ <https://www.kampmann.co.uk/hvac/products/door-air-curtains/protector#Calculate-performance-data>

¹⁾ at low to medium pressure conditions / requirements / circumstances, in conjunction with long outlet nozzle

²⁾ with air intake temperature_i = 20°C, t_u based on warm air stream

³⁾ The sound pressure levels were calculated with an assumed room insulation of 16 dB(A). This corresponds to a distance of 5 m, a room volume of 3000 m³ and a reverberation time of 2.0 s (in accordance with VDI 2081).

ProtecTor

Max. discharge height or width 3.5 m

Model size 40

Version EC fan

Technical drawing (Dimensions in mm)

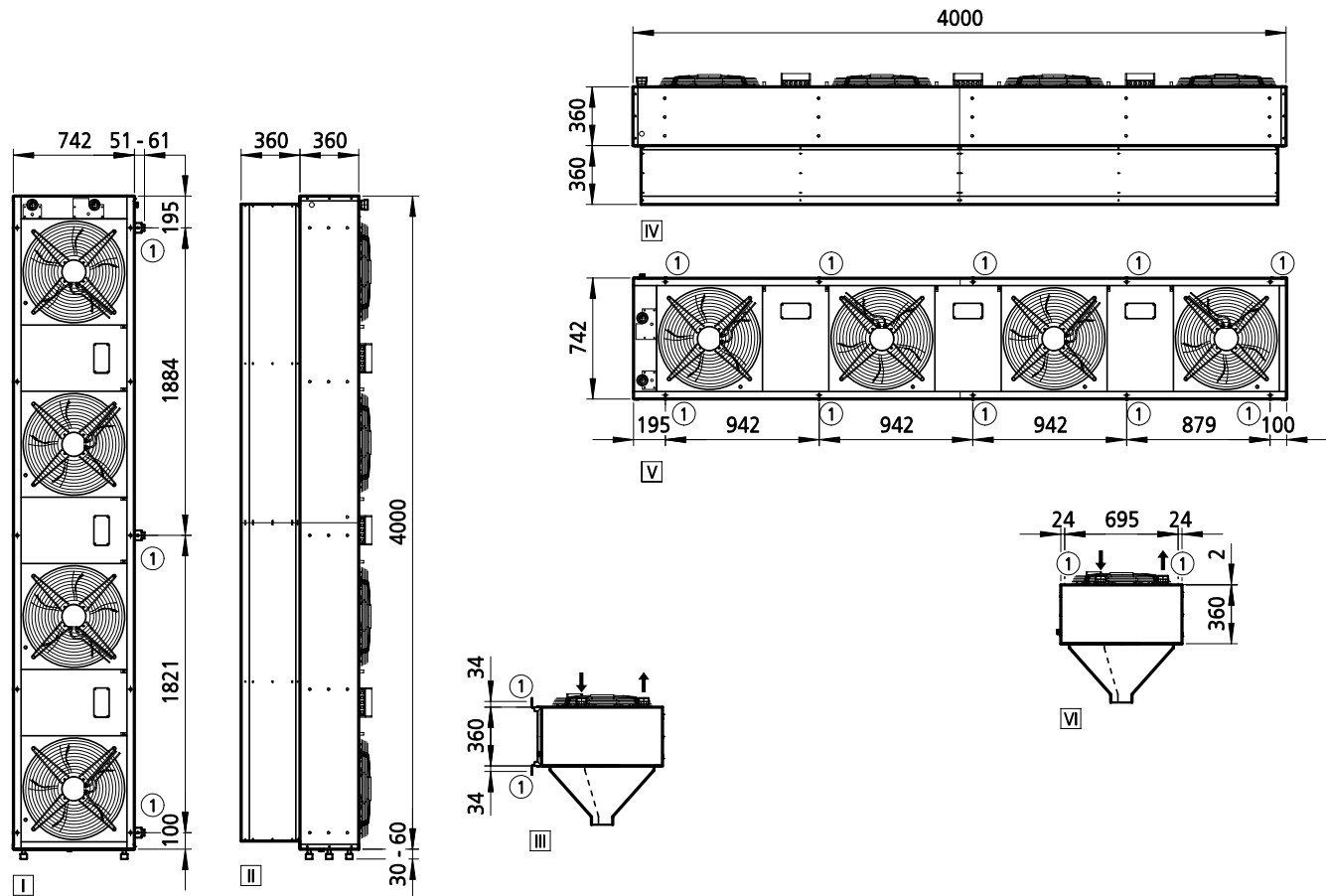

View

- I Side view, standing/upright model
- II Front view, standing/upright model
- III Top view, standing/upright model
- IV Front view, horizontal model
- V Top view, horizontal model
- VI Side view, horizontal model

More information

- ① Fixing point

Specifications

Type	Heat exchanger model	Weight, max. [kg]	Water content [l]
*400068	without heat exchanger	151	---
*402068	copper/aluminium	199	13.9
*403168	steel, galvanised	385	29.3
*403368	steel, galvanised cross-counterflow	380	29.3

Performance data

Type	Heat exchanger model	Max. door width or height	Max. discharge height or width ¹⁾	Control voltage	Air flow			Heat output				Sound pressure level ³⁾	Sound power level
					Total	Ambient air stream	Warm air	at LPHW 75/65 °C ²⁾		at LPHW 80/40 °C ²⁾			
		[m]	[m]	[V]	[m ³ /h]	[m ³ /h]	[m ³ /h]	[kW]	[°C]	[kW]	[°C]	[dB(A)]	[dB(A)]
*402068	copper/aluminium	4.25	3.5	10	22550	8450	14100	99.4	40.7	---	---	68	84
				8	18130	6790	11340	85.5	42.2	---	---	61	77
				6	12770	4790	7980	67.1	44.7	---	---	53	69
				4	8580	3220	5360	50.9	47.9	---	---	43	59
				2	3970	1490	2480	30.0	55.6	---	---	23	39
*403168	steel, galvanised	4.25	3.5	10	22550	8450	14100	99.4	40.7	---	---	68	84
				8	18130	6790	11340	85.5	42.2	---	---	61	77
				6	12770	4790	7980	67.1	44.7	---	---	53	69
				4	8580	3220	5360	50.9	47.9	---	---	43	59
				2	3970	1490	2480	30.0	55.6	---	---	23	39
*400068	without heat exchanger	4.25	3.5	10	25200	---	---	---	---	---	---	68	84
				8	20270	---	---	---	---	---	---	61	77
				6	14280	---	---	---	---	---	---	53	69
				4	9580	---	---	---	---	---	---	43	59
				2	4440	---	---	---	---	---	---	23	39
*403368	steel, galvanised cross-counter-flow	4.25	3.5	10	19150	7180	11970	---	---	56.0	33.8	68	84
				8	15560	5830	9730	---	---	48.6	34.7	61	77
				6	11170	4190	6980	---	---	38.6	36.3	53	69
				4	7810	2930	4880	---	---	30.2	38.2	43	59
				2	4290	1610	2680	---	---	19.9	41.8	23	39

Use our calculation tools on our website to easily calculate heat outputs and other technical data with just a few clicks!
 ▶ <https://www.kampmann.co.uk/hvac/products/door-air-curtains/protector#Calculate-performance-data>

¹⁾ at low to medium pressure conditions / requirements / circumstances, in conjunction with long outlet nozzle

²⁾ with air intake temperature_i = 20°C, t_L based on warm air stream

³⁾ The sound pressure levels were calculated with an assumed room insulation of 16 dB(A). This corresponds to a distance of 5 m, a room volume of 3000 m³ and a reverberation time of 2.0 s (in accordance with VDI 2081).

ProtecTor

Max. discharge height or width 3.5 m

Model size 50

Version EC fan

Technical drawing (Dimensions in mm)

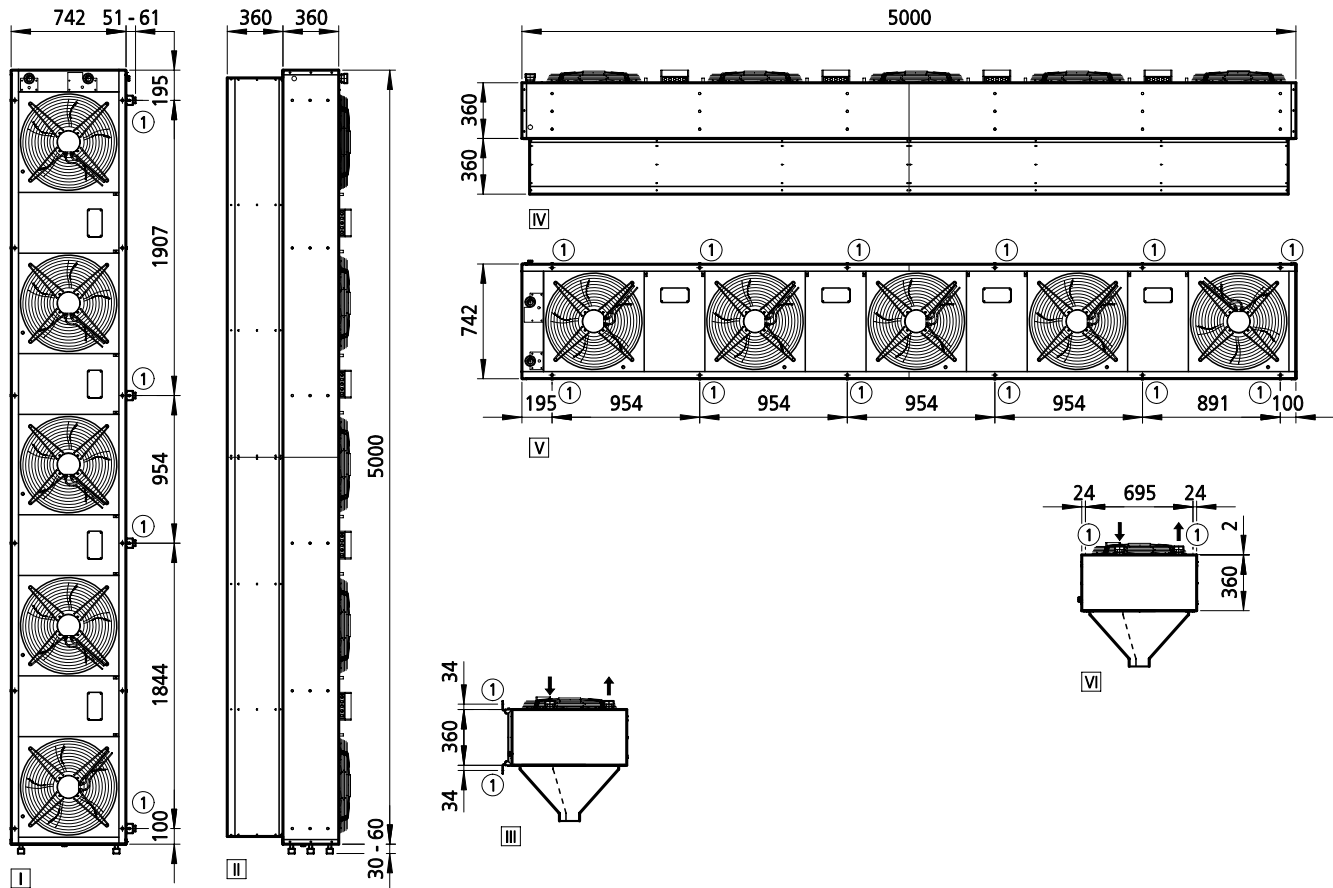

View

- I Side view, standing/upright model
- II Front view, standing/upright model
- III Top view, standing/upright model
- IV Front view, horizontal model
- V Top view, horizontal model
- VI Side view, horizontal model

More information

- ① Fixing point

Specifications

Type	Heat exchanger model	Weight, max. [kg]	Water content [l]
*500068	without heat exchanger	186	---
*502068	copper/aluminium	246	17.1
*503168	steel, galvanised	480	35.8
*503368	steel, galvanised cross-counterflow	473	35.8

Performance data

Type	Heat exchanger model	Max. door width or height	Max. discharge height or width ¹⁾	Control voltage	Air flow			Heat output				Sound pressure level ³⁾	Sound power level	
					Total	Ambient air stream	Warm air	at LPHW 75/65 °C ²⁾		at LPHW 80/40 °C ²⁾				
		[m]	[m]	[V]	[m ³ /h]	[m ³ /h]	[m ³ /h]	[kW]	[°C]	[kW]	[°C]	[dB(A)]	[dB(A)]	
*502068	copper/aluminium	5.25	3.5	10	28190	10570	17620	123.9	40.7	---	---	69	85	
				8	22670	8500	14170	106.6	42.1	---	---	62	78	
				6	15970	5990	9980	83.7	44.7	---	---	54	70	
				4	10710	4020	6690	63.5	47.9	---	---	44	60	
				2	4960	1860	3100	37.3	55.4	---	---	24	40	
*503168	steel, galvanised	5.25	3.5	10	28190	10570	17620	123.9	40.7	---	---	69	85	
				8	22670	8500	14170	106.6	42.1	---	---	62	78	
				6	15970	5990	9980	83.7	44.7	---	---	54	70	
				4	10710	4020	6690	63.5	47.9	---	---	44	60	
				2	4960	1860	3100	37.3	55.4	---	---	24	40	
*500068	without heat exchanger	5.25	3.5	10	31520	---	---	---	---	---	---	69	85	
				8	25350	---	---	---	---	---	---	---	62	78
				6	17840	---	---	---	---	---	---	---	54	70
				4	11960	---	---	---	---	---	---	---	44	60
				2	5540	---	---	---	---	---	---	---	24	40
*503368	steel, galvanised cross-counter-flow	5.25	3.5	10	23940	8980	14960	---	---	69.4	33.6	69	85	
				8	19450	7290	12160	---	---	60.2	34.6	62	78	
				6	13970	5240	8730	---	---	47.9	36.1	54	70	
				4	9770	3670	6100	---	---	37.5	38.1	44	60	
				2	5370	2020	3350	---	---	24.8	41.8	24	40	

Use our calculation tools on our website to easily calculate heat outputs and other technical data with just a few clicks!
 ▶ <https://www.kampmann.co.uk/hvac/products/door-air-curtains/protector#Calculate-performance-data>

¹⁾ at low to medium pressure conditions / requirements / circumstances, in conjunction with long outlet nozzle

²⁾ with air intake temperature_i = 20°C, t_L based on warm air stream

³⁾ The sound pressure levels were calculated with an assumed room insulation of 16 dB(A). This corresponds to a distance of 5 m, a room volume of 3000 m³ and a reverberation time of 2.0 s (in accordance with VDI 2081).

ProtecTor

Max. discharge height or width 4.5 m

Model size 20

Version AC fan

Technical drawing (Dimensions in mm)

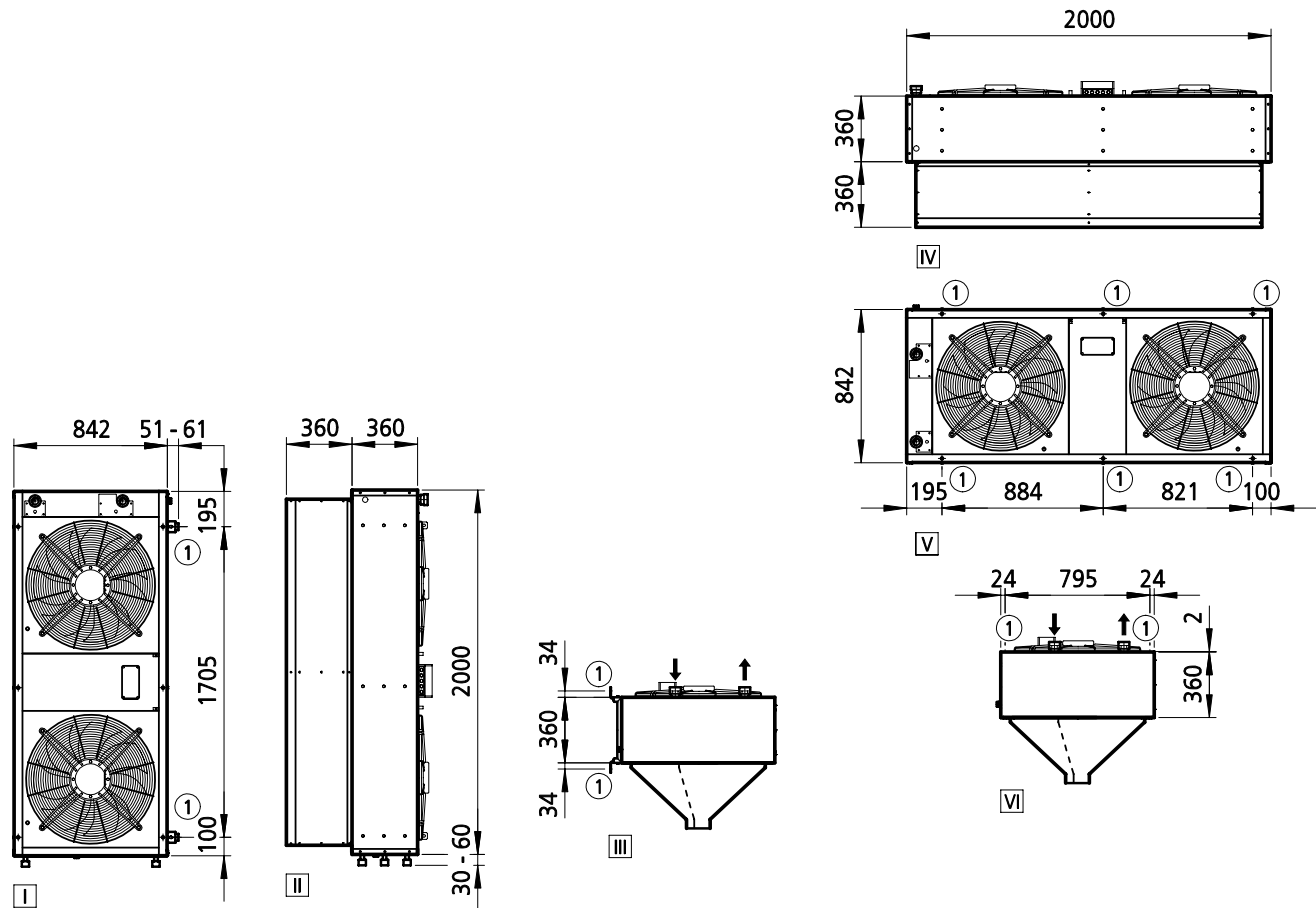

View

- I Side view, standing/upright model
- II Front view, standing/upright model
- III Top view, standing/upright model
- IV Front view, horizontal model
- V Top view, horizontal model
- VI Side view, horizontal model

More information

- ① Fixing point

Specifications

Type	Heat exchanger model	Weight, max. [kg]	Water content [l]
*200076	without heat exchanger	91	---
*202076	copper/aluminium	119	9.5
*203176	steel, galvanised	235	20.0
*203376	steel, galvanised cross-counterflow	228	20.0

Performance data

Type	Heat exchanger model	Max. door width or height	Max. discharge height or width ¹⁾	Switching stage	Air flow			Heat output				Sound pressure level ³⁾	Sound power level
					Total	Ambient air stream	Warm air	at LPHW 75/65 °C ²⁾		at LPHW 80/40 °C ²⁾			
		[m]	[m]		[m ³ /h]	[m ³ /h]	[m ³ /h]	[kW]	[°C]	[kW]	[°C]	[dB(A)]	[dB(A)]
*202076	copper/aluminium	2.25	4.5	2	14350	5360	8990	66.7	41.8	---	---	64	80
				1	11950	4430	7250	53.0	40.7	---	---	60	76
*203176	steel, galvanised	2.25	4.5	2	14350	5360	8990	66.7	41.8	---	---	64	80
				1	11950	4430	7250	53.0	40.7	---	---	60	76
*200076	without heat exchanger	2.25	4.5	2	16050	–	–	---	---	---	---	64	80
				1	13250	–	–	---	---	---	---	60	76
*203376	steel, galvanised cross-counter-flow	2.25	4.5	2	14350	5360	8990	---	---	48.6	35.9	64	80
				1	11950	4430	7250	---	---	42.2	37.1	60	76

Use our calculation tools on our website to easily calculate heat outputs and other technical data with just a few clicks!

► <https://www.kampmann.co.uk/hvac/products/door-air-curtains/protector#Calculate-performance-data>

¹⁾ at low to medium pressure conditions / requirements / circumstances, in conjunction with long outlet nozzle

²⁾ with air intake temperature_i = 20°C, t_z based on warm air stream

³⁾ The sound pressure levels were calculated with an assumed room insulation of 16 dB(A). This corresponds to a distance of 5 m, a room volume of 3000 m³ and a reverberation time of 2.0 s (in accordance with VDI 2081).

ProtecTor

Max. discharge height or width 4.5 m

Model size 30

Version AC fan

Technical drawing (Dimensions in mm)

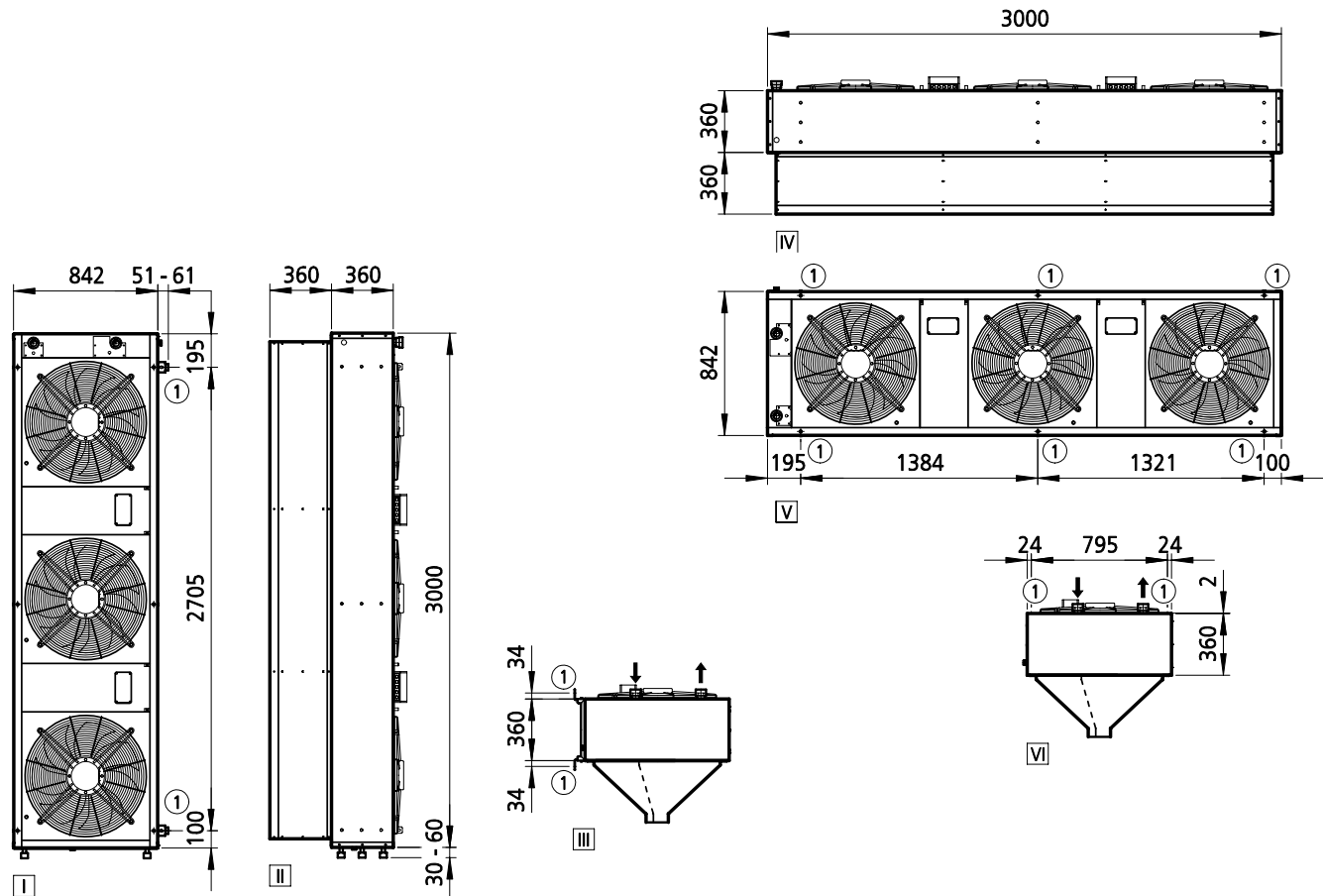

- View**
- I Side view, standing/upright model
 - II Front view, standing/upright model
 - III Top view, standing/upright model
 - IV Front view, horizontal model
 - V Top view, horizontal model
 - VI Side view, horizontal model

More information

- ① Fixing point

Specifications

Type	Heat exchanger model	Weight, max. [kg]	Water content [l]
*300076	without heat exchanger	124	---
*302076	copper/aluminium	168	13.4
*303176	steel, galvanised	343	28.1
*303376	steel, galvanised cross-counterflow	356	28.1

Performance data

Type	Heat exchanger model	Max. door width or height	Max. discharge height or width ¹⁾	Switching stage	Air flow			Heat output				Sound pressure level ³⁾	Sound power level
					Total	Ambient air stream	Warm air	at LPHW 75/65 °C ²⁾		at LPHW 80/40 °C ²⁾			
		[m]	[m]		[m ³ /h]	[m ³ /h]	[m ³ /h]	[kW]	[°C]	[kW]	[°C]	[dB(A)]	[dB(A)]
*302076	copper/aluminium	3.25	4.5	2	21500	8030	13470	100.3	41.9	---	---	66	82
				1	17900	6640	11260	79.5	40.8	---	---	62	78
*303176	steel, galvanised	3.25	4.5	2	21500	8030	13470	100.3	41.9	---	---	66	82
				1	17900	6640	11260	79.5	40.8	---	---	62	78
*300076	without heat exchanger	3.25	4.5	2	24100	–	–	---	---	---	---	66	82
				1	19900	–	–	---	---	---	---	62	78
*303376	steel, galvanised cross-counter-flow	3.25	4.5	2	21500	8030	13470	---	---	72.4	35.8	66	82
				1	17900	6640	11260	---	---	65.8	37.2	62	78

Use our calculation tools on our website to easily calculate heat outputs and other technical data with just a few clicks!
 ▶ <https://www.kampmann.co.uk/hvac/products/door-air-curtains/protector#Calculate-performance-data>

¹⁾ at low to medium pressure conditions / requirements / circumstances, in conjunction with long outlet nozzle

²⁾ with air intake temperature_i = 20°C, t_z based on warm air stream

³⁾ The sound pressure levels were calculated with an assumed room insulation of 16 dB(A). This corresponds to a distance of 5 m, a room volume of 3000 m³ and a reverberation time of 2.0 s (in accordance with VDI 2081).

ProtecTor

Max. discharge height or width 4.5 m

Model size 40

Version AC fan

Technical drawing (Dimensions in mm)

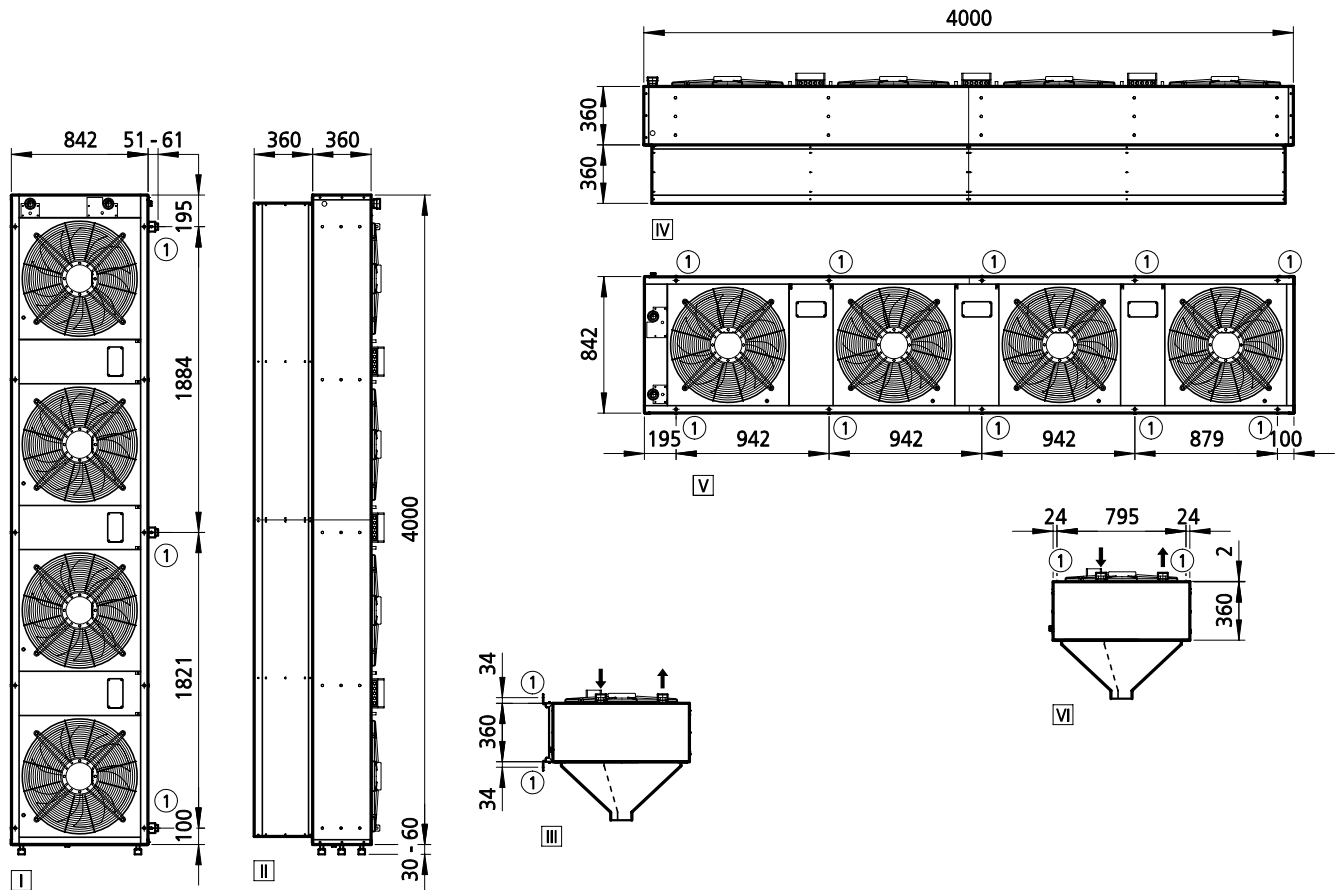

View

- I Side view, standing/upright model
- II Front view, standing/upright model
- III Top view, standing/upright model
- IV Front view, horizontal model
- V Top view, horizontal model
- VI Side view, horizontal model

More information

- ① Fixing point

Specifications

Type	Heat exchanger model	Weight, max. [kg]	Water content [l]
*400076	without heat exchanger	209	---
*402076	copper/aluminium	223	17.2
*403176	steel, galvanised	458	36.2
*403376	steel, galvanised cross-counterflow	450	36.2

Performance data

Type	Heat exchanger model	Max. door width or height	Max. discharge height or width ¹⁾	Switching stage	Air flow			Heat output				Sound pressure level ³⁾	Sound power level
					Total	Ambient air stream	Warm air	at LPHW 75/65 °C ²⁾		at LPHW 80/40 °C ²⁾			
		[m]	[m]		[m ³ /h]	[m ³ /h]	[m ³ /h]	[kW]	[°C]	[kW]	[°C]	[dB(A)]	[dB(A)]
*402076	copper/aluminium	4.25	4.5	2	28600	10700	17900	133.8	42.0	---	---	67	83
				1	23900	8870	15030	106.0	40.7	---	---	63	79
*403176	steel, galvanised	4.25	4.5	2	28600	10700	17900	133.8	42.0	---	---	67	83
				1	23900	8870	15030	106.0	40.7	---	---	63	79
*400076	without heat exchanger	4.25	4.5	2	32100	–	–	---	---	---	---	67	83
				1	26600	–	–	---	---	---	---	63	79
*403376	steel, galvanised cross-counter-flow	4.25	4.5	2	28600	10700	17900	---	---	96.8	35.9	67	83
				1	23900	8870	15030	---	---	87.4	37.1	63	79

Use our calculation tools on our website to easily calculate heat outputs and other technical data with just a few clicks!

▶ <https://www.kampmann.co.uk/hvac/products/door-air-curtains/protector#Calculate-performance-data>

¹⁾ at low to medium pressure conditions / requirements / circumstances, in conjunction with long outlet nozzle

²⁾ with air intake temperature_i = 20°C, t_z based on warm air stream

³⁾ The sound pressure levels were calculated with an assumed room insulation of 16 dB(A). This corresponds to a distance of 5 m, a room volume of 3000 m³ and a reverberation time of 2.0 s (in accordance with VDI 2081).

ProtecTor

Max. discharge height or width 4.5 m

Model size 50

Version AC fan

Technical drawing (Dimensions in mm)

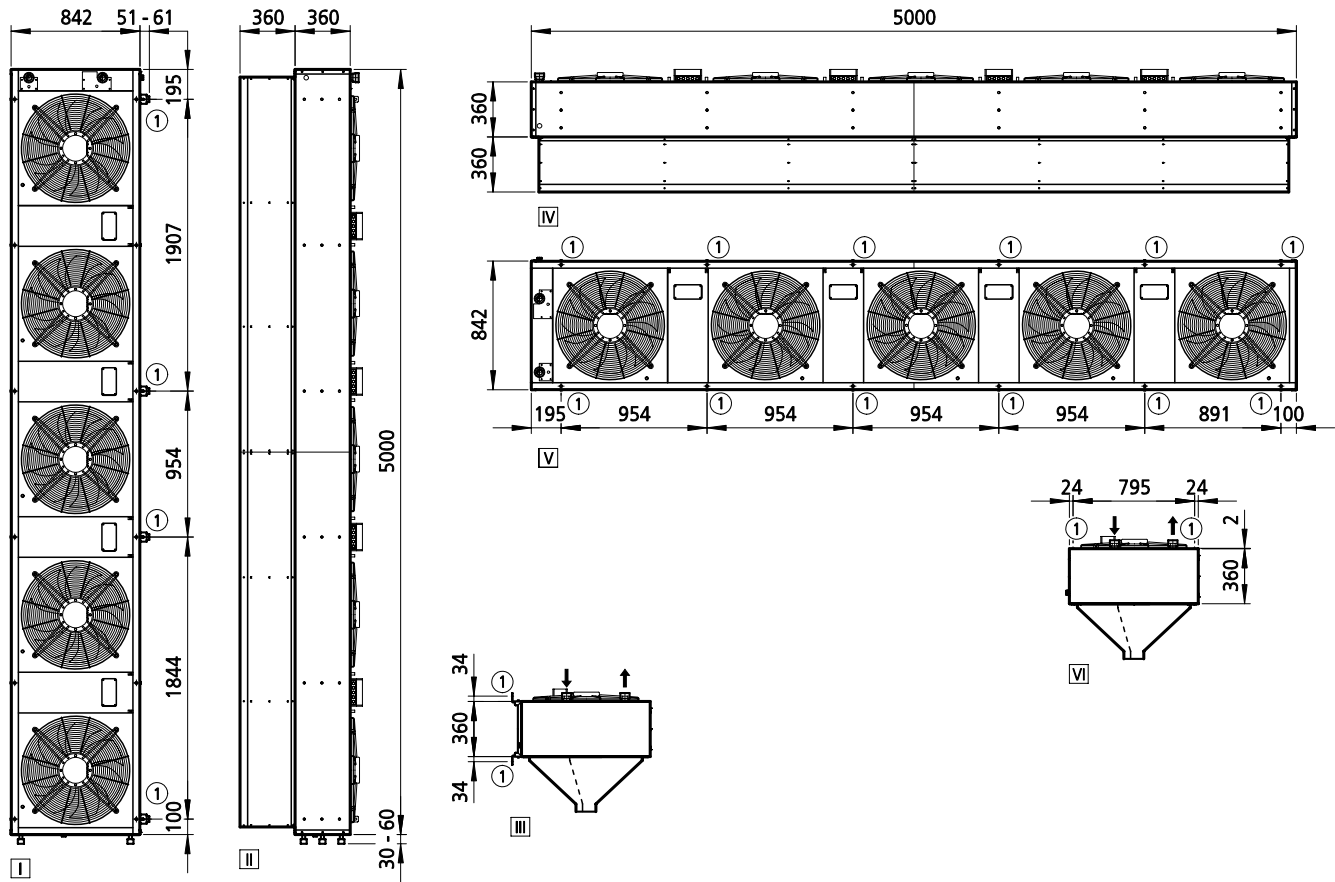

- View**
- I Side view, standing/upright model
 - II Front view, standing/upright model
 - III Top view, standing/upright model
 - IV Front view, horizontal model
 - V Top view, horizontal model
 - VI Side view, horizontal model

More information

- ① Fixing point

Specifications

Type	Heat exchanger model	Weight, max. [kg]	Water content [l]
*500076	without heat exchanger	202	---
*502076	copper/aluminium	276	21.2
*503176	steel, galvanised	572	44.3
*503376	steel, galvanised cross-counterflow	560	44.3

Performance data

Type	Heat exchanger model	Max. door width or height	Max. discharge height or width ¹⁾	Switching stage	Air flow			Heat output				Sound pressure level ³⁾	Sound power level
					Total	Ambient air stream	Warm air	at LPHW 75/65 °C ²⁾		at LPHW 80/40 °C ²⁾			
		[m]	[m]		[m ³ /h]	[m ³ /h]	[m ³ /h]	[kW]	[°C]	[kW]	[°C]	[dB(A)]	[dB(A)]
*502076	copper/aluminium	5.25	4.5	2	35800	13350	22450	167.2	41.9	---	---	68	84
				1	29800	11030	18770	132.5	40.8	---	---	64	80
*503176	steel, galvanised	5.25	4.5	2	35800	13350	22450	167.2	41.9	---	---	68	84
				1	29800	11030	18770	132.5	40.8	---	---	64	80
*500076	without heat exchanger	5.25	4.5	2	40050	–	–	---	---	---	---	68	84
				1	33090	–	–	---	---	---	---	64	80
*503376	steel, galvanised cross-counter-flow	5.25	4.5	2	35800	13350	22450	---	---	120.6	35.8	68	84
				1	29800	11030	18770	---	---	109.8	37.2	64	80

Use our calculation tools on our website to easily calculate heat outputs and other technical data with just a few clicks!
 ▶ <https://www.kampmann.co.uk/hvac/products/door-air-curtains/protector#Calculate-performance-data>

¹⁾ at low to medium pressure conditions / requirements / circumstances, in conjunction with long outlet nozzle

²⁾ with air intake temperature_i = 20°C, t_z based on warm air stream

³⁾ The sound pressure levels were calculated with an assumed room insulation of 16 dB(A). This corresponds to a distance of 5 m, a room volume of 3000 m³ and a reverberation time of 2.0 s (in accordance with VDI 2081).

ProtecTor

Max. discharge height or width 4.5 m

Model size 20

Version EC fan

Technical drawing (Dimensions in mm)

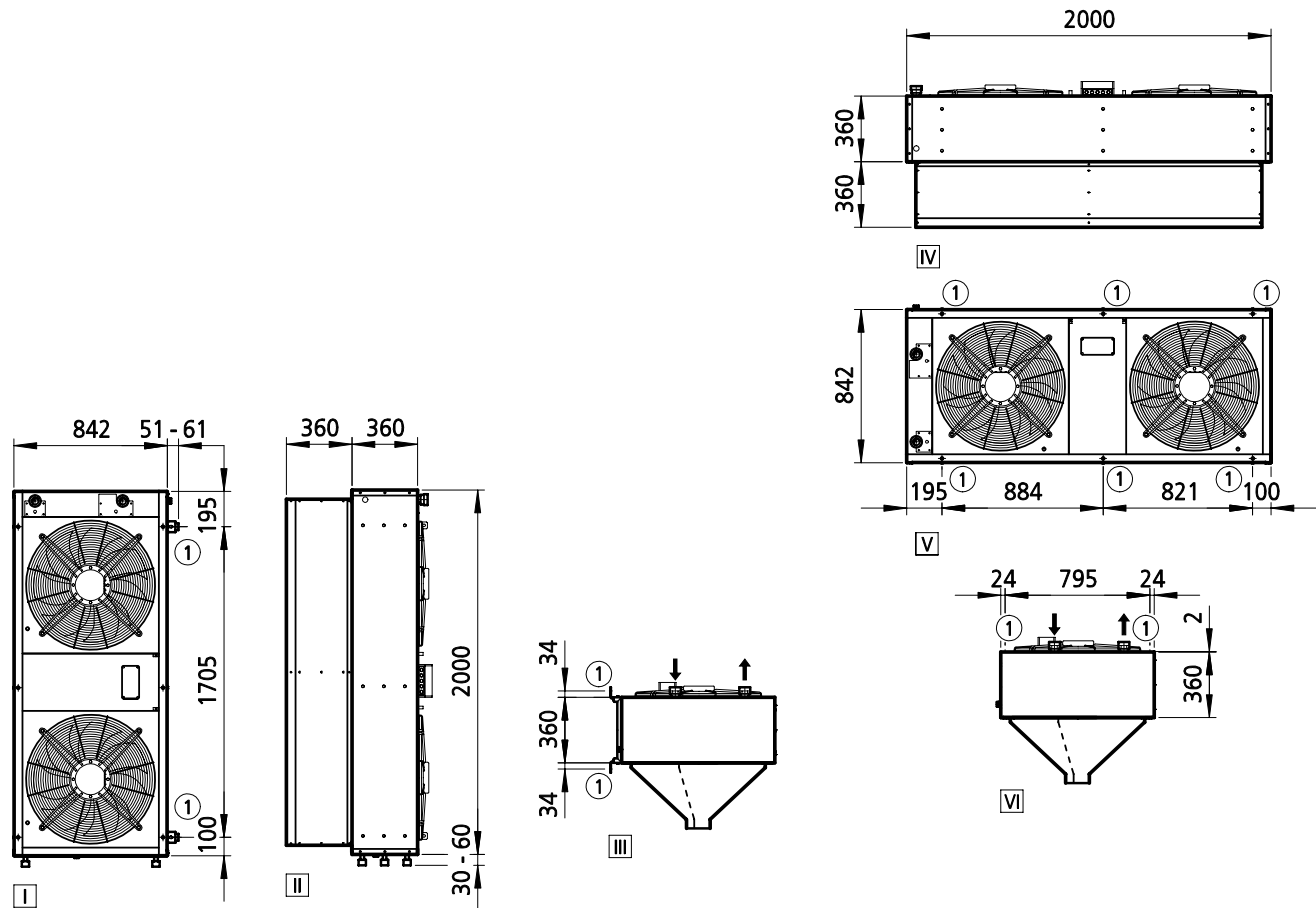

View

- I Side view, standing/upright model
- II Front view, standing/upright model
- III Top view, standing/upright model
- IV Front view, horizontal model
- V Top view, horizontal model
- VI Side view, horizontal model

More information

- ① Fixing point

Specifications

Type	Heat exchanger model	Weight, max. [kg]	Water content [l]
*200078	without heat exchanger	96	---
*202078	copper/aluminium	123	9.5
*203178	steel, galvanised	240	20.0
*203378	steel, galvanised cross-counterflow	233	20.0

Performance data

Type	Heat exchanger model	Max. door width or height	Max. discharge height or width ¹⁾	Control voltage	Air flow			Heat output				Sound pressure level ³⁾	Sound power level
					Total	Ambient air stream	Warm air	at LPHW 75/65 °C ²⁾		at LPHW 80/40 °C ²⁾			
		[m]	[m]	[V]	[m ³ /h]	[m ³ /h]	[m ³ /h]	[kW]	[°C]	[kW]	[°C]	[dB(A)]	[dB(A)]
*202078	copper/aluminium	2.25	4.5	10	15820	5910	9910	71.3	41.2	---	---	66	82
				8	13450	5020	8430	63.8	42.3	---	---	63	79
				6	10130	3780	6350	52.5	44.3	---	---	57	73
				4	6690	2500	4190	39.4	47.7	---	---	48	64
				2	2950	1100	1850	22.4	55.6	---	---	33	49
*203178	steel, galvanised	2.25	4.5	10	15820	5910	9910	71.3	41.2	---	---	66	82
				8	13450	5020	8430	63.8	42.3	---	---	63	79
				6	10130	3780	6350	52.5	44.3	---	---	57	73
				4	6690	2500	4190	39.4	47.7	---	---	48	64
				2	2950	1100	1850	22.4	55.6	---	---	33	49
*200078	without heat exchanger	2.25	4.5	10	17690	---	---	---	---	---	---	66	82
				8	15050	---	---	---	---	---	---	63	79
				6	11320	---	---	---	---	---	---	57	73
				4	7470	---	---	---	---	---	---	48	64
				2	3300	---	---	---	---	---	---	33	49
*203378	steel, galvanised cross-counter-flow	2.25	4.5	10	14540	5430	9110	---	---	49.1	35.9	66	82
				8	12440	4640	7800	---	---	44.1	36.6	63	79
				6	9460	3530	5930	---	---	36.4	38.1	57	73
				4	6430	2400	4030	---	---	29.9	41.8	48	64
				2	3140	1170	1970	---	---	17.1	45.5	33	49

Use our calculation tools on our website to easily calculate heat outputs and other technical data with just a few clicks!
 ▶ <https://www.kampmann.co.uk/hvac/products/door-air-curtains/protector#Calculate-performance-data>

¹⁾ at low to medium pressure conditions / requirements / circumstances, in conjunction with long outlet nozzle

²⁾ with air intake temperature_i = 20°C, t_L based on warm air stream

³⁾ The sound pressure levels were calculated with an assumed room insulation of 16 dB(A). This corresponds to a distance of 5 m, a room volume of 3000 m³ and a reverberation time of 2.0 s (in accordance with VDI 2081).

ProtecTor

Max. discharge height or width 4.5 m

Model size 30

Version EC fan

Technical drawing (Dimensions in mm)

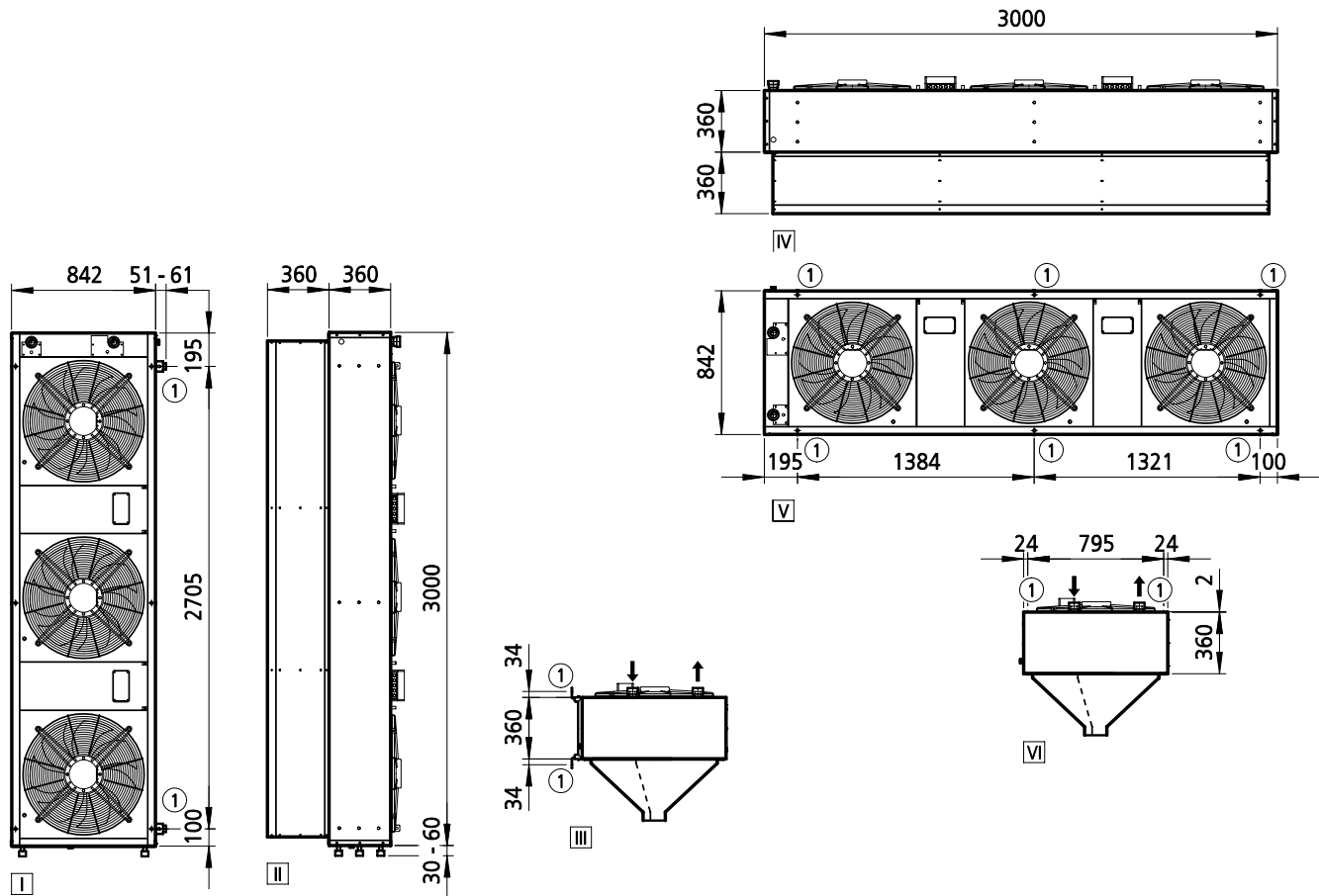

View

- I Side view, standing/upright model
- II Front view, standing/upright model
- III Top view, standing/upright model
- IV Front view, horizontal model
- V Top view, horizontal model
- VI Side view, horizontal model

More information

- ① Fixing point

Specifications

Type	Heat exchanger model	Weight, max. [kg]	Water content [l]
*300078	without heat exchanger	131	---
*302078	copper/aluminium	175	13.4
*303178	steel, galvanised	351	28.1
*303378	steel, galvanised cross-counterflow	363	28.1

Performance data

Type	Heat exchanger model	Max. door width or height	Max. discharge height or width ¹⁾	Control voltage	Air flow			Heat output				Sound pressure level ³⁾	Sound power level	
					Total	Ambient air stream	Warm air	at LPHW 75/65 °C ²⁾		at LPHW 80/40 °C ²⁾				
		[m]	[m]	[V]	[m ³ /h]	[m ³ /h]	[m ³ /h]	[kW]	[°C]	[kW]	[°C]	[dB(A)]	[dB(A)]	
*302078	copper/aluminium	3.25	4.5	10	23720	8860	14860	107.3	41.2	---	---	68	84	
				8	20210	7550	12660	96.1	42.3	---	---	64	80	
				6	15180	5670	9510	78.8	44.4	---	---	58	74	
				4	10020	3740	6280	59.2	47.7	---	---	49	65	
				2	4430	1650	2780	33.7	55.7	---	---	35	51	
*303178	steel, galvanised	3.25	4.5	10	23720	8860	14860	107.3	41.2	---	---	68	84	
				8	20210	7550	12660	96.1	42.3	---	---	64	80	
				6	15180	5670	9510	78.8	44.4	---	---	58	74	
				4	10020	3740	6280	59.2	47.7	---	---	49	65	
				2	4430	1650	2780	33.7	55.7	---	---	35	51	
*300078	without heat exchanger	3.25	4.5	10	26520	---	---	---	---	---	---	68	84	
				8	22580	---	---	---	---	---	---	---	64	80
				6	16960	---	---	---	---	---	---	---	58	74
				4	11200	---	---	---	---	---	---	---	49	65
				2	4960	---	---	---	---	---	---	---	35	51
*303378	steel, galvanised cross-counter-flow	3.25	4.5	10	21810	8150	13660	---	---	73.1	35.7	68	84	
				8	18680	6980	11700	---	---	65.7	36.5	64	80	
				6	14190	5300	8890	---	---	54.4	38.0	58	74	
				4	9640	3600	6040	---	---	41.7	40.3	49	65	
				2	4700	1750	2950	---	---	25.4	45.3	35	51	

Use our calculation tools on our website to easily calculate heat outputs and other technical data with just a few clicks!
 ▶ <https://www.kampmann.co.uk/hvac/products/door-air-curtains/protector#Calculate-performance-data>

¹⁾ at low to medium pressure conditions / requirements / circumstances, in conjunction with long outlet nozzle

²⁾ with air intake temperature_i = 20°C, t_L based on warm air stream

³⁾ The sound pressure levels were calculated with an assumed room insulation of 16 dB(A). This corresponds to a distance of 5 m, a room volume of 3000 m³ and a reverberation time of 2.0 s (in accordance with VDI 2081).

ProtecTor

Max. discharge height or width 4.5 m

Model size 40

Version EC fan

Technical drawing (Dimensions in mm)

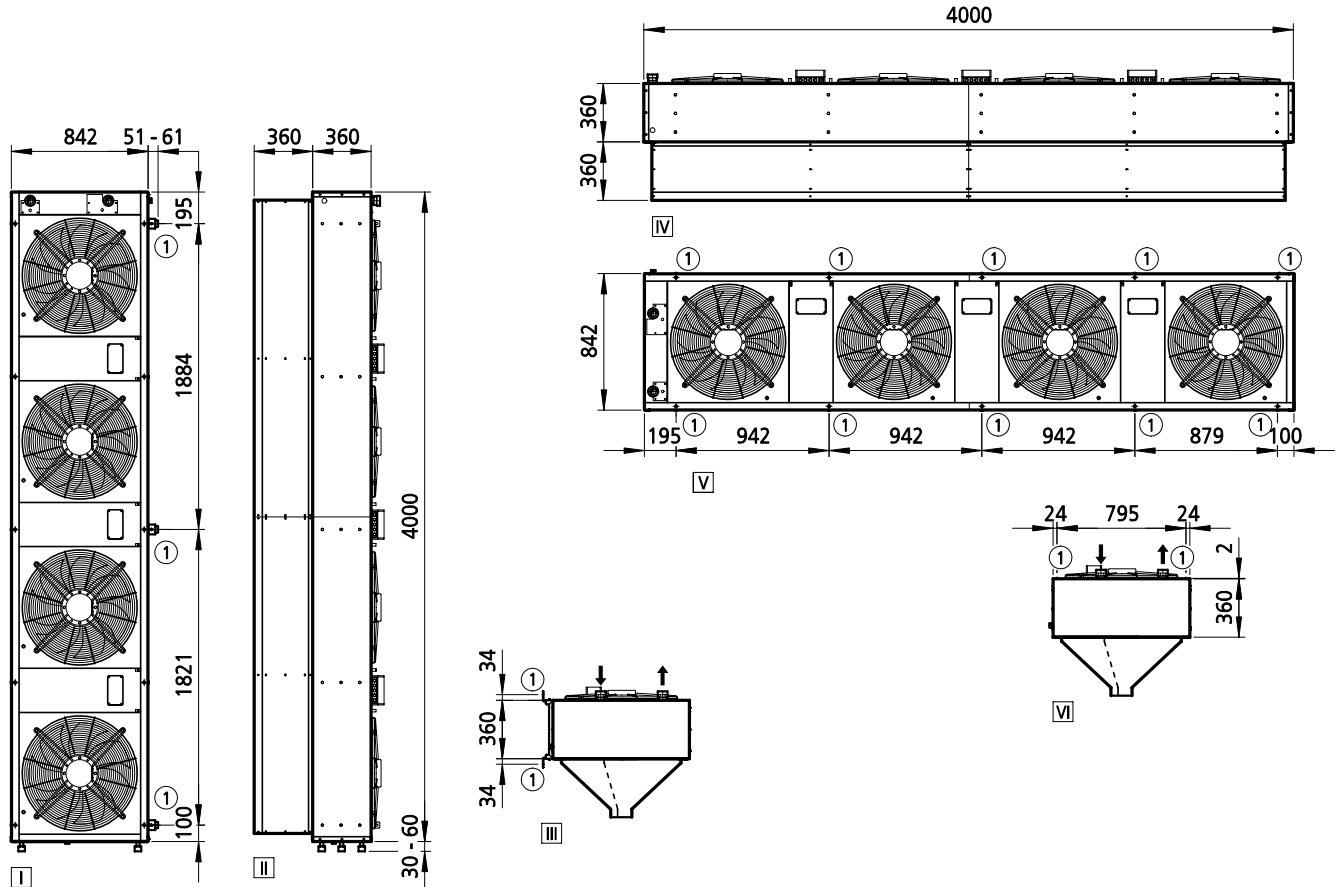

View

- I Side view, standing/upright model
- II Front view, standing/upright model
- III Top view, standing/upright model
- IV Front view, horizontal model
- V Top view, horizontal model
- VI Side view, horizontal model

More information

- ① Fixing point

Specifications

Type	Heat exchanger model	Weight, max. [kg]	Water content [l]
*400078	without heat exchanger	173	---
*402078	copper/aluminium	232	17.2
*403178	steel, galvanised	467	36.2
*403378	steel, galvanised cross-counterflow	459	36.2

Performance data

Type	Heat exchanger model	Max. door width or height	Max. discharge height or width ¹⁾	Control voltage	Air flow			Heat output				Sound pressure level ³⁾	Sound power level	
					Total	Ambient air stream	Warm air	at LPHW 75/65 °C ²⁾		at LPHW 80/40 °C ²⁾				
		[m]	[m]	[V]	[m ³ /h]	[m ³ /h]	[m ³ /h]	[kW]	[°C]	[kW]	[°C]	[dB(A)]	[dB(A)]	
*402078	copper/aluminium	4.25	4.5	10	31640	11840	19800	143.5	41.3	---	---	69	85	
				8	26940	10080	16860	128.4	42.4	---	---	66	82	
				6	20240	7580	12660	105.4	44.5	---	---	60	76	
				4	13360	5000	8360	79.1	47.8	---	---	51	67	
				2	5910	2210	3700	45.1	55.9	---	---	36	52	
*403178	steel, galvanised	4.25	4.5	10	31640	11840	19800	143.5	41.3	---	---	69	85	
				8	26940	10080	16860	128.4	42.4	---	---	66	82	
				6	20240	7580	12660	105.4	44.5	---	---	60	76	
				4	13360	5000	8360	79.1	47.8	---	---	51	67	
				2	5910	2210	3700	45.1	55.9	---	---	36	52	
*400078	without heat exchanger	4.25	4.5	10	35370	---	---	---	---	---	---	69	85	
				8	30110	---	---	---	---	---	---	---	66	82
				6	22630	---	---	---	---	---	---	60	76	
				4	940	---	---	---	---	---	---	51	67	
				2	6600	---	---	---	---	---	---	36	52	
*403378	steel, galvanised cross-counter-flow	4.25	4.5	10	29080	10880	18200	---	---	97.9	35.8	69	85	
				8	24890	9310	15580	---	---	88.0	36.6	66	82	
				6	18920	7080	11840	---	---	72.8	38.1	60	76	
				4	12850	4810	8040	---	---	55.7	40.4	51	67	
				2	6280	2350	3930	---	---	34.0	45.4	36	52	

Use our calculation tools on our website to easily calculate heat outputs and other technical data with just a few clicks!
 ▶ <https://www.kampmann.co.uk/hvac/products/door-air-curtains/protector#Calculate-performance-data>

¹⁾ at low to medium pressure conditions / requirements / circumstances, in conjunction with long outlet nozzle

²⁾ with air intake temperature_i = 20°C, t_L based on warm air stream

³⁾ The sound pressure levels were calculated with an assumed room insulation of 16 dB(A). This corresponds to a distance of 5 m, a room volume of 3000 m³ and a reverberation time of 2.0 s (in accordance with VDI 2081).

ProtecTor

Max. discharge height or width 4.5 m

Model size 50

Version EC fan

Technical drawing (Dimensions in mm)

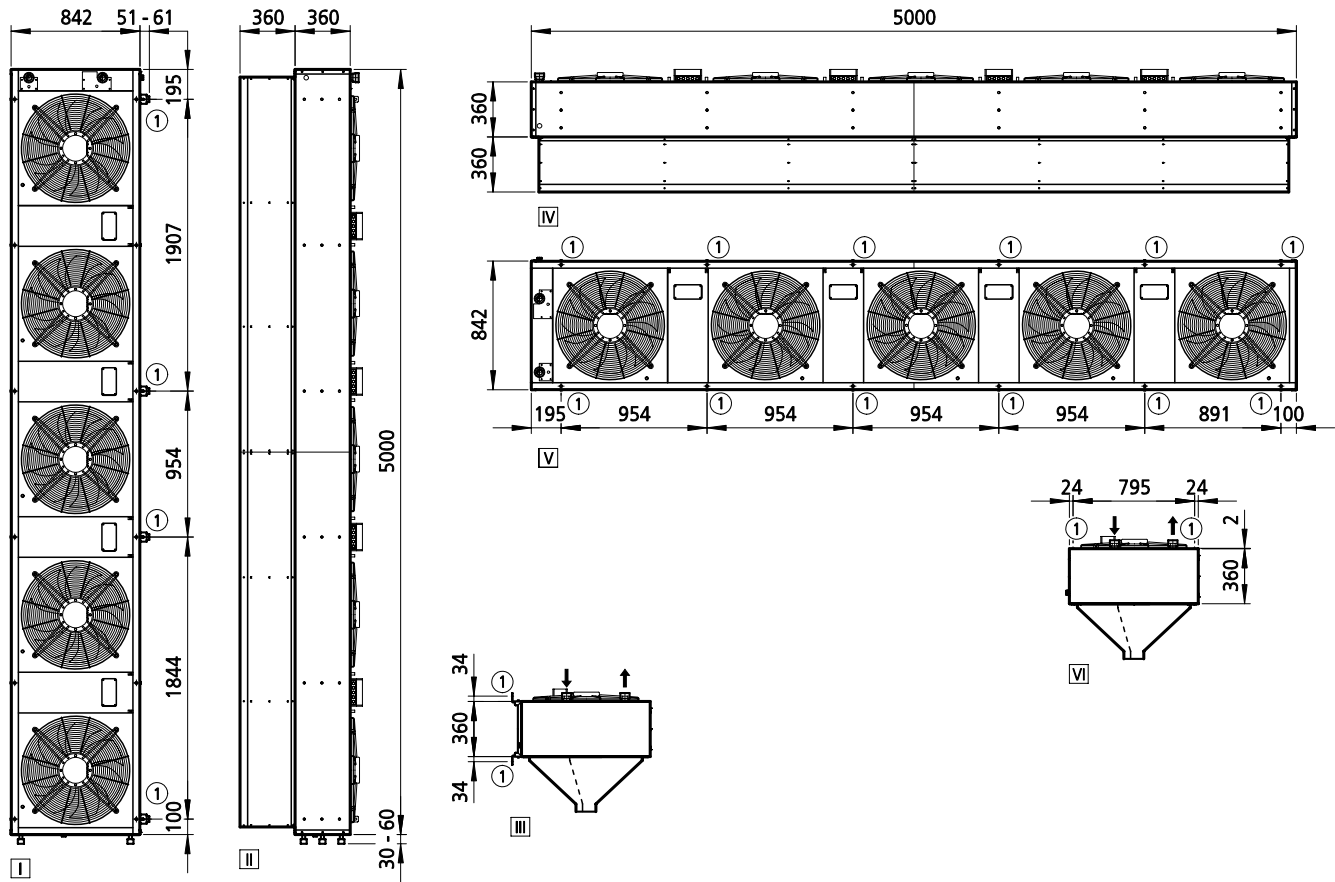

View

- I Side view, standing/upright model
- II Front view, standing/upright model
- III Top view, standing/upright model
- IV Front view, horizontal model
- V Top view, horizontal model
- VI Side view, horizontal model

More information

- ① Fixing point

Specifications

Type	Heat exchanger model	Weight, max. [kg]	Water content [l]
*500078	without heat exchanger	213	---
*502078	copper/aluminium	287	21.2
*503178	steel, galvanised	582	44.3
*503378	steel, galvanised cross-counterflow	571	44.3

Performance data

Type	Heat exchanger model	Max. door width or height	Max. discharge height or width ¹⁾	Control voltage	Air flow			Heat output				Sound pressure level ³⁾	Sound power level	
					Total	Ambient air stream	Warm air	at LPHW 75/65 °C ²⁾		at LPHW 80/40 °C ²⁾				
		[m]	[m]	[V]	[m ³ /h]	[m ³ /h]	[m ³ /h]	[kW]	[°C]	[kW]	[°C]	[dB(A)]	[dB(A)]	
*502078	copper/aluminium	5.25	4.5	10	39530	14740	24790	179.0	41.2	---	---	70	86	
				8	33660	12550	21110	160.3	42.3	---	---	67	83	
				6	25310	9440	15870	131.6	44.4	---	---	61	77	
				4	11100	630	10470	98.8	47.8	---	---	52	68	
				2	7380	2750	4630	56.2	55.7	---	---	37	53	
*503178	steel, galvanised	5.25	4.5	10	39530	14740	24790	179.0	41.2	---	---	70	86	
				8	33660	12550	21110	160.3	42.3	---	---	67	83	
				6	25310	9440	15870	131.6	44.4	---	---	61	77	
				4	11100	630	10470	98.8	47.8	---	---	52	68	
				2	7380	2750	4630	56.2	55.7	---	---	37	53	
*500078	without heat exchanger	5.25	4.5	10	44190	---	---	---	---	---	---	70	86	
				8	37620	---	---	---	---	---	---	---	67	83
				6	28290	---	---	---	---	---	---	---	61	77
				4	12420	---	---	---	---	---	---	---	52	68
				2	8250	---	---	---	---	---	---	---	37	53
*503378	steel, galvanised cross-counter-flow	5.25	4.5	10	36360	13560	22800	---	---	121.9	35.7	70	86	
				8	31110	11600	19510	---	---	109.5	36.5	67	83	
				6	23650	8820	14830	---	---	90.6	38.0	61	77	
				4	16050	5980	10070	---	---	69.3	40.2	52	68	
				2	7840	2920	4920	---	---	42.3	45.3	37	53	

Use our calculation tools on our website to easily calculate heat outputs and other technical data with just a few clicks!
 ▶ <https://www.kampmann.co.uk/hvac/products/door-air-curtains/protector#Calculate-performance-data>

¹⁾ at low to medium pressure conditions / requirements / circumstances, in conjunction with long outlet nozzle

²⁾ with air intake temperature_i = 20°C, t_L based on warm air stream

³⁾ The sound pressure levels were calculated with an assumed room insulation of 16 dB(A). This corresponds to a distance of 5 m, a room volume of 3000 m³ and a reverberation time of 2.0 s (in accordance with VDI 2081).

03 ▶ Design information



Information on planning and design

Selection and size of door air curtains

When positioned over the door (horizontal arrangement), the equipment needs to be installed in such a way that the air outlet is positioned as closely as possible to the door opening.

With horizontal and vertical gaps of more than 500 mm between the door opening and outlet nozzle, select the next model length up or provide for side panelling similar to a corridor.

Application limits

Extremely poor operating conditions, such as:

- ▶ strong underpressure in the room, e.g. produced by mechanical ventilation without the supply of outside air,
- ▶ extremely adverse weather conditions with high wind speeds in an unprotected position,
- ▶ several openings to the outside, especially if they are positioned opposite each other,

can impair the effective screening effect of the door air curtains. Additional measures, may need to be put in place, to compensate for the pressure in the room. When designing doorway entrances, note that it may be necessary to close the doors when the building is occupied. Provide for units with higher air outputs and heat outputs should doorways need to remain open in large warehouses, even in the event of unfavourable or extreme weather. They have to be in a position to heat up the large volumes of cold air, which can penetrate under certain circumstances.

Layout

When positioned over the door (horizontal arrangement), the equipment needs to be installed in such a way that the air outlet is positioned as closely as possible to the door opening. Provide a gap of 320 mm above the motor guard, both with horizontal and standing units.

Ceiling-mounted

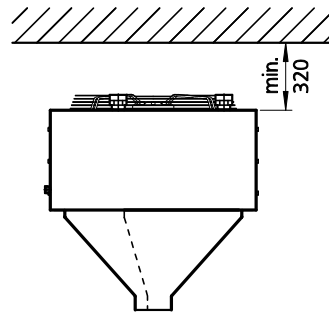

Example: Ceiling-mounted horizontal unit

Max. air discharge height or width

The maximum air discharge height and/or width comes from the maximum penetration depth of the air stream in the doorway area. The maximum air discharge height and width is dependent on

- ▶ the fan size of the unit
- ▶ the air discharge nozzle for the air outlet

The maximum mounting heights given in the Technical data **on pages 14 – 49** apply to free-blowing operation including discharge nozzle at maximum fan speed.

Discharge-side accessories

The air discharge heights and/or widths stated in the technical data on pages 14 – 45 only apply in conjunction with the discharge nozzle fitted.

When using the short discharge nozzle, note that it can reduce the air discharge height or width by up to 1.0 metre.

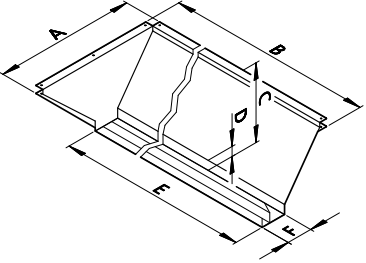
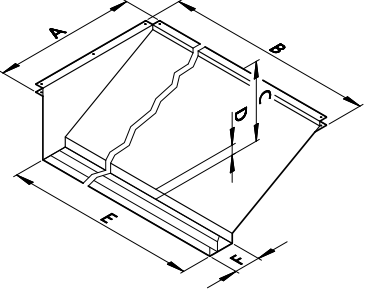
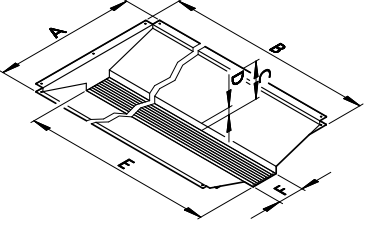
Figure	Article	Properties						
Discharge-side accessories								
	Discharge nozzle, long, medium	Discharge nozzle, long, arranged centrally for ProtecTor door air curtains, suitable for use up to an air discharge height of 3.5 metres						
		A	B	C	D	E	F	
		Size 20	715	1978	360	50	1900	130
		Size 30	715	2978	360	50	2900	130
		Size 40	715	3978	360	50	3900	130
		Size 50	715	4978	360	50	4900	130
		Discharge nozzle, long, arranged centrally for ProtecTor door air curtains, suitable for use up to an air discharge height of 4.5 metres						
		A	B	C	D	E	F	
		Size 20	815	1978	360	50	1900	130
		Size 30	815	2978	360	50	2900	130
Size 40	815	3978	360	50	3900	130		
Size 50	815	4978	360	50	4900	130		
	Discharge nozzle, long, monodirectional	Discharge nozzle, long monodirectional arrangement, for ProtecTor door air curtains, suitable for use up to an air discharge height of 3.5 metres						
		A	B	C	D	E	F	
		Size 20	715	1978	360	50	1900	130
		Size 30	715	2978	360	50	2900	130
		Size 40	715	3978	360	50	3900	130
		Size 50	715	4978	360	50	4900	130
		Discharge nozzle, long monodirectional arrangement, for ProtecTor door air curtains, suitable for use up to an air discharge height of 4.5 metres						
		A	B	C	D	E	F	
		Size 20	815	1978	360	50	1900	130
		Size 30	815	2978	360	50	2900	130
Size 40	815	3978	360	50	3900	130		
Size 50	815	4978	360	50	4900	130		
	Discharge nozzle, short, central	Discharge nozzle, short, central arrangement with guard for ProtecTor door air curtains, suitable for use up to an air discharge height of 3.5 metres (air discharge height reduces by 1.0 metre)						
		A	B	C	D	E	F	
		Size 20	715	1978	140	38	1900	133
		Size 30	715	2978	140	38	2900	133
		Size 40	715	3978	140	38	3900	133
		Size 50	715	4978	140	38	4900	133
		Discharge nozzle, short, central arrangement with guard for ProtecTor door air curtains, suitable for use up to an air discharge height of 4.5 metres (air discharge height reduces by 1.0 metre)						
		A	B	C	D	E	F	
		Size 20	815	1978	140	38	1900	133
		Size 30	815	2978	140	38	2900	133
Size 40	815	3978	140	38	3900	133		
Size 50	815	4978	140	38	4900	133		

Air outlet temperatures

Please refer to the performance tables (on pages 15 to 49) for the air outlet temperatures of the different air curtains. If the use of additional components results in a reduced air volume and thus a lower heat output or if a temperature difference Δt between the mean water temperature and the air inlet temperature has been selected that is not shown in the performance tables, then the air outlet temperature can be calculated as follows:

$$t_{L2} = t_{L1} + \frac{Q_{\text{eff}} \cdot 1000}{V_{L\text{eff}} \cdot C}$$

t_{L1}	[°C]	=	air inlet temperature
t_{L2}	[°C]	=	air outlet temperature
Q_{eff}	[kW]	=	eff. Heat output of the air stream
$V_{L\text{eff}}$	[m ³ /h]	=	effective air volume flow of the air curtain (taking into account accessory components)
C	[Wh/m ³ K]	=	multiplier for air outlet temperature calculation

t_{L1}	C	t_{L1}	C
[°C]	[Wh/m ³ K]	[°C]	[Wh/m ³ K]
+ 20	0.34	± 0	0.36
+ 10	0.35	- 10	0.37

Guideline values for the air outlet temperature:

- ▶ min. 35 – 40 °C (if people working in the discharge area of the unit)

Max. permissible flow temperature

The maximum permissible flow temperature of 120 °C may not be exceeded, as long periods of fan idleness lead to impermissible heating up of the motor windings and bearings.

The fan can also overheat by the use of slow-closing solenoid or motorised valve. This can interrupt the flow of medium before the fan is switched off and the heat exchanger cools down.

Water resistance

Calculate the water resistance using the water resistance diagrams (**pages 14 to 45**).

This is formed from:

- ▶ the heat output Q_{eff}
- ▶ the temperature difference of the heating medium
 $\Delta t_w = t_{w1} - t_{w2}$

- ▶ the volumetric flow rate of the heating medium

$$m = \frac{Q_{\text{eff}}}{\Delta t_w} \cdot 0.86$$

These figures apply to a mean water temperature of 70 °C but can also be used for other heating media temperatures because of the low dependence on the water temperature.

Noise

There is minimal noise from these units due to the aerodynamic design of the whisper-quiet sickle-blade fan. Flow noise is reduced because of the sickle-shaped design of the profiled blades combined with the optimised inlet nozzle.

The uniform spread over the entire frequency range, minimising blade passing noise, reduces unpleasant peaks of noise. Nevertheless, take into account the permissible noise levels when designing door air curtains.

The A-rated total sound levels, for both sound pressure and sound power, are given in the performance tables (**on pages 15 to 49**).

Sound pressure level

The A-rated sound pressure levels given in the technical data (pages 15 to 29) have been calculated with an assumed room insulation of 16 dB(A). This corresponds to a clearance of 5 m, a room volume of 3000 m³ and a reverberation time of 2.0 s (in accordance with VDI 2081). The actual sound pressure level may differ significantly from the stated figures, depending on the room geometry, absorption capacity of the space, equipment, accessories etc.

Sound power level

The sound power level describes the noise emission from the units, independently of the space and distance. The sound pressure levels can be calculated when the room geometry and absorption values are known. The sound power levels have been determined using the enveloping surface process according to DIN 45635-56.

04 ▶ Control



Stage switch / fan speed controller for 400 V AC and 230 V EC motors

Kampmann offers an extensive range of control accessories for every required function:

Model with EC motors

- ▶ manual fan speed controller, continuously variable, in conjunction with thermostat and/or door contact switch in the mains power supply
- ▶ Repair switch

Motor protection

All EC door air curtains have a built-in motor monitor, which switches off the motor in the event of motor overloading. This fault can be evaluated externally by a potential-free N/C 250 V AC / 2 A.

The entire group or individual units will be shut down in the event of a motor malfunction, depending on the control solution.

Model with AC motors

- ▶ 2-stage, 5-stage speed controllers
- ▶ Thermostats and temperature controls; optionally with timer program
- ▶ Repair switch

Motor protection

Thermal contacts (temperature monitors) are embedded in the motor windings, which open when the maximum winding temperature of 155 °C is exceeded.

Thermal contacts meet the conditions for protecting against the overload of equipment with electro-motorised drive VDE 0730. Commercial motor protection switch or bi-metal trips are not suitable as motor protection with multi-stage operated motors.

With group circuits

- ▶ Thermal contacts are connected in series. This configuration secures as many motors as needed with the motor protection device.
- ▶ Total power for the connected door air curtains should not exceed the maximum rating of the switch. Ensure that the units cannot automatically restart in the event of a fault (e.g. 2-phase, mechanical obstruction, bearing failure). All Kampmann fan speed controls are fitted with a switch-on lock in the event of a fault.
- ▶ Switch on again by turning the stage switch to zero.
- ▶ Automatic restart after power failure with switches with the option to connect to a room thermostat.

2-stage three-phase motor

Information on cable laying

Note the following points with the cable laying and wiring plans below:

- ▶ Comply with the details on the type of cable and cabling, taking into consideration VDE 0100.
- ▶ Cable type NYM-J. The requisite number of wires, including PE conductor, is stated on the cable. Cross-sections are not stated, as the cable length is involved in the calculation of the cross-section.

- ▶ If other types of cables are used, they must be at least equivalent.
- ▶ The terminals on the unit are suitable for a maximum wire cross-section of 2.5 mm².
- ▶ The electrical data listed in the following table needs to be considered when configuring the mains supply and fuses on site.

Maximum connectible door air curtains per switch

Door air curtain with 2-stage three-phase motor	Switch		
	5-stage three-phase control with room thermostat connection		2-stage, three-phase switch with room thermostat connection
	Type 30752	Type 30754	Type 30049
[Series]	[Number]	[Number]	[Number]
*20**66	2	4	5
*30**66	1	3	3
*40**66	1	2	2
*50**66	-	1	2
*20**76	1	3	3
*30**76	1	2	2
*40**76	-	1	1
*50**76	-	1	1

* Code for mounting version

** Heat exchanger version

Electrical data for ProtecTor with AC motor

ProtecTor Type	Nominal voltage [V]	Mains frequency [Hz]	Active power [kW]	Nominal current [A]	Leakage current [mA]	Max. fuse [A]	IP class	Protection class
*20**66	400	50	0.72 / 0.44	1.7 / 0.9	./.	C16	54	I
*30**66	400	50	1.08 / 0.66	2.5 / 1.4	./.	C16	54	I
*40**66	400	50	1.44 / 0.88	3.3 / 1.8	./.	C16	54	I
*50**66	400	50	1.80 / 1.10	4.2 / 2.3	./.	C16	54	I
*20**76	400	50	1.06 / 0.72	2.0 / 1.2	./.	C16	54	I
*30**76	400	50	1.59 / 1.08	3.0 / 1.9	./.	C16	54	I
*40**76	400	50	2.12 / 1.44	4.0 / 2.5	./.	C16	54	I
*50**76	400	50	2.65 / 1.80	5.0 / 3.1	./.	C16	54	I

* Code for mounting version

** Heat exchanger version

Cable laying of ProtecTor, control by 2-stage switch, type 30049

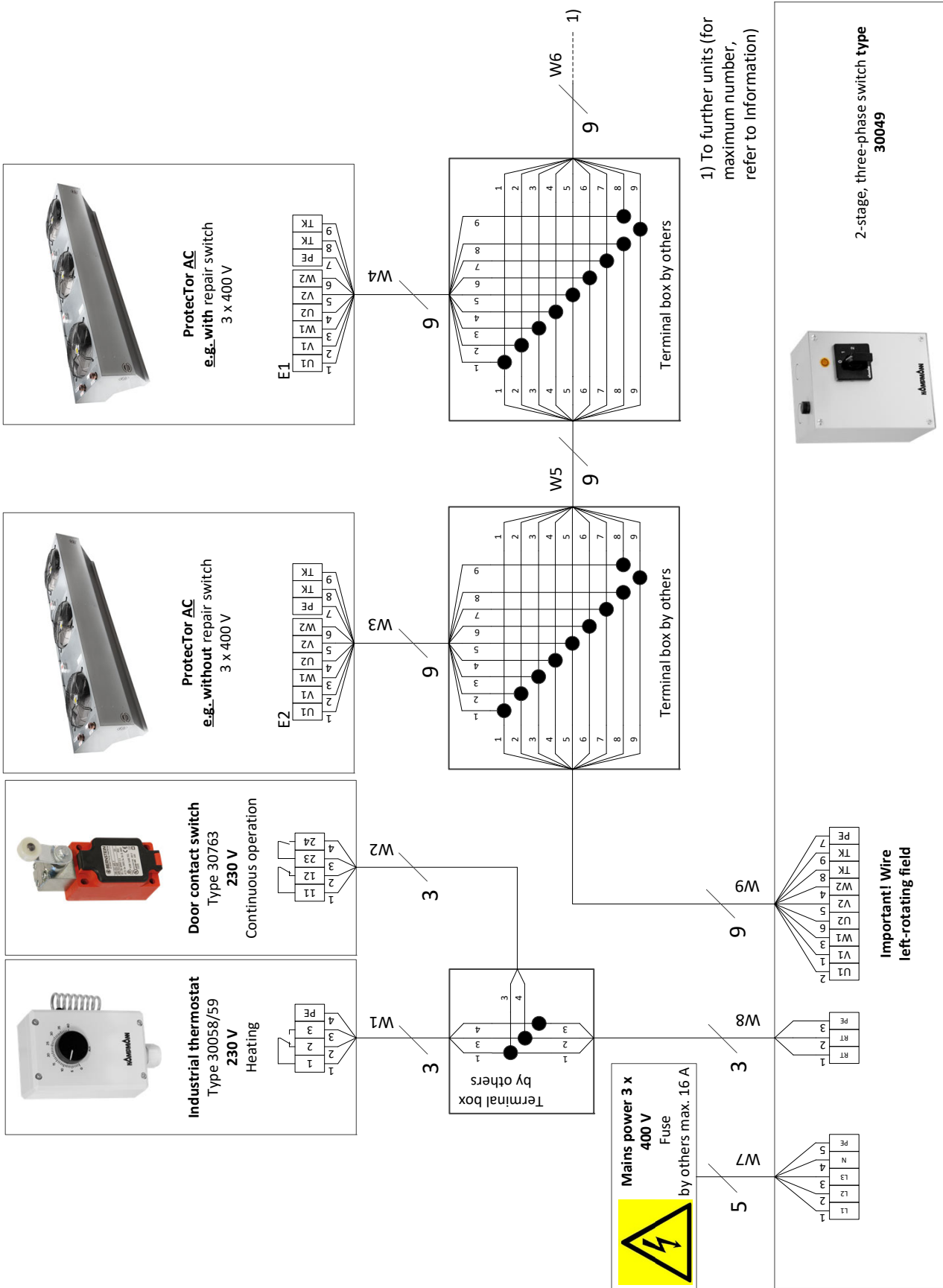

Control accessories for EC recirculating air *00

Brief description of fan speed controller, type 30510

Continuously variable fan speed controller for use in conjunction with a thermostat and/or a door contact switch. The fan speed is set manually on the fan speed controller at between 0-100%. The thermostats activate the door air curtains at the pre-set fan speed depending on the temperature.

A door contact switch or an on-site motion sensor can be used in place of the thermostat to switch on the door air curtain. A combination can also be used for activation of the door air curtains by thermostat or door contact switch. Maximum number of air curtains that can be connected
Maximum two ProtecTor door air curtains with EC motors can be controlled in parallel with fan speed controller type 30510.

230V EC motor

Information on cable laying

Note the following points

with the cable laying and wiring plans below:

- ▶ Comply with the details on the type of cable and cabling, taking into consideration VDE 0100.
- ▶ Without *: NYM-J. The requisite number of wires, including PE conductor, is stated on the cable. Cross-sections are not stated, as the cable length is involved in the calculation of the cross-section.
- ▶ With *: J-Y(ST)Y 0.8 mm, max. 100 m between the fan speed controller and the last unit; provide a shield on one side when longer than 20 m. Lay separately from high voltage lines.
- ▶ If other types of cables are used, they must be at least equivalent.

- ▶ The terminals on the unit are suitable for a maximum wire cross-section of 2.5 mm².
- ▶ All RCCBs used must be all current-sensitive (type B). When the power supply to the unit is switched on, pulsating charging currents from the capacitors in the integral EMC filter can cause residual current safety devices to trip.
- ▶ The electrical data listed in the following table needs to be considered when configuring the mains supply and fuses on site.

A maximum of 2 air curtains can be connected to fan speed controller type 30510

Electrical data for ProtecTor with EC motor

ProtecTor Type	Nominal voltage [V]	Mains frequency [Hz]	Active power [kW]	Nominal current [A]	Leakage current [mA]	Max. fuse [A]	IP class	Protection class
*20**68	400	50/60	0.92	2.0	<3.5	C16	54	I
*30**68	400	50/60	1.38	2.0	<3.5	C16	54	I
*40**68	400	50/60	1.84	4.0	<3.5	C16	54	I
*50**68	400	50/60	2.30	4.0	<3.5	C16	54	I
*20**78	400	50/60	1.70	3.8	<3.5	C16	54	I
*30**78	400	50/60	2.55	3.8	<3.5	C16	54	I
*40**78	400	50/60	3.40	7.7	<3.5	C16	54	I
*50**78	400	50/60	4.25	7.7	<3.5	C16	54	I

* Code for mounting version

** Heat exchanger version

Cable laying with ProtecTor EC (**00), control by fan speed controller type 30510

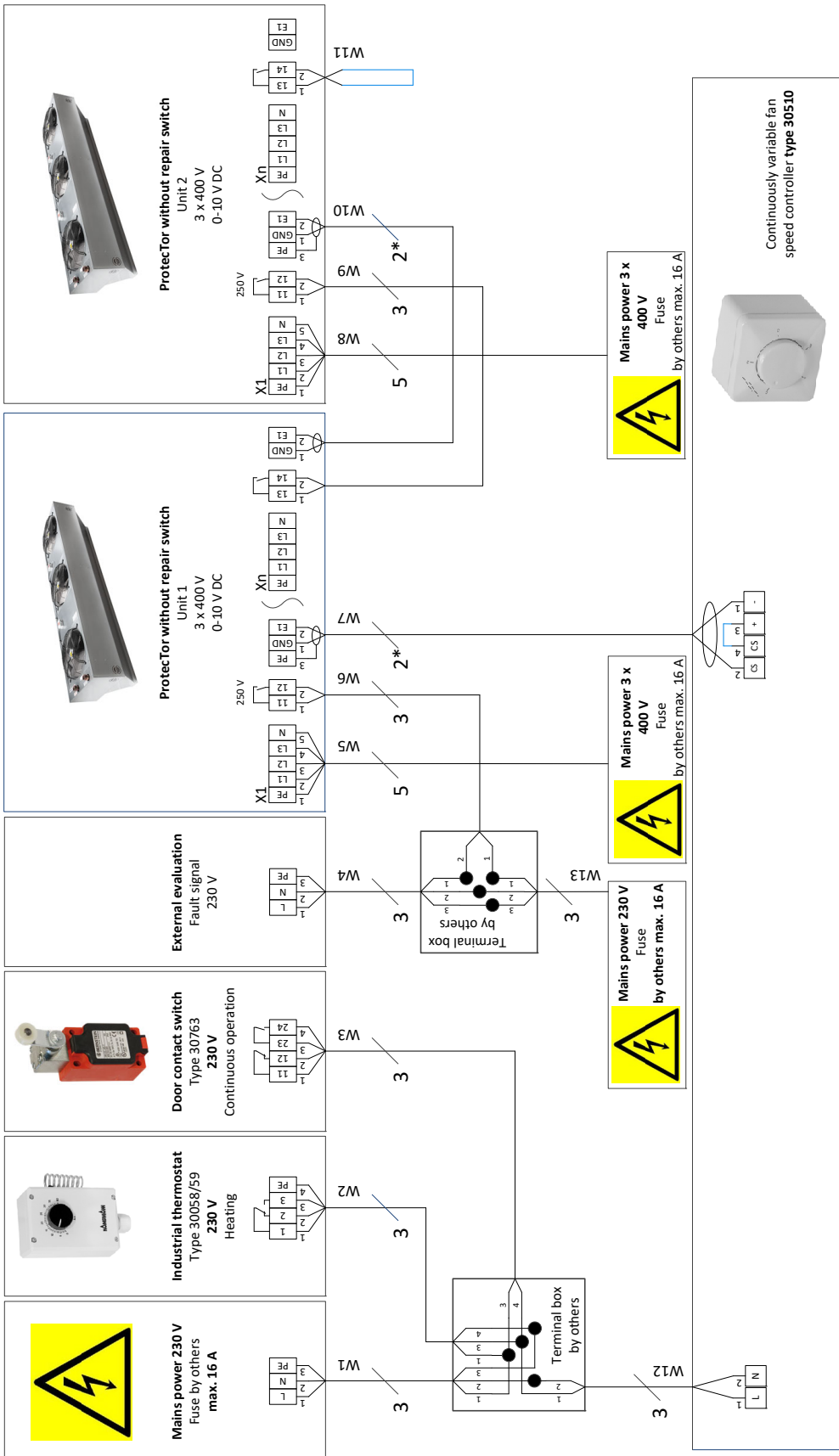

Cable laying with ProtecTor EC (*0R), control by fan speed controller type 30510

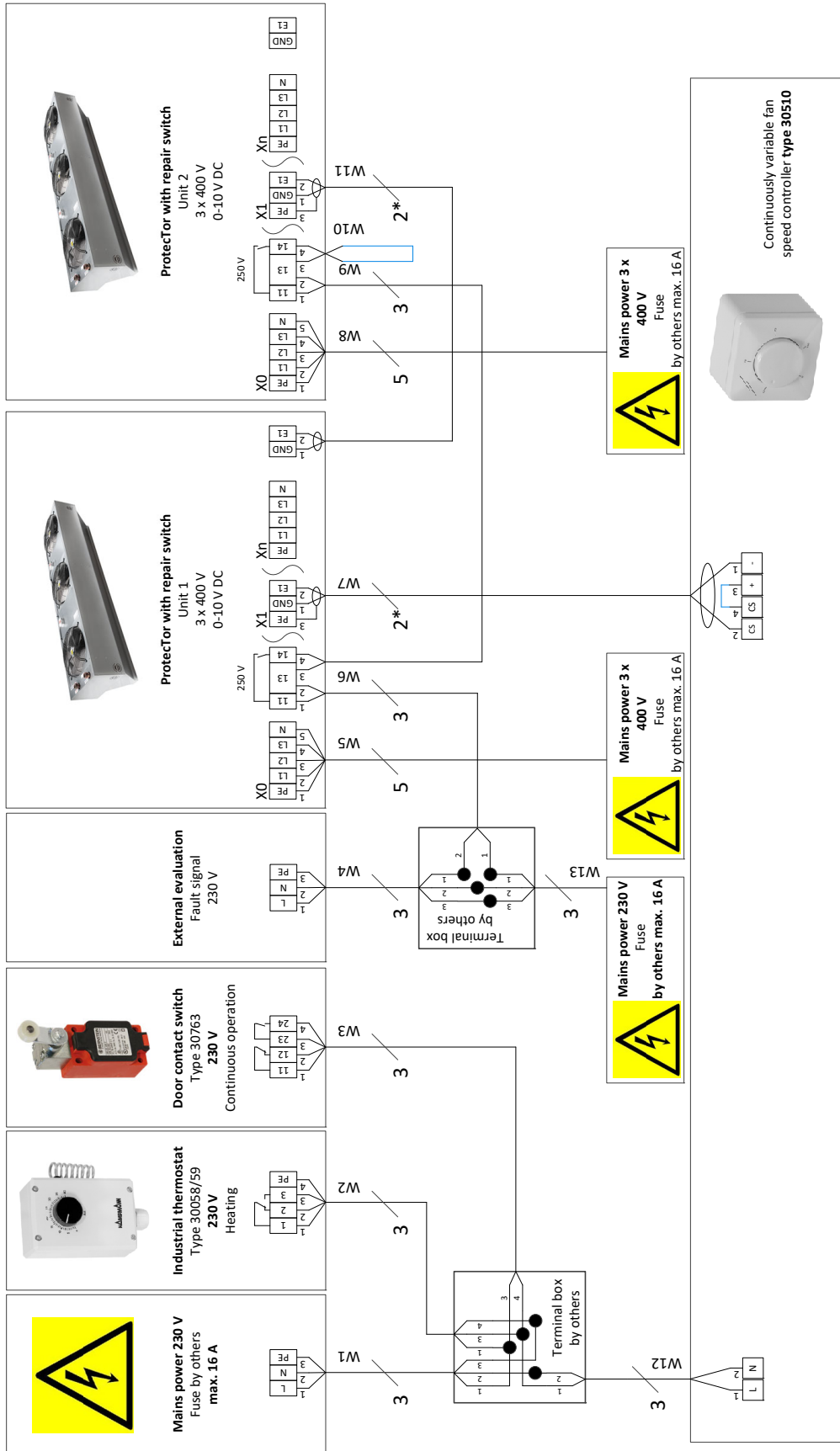

Cable laying with ProtecTor EC (*00, *0R), control by building automation system

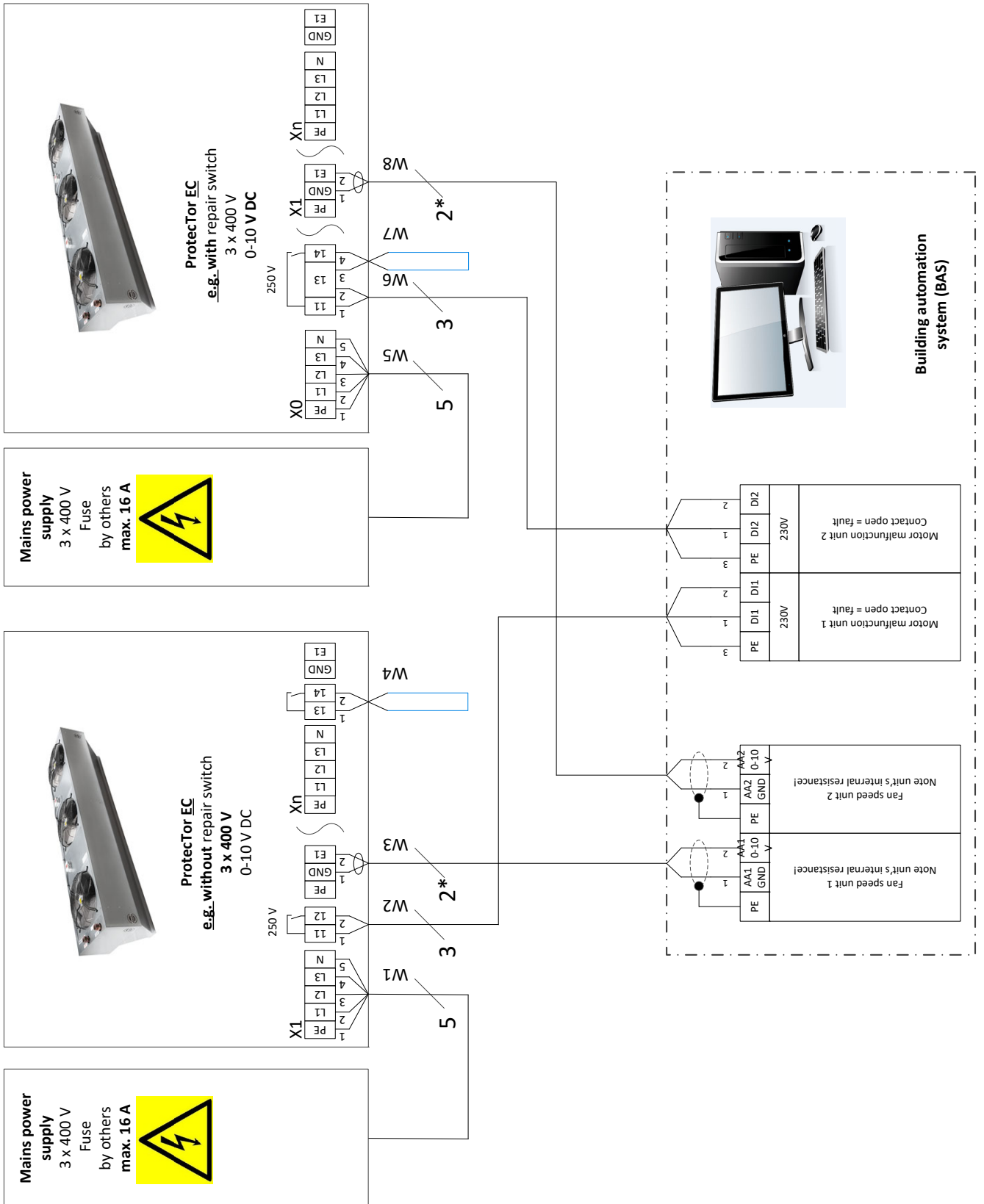

KaControl – The all-inclusive solution for 400 V AC and 230 V EC motors

ProtecTor door air curtains can be operated with KaControl electronics, supplied separately. Every ProtecTor door air curtain is thus equipped with its own “intelligence” and can be operated in a control zone via tLan or CAN bus networks.

Integration into higher-level systems

ProtecTor door air curtains with KaControl provide the option of connecting the units into the building automation system using building automation/building management system interfaces, and connecting them to Kampmann system controllers. Standard building automation standards, such as BACnet and KNX, as well as modbus, can be used for communication between KaControl and the building automation system.

Available interfaces:

- ▶ KNX
- ▶ Modbus
- ▶ CAN bus
- ▶ LON
- ▶ BACnet IP

Commissioning

Each ProtecTor door air curtain with KaControl is supplied factory-fitted with a basic program and wired ready for operation with factory presettings for all control parameters. If required, the parameters can be accessed via the operating unit (KaController) on site and changed as needed. This is also possible via the respective building automation system when using a communication card.

KaControl for ProtecTor door air curtains

The parametrisable KaControl offers a wide range of functions:

- ▶ 5-stage fan control (AC and EC)
- ▶ continuous fan control (EC only)
- ▶ activation of the unit depending on the room temperature
- ▶ control of on-site hot water shut-off valve (heating) with Open/Close valve actuator via 24 V DC output

- ▶ integrated timer program for programming day and week switching functions in the KaController unit
- ▶ operation of several door air curtains using a control unit (KaController) in a single control zone
- ▶ motor monitoring with fault signal processing
- ▶ Contact control

The door air curtain system can be switched on/off via an external contact or the fan speed can be changed by a defined value. The hot water valve can either be simultaneously opened via the contact or permanently opened or closed.

- ▶ Outside temperature-managed control

The fan speed can optionally be automatically raised via an outside temperature sensor at a certain outside temperature. The valve can also be switched on or off when the set outside temperature value is reached (summer/winter changeover).

- ▶ Management / automation level

Among others, modbus RTU provides the option here of functionally connecting units from the field level with central ventilation units. The Kampmann KaControl Visu offers the opportunity of setting up a visualisation and management system for the entire climate technology systems.

KaControl electronics, recirculating air, for AC three-phase fans

The wall-mounted control incorporates intelligent KaControl components, a module and a set of transformers. Max. load capacity 4 kW/8 A. Max. 2 ProtecTor units can be connected in parallel depending on the size.



Type 3231200

KaControl electronics, recirculating air, for EC single-phase fans

Intelligent KaControl components are incorporated in the wall-mounted control. Max. 2 ProtecTor units can be connected in parallel.



Type 3231160

KaController

The KaController offers maximum operating convenience with a large display, one-touch operation and optionally also with side function keys for quick access. Based on the principle of “as little as possible, as much as required”, even untrained users can intuitively get to grips with the control options.

The displays are language-independent using pictograms. The basic functions are inputted in a user-friendly way using the KaController.



Type 196003214002



Type 196003210001



Type 196003210002



Type 196003210006

Product features of the KaController

- ▶ plastic housing, colour similar to RAL 9010 (type 196003210001 and 196003210002) or black (type 196003210006) for surface-mounting on a flush back box or surface-mounting with a surface-mounted frame (accessory)
- ▶ high-quality design of room control units, large PCD multifunctional display with energy-saving, automatically switching LED backlight
- ▶ push-turn navigator dial with endless turn/lock function
- ▶ side function keys for quick access (only with type 196003210002)
- ▶ integral temperature sensor
 - Important!** The model in an industrial housing always needs a separate room temperature sensor
- ▶ individually adjustable basic display
- ▶ display of fault messages
- ▶ built-in weekly switching program
- ▶ password-protected parameter level

KaControl control function

The parametrisable KaControl microprocessor control offers a wealth of functions. The following default functions are factory settings for the Ultra product:

- ▶ 2-pipe applications, thermal valve actuators 24 V AC Open/Close, normally closed
- ▶ room temperature control with 2-point valve control and demand-led fan control in automatic operation or optionally fixed stage selection
- ▶ optional use of the internal or external room temperature sensor (accessory)
- ▶ in the event of an alarm being triggered on a device to which the KaController room control unit is connected, e.g. a motor malfunction is detected by the KaControl and indicated on the KaController control unit
- ▶ heating/cooling switch-over control input with 2-pipe systems
- ▶ control input can either be set to Comfort/ECO or ON/OFF switch-over
- ▶ switching output 24 V DC/max. 0.5 A parametrisable to unit alarm, heating or cooling demand (only with 2-pipe applications)
- ▶ sequential valve control (Open/Close) and fan speed

- ▶ 0-10 V DC only with control without KaController
- ▶ one slot for optional interface cards for connection to a higher-level building automation system – optionally modbus, KNX, BACnet (accessory)
- ▶ password-protected parameter level
- ▶ parallel operation of a maximum of 2 units is possible, extendible to a maximum of 30 units using an additional CANbus card type 3260301 (accessory) per unit

Any additional functions required can be parametrised and correspondingly coordinated.

Information on cable laying

- ▶ The following points need to be taken into account with the cable laying and wiring diagrams below:
- ▶ Comply with the details on the type of cable and cabling, taking into consideration VDE 0100.
- ▶ Without *: NYM-J. The requisite number of wires, including PE conductor, is stated on the cable. Cross-sections are not stated, as the cable length is involved in the calculation of the cross-section.
- ▶ With *: J-Y(ST)Y 0.8 mm. Lay separately from high voltage lines.
- ▶ With **: UNITRONIC BUS LD 0.22 mm². Lay separately from high voltage lines.
- ▶ If other types of cables are used, they must be at least equivalent.
- ▶ Length of BUS line from the KaController to control electronics 1: max. 30 m.
- ▶ Maximum number of parallel control electronics: 2 units. Maximum 30 units with a CAN bus card type 3260301 (see Accessories) required for each control electronic unit and a terminal resistor on the 1st and last control electronic unit.

- ▶ Length of BUS line from control electronics 1 to control electronics 2 max. 30 m. Max. 500 m with a CAN bus card type 3260301 (see Accessories) needed for each control electronic unit.
- ▶ Length of cable for room sensor and switching contact maximum 30 m, maximum 100 m from 1 mm²
- ▶ Length of 0-10 V control cable between the control electronics and the unit maximum 30 m; maximum 100 m from 1 mm².
- ▶ The terminals on the unit for the mains power supply are suitable for a maximum wire cross-section of 2.5 mm².
- ▶ All RCCBs used for units with EC fan must be all current-sensitive (type B). When the power supply to the unit is switched on, pulsating charging currents from the capacitors in the integral EMC filter can cause residual current safety devices to trip.
- ▶ The electrical data listed in the tables above needs to be considered when configuring the mains supply and fuses on site.

Single-circuit control system

Maximum connectible number of ProtecTor door air curtains per KaControl electronic controller, recirculating air, for AC three-phase fans

Air curtain with 2-stage three-phase motor	KaControl recirculating air control electronics Type 3231200
[Series]	[Number]
*20**66	2
*30**66	2
*40**66	2
*50**66	1
*20**76	2
*30**76	2
*40**76	1
*50**76	1

* Code for mounting version

** Heat exchanger version

Cable laying with ProtecTor EC (*00, *0R), max. 2 control electronics, each with max. 2 ProtecTor units via tLan depending on model size

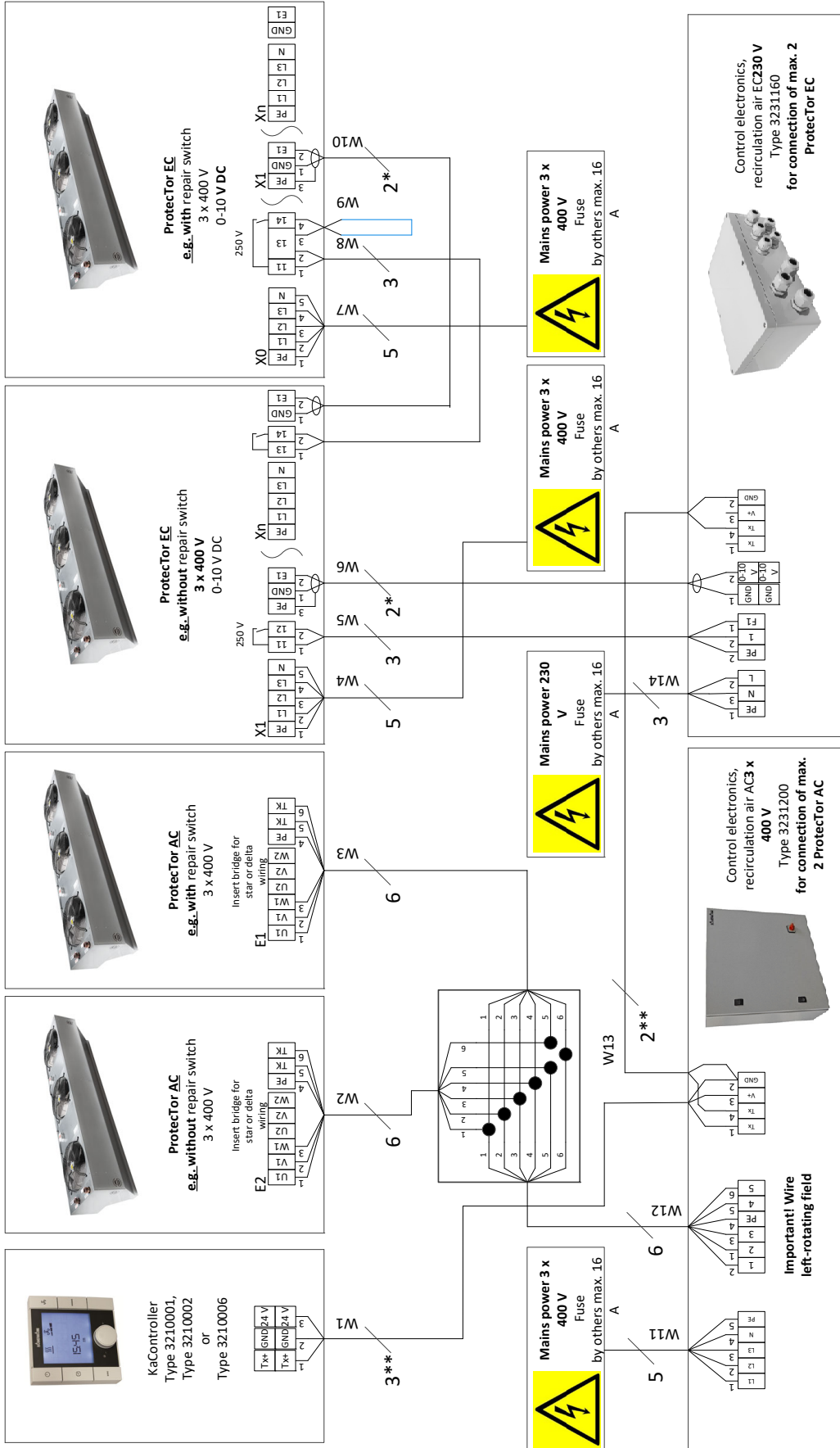

Cable laying with ProtecTor EC (*00, *0R), max. 2 control electronic units via tLan or for max. 30 control electronic units via CAN bus

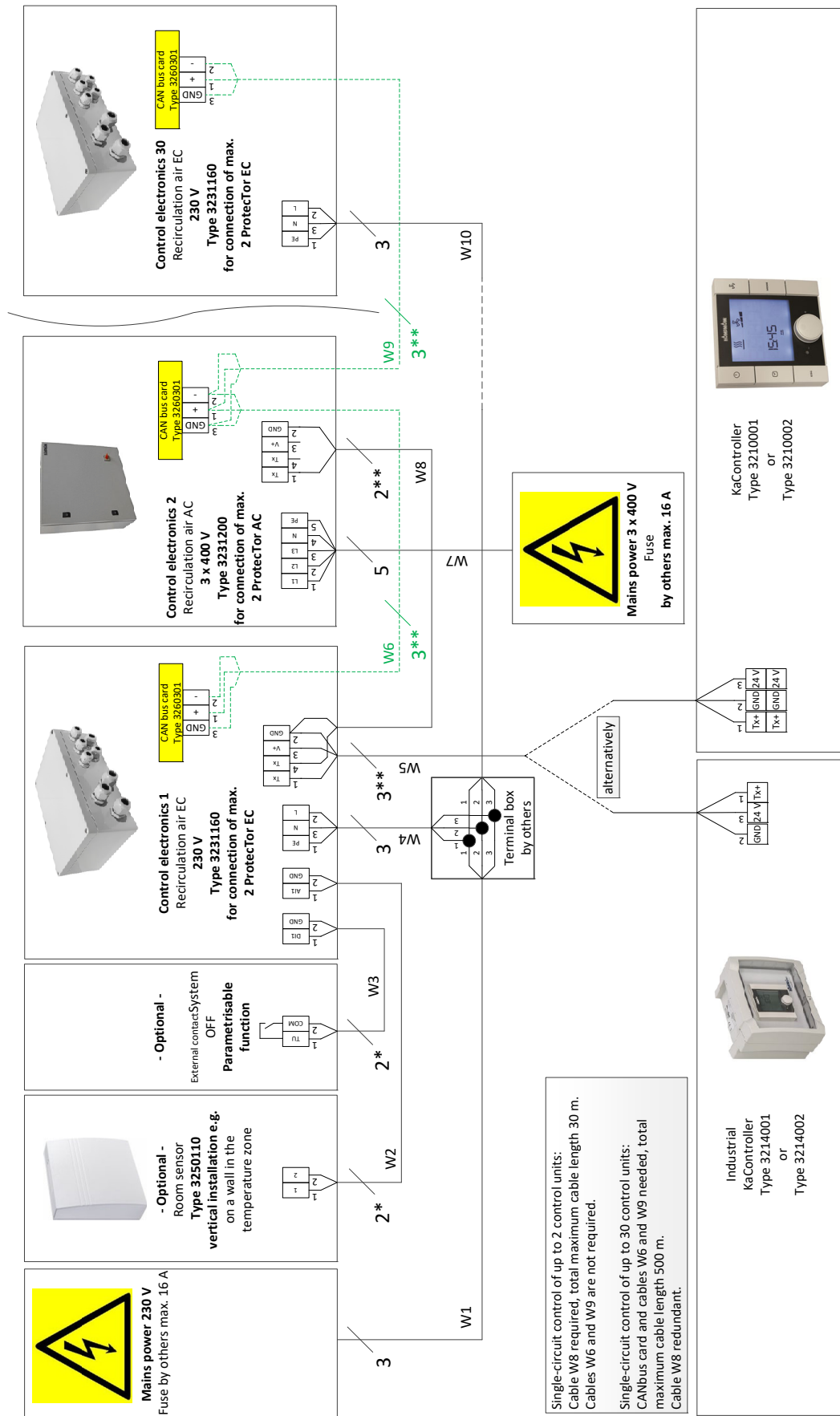

05 ▶ Ordering information

ProtecTor

Fan version	Heat exchanger model	Max. discharge height or width	Total air volume	Heat output	Installation site	Control option	Article no.
		[m]	[m³/h]	[kW]			

Model size 20, Max. door width or height 2.25 m

EC fan	copper/ aluminium	3.5	2000 – 11270	15 – 49.7	Horizontal (above the doorway), connection on left	electromechanical	255000202068
						electromechanical with frost protection thermostat	255000202068FO
						electromechanical with repair switch	255000202068OR
						frost protection thermostat and repair switch	255000202068FR
					horizontal (above the door), connection on the right	electromechanical	255001202068
						electromechanical with frost protection thermostat	255001202068FO
		Standing (to the left of the doorway)	electromechanical with repair switch	255001202068OR			
			frost protection thermostat and repair switch	255001202068FR			
		4.5	2950 – 15820	22.4 – 71.3	Standing (to the right of the doorway)	electromechanical	255003202068
						electromechanical with frost protection thermostat	255003202068FO
					Horizontal (above the doorway), connection on left	electromechanical with repair switch	255003202068OR
						frost protection thermostat and repair switch	255003202068FR
	horizontal (above the door), connection on the right				electromechanical	255002202068	
					electromechanical with frost protection thermostat	255002202068FO	
	Standing (to the right of the doorway)	electromechanical with repair switch	255002202068OR				
		frost protection thermostat and repair switch	255002202068FR				
		Horizontal (above the doorway), connection on left	electromechanical	255000202078			
			electromechanical with frost protection thermostat	255000202078FO			
		horizontal (above the door), connection on the right	electromechanical with repair switch	255000202078OR			
			frost protection thermostat and repair switch	255000202078FR			
	Standing (to the left of the doorway)	electromechanical	255001202078				
		electromechanical with frost protection thermostat	255001202078FO				
		horizontal (above the door), connection on the right	electromechanical with repair switch	255001202078OR			
			frost protection thermostat and repair switch	255001202078FR			
Standing (to the left of the doorway)		electromechanical	255003202078				
		electromechanical with frost protection thermostat	255003202078FO				
Standing (to the right of the doorway)	electromechanical with repair switch	255003202078OR					
	frost protection thermostat and repair switch	255003202078FR					
Standing (to the right of the doorway)	electromechanical	255002202078					
	electromechanical with frost protection thermostat	255002202078FO					
	Horizontal (above the doorway), connection on left	electromechanical with repair switch	255002202078OR				
		frost protection thermostat and repair switch	255002202078FR				
	horizontal (above the door), connection on the right	electromechanical	255000202078				
		electromechanical with frost protection thermostat	255000202078FO				
Standing (to the left of the doorway)	electromechanical with repair switch	255000202078OR					
	frost protection thermostat and repair switch	255000202078FR					

CONTINUED ▶

ProtecTor

Fan version	Heat exchanger model	Max. discharge height or width	Total air volume	Heat output	Installation site	Control option	Article no.
		[m]	[m³/h]	[kW]			
EC fan	steel, galvanised	3.5	2000 – 11270	15 – 49.7	Horizontal (above the doorway), connection on left	electromechanical	255000203168
						electromechanical with frost protection thermostat	255000203168FO
						electromechanical with repair switch	255000203168OR
						frost protection thermostat and repair switch	255000203168FR
					horizontal (above the door), connection on the right	electromechanical	255001203168
						electromechanical with frost protection thermostat	255001203168FO
						electromechanical with repair switch	255001203168OR
						frost protection thermostat and repair switch	255001203168FR
					Standing (to the left of the doorway)	electromechanical	255003203168
						electromechanical with frost protection thermostat	255003203168FO
						electromechanical with repair switch	255003203168OR
						frost protection thermostat and repair switch	255003203168FR
		Standing (to the right of the doorway)	electromechanical	255002203168			
			electromechanical with frost protection thermostat	255002203168FO			
			electromechanical with repair switch	255002203168OR			
			frost protection thermostat and repair switch	255002203168FR			
		4.5	2950 – 15820	22.4 – 71.3	Horizontal (above the doorway), connection on left	electromechanical	255000203178
						electromechanical with frost protection thermostat	255000203178FO
						electromechanical with repair switch	255000203178OR
						frost protection thermostat and repair switch	255000203178FR
					horizontal (above the door), connection on the right	electromechanical	255001203178
						electromechanical with frost protection thermostat	255001203178FO
						electromechanical with repair switch	255001203178OR
						frost protection thermostat and repair switch	255001203178FR
Standing (to the left of the doorway)	electromechanical				255003203178		
	electromechanical with frost protection thermostat				255003203178FO		
	electromechanical with repair switch				255003203178OR		
	frost protection thermostat and repair switch				255003203178FR		
Standing (to the right of the doorway)	electromechanical	255002203178					
	electromechanical with frost protection thermostat	255002203178FO					
	electromechanical with repair switch	255002203178OR					
	frost protection thermostat and repair switch	255002203178FR					
EC fan	without heat exchanger	3.5	2240 – 12600	---	Horizontal (above the doorway), connection on left	electromechanical	255000200068
						electromechanical with repair switch	255000200068OR
					Standing (to the left of the doorway)	electromechanical	255003200068
						electromechanical with repair switch	255003200068OR
					Standing (to the right of the doorway)	electromechanical	255002200068
						electromechanical with repair switch	255002200068OR
		4.5	3300 – 17690	---	Horizontal (above the doorway), connection on left	electromechanical	255000200078
						electromechanical with repair switch	255000200078OR
					Standing (to the left of the doorway)	electromechanical	255003200078
						electromechanical with repair switch	255003200078OR
					Standing (to the right of the doorway)	electromechanical	255002200078
						electromechanical with repair switch	255002200078OR

CONTINUED ▶

ProtecTor

Fan version	Heat exchanger model	Max. discharge height or width	Total air volume	Heat output	Installation site	Control option	Article no.
		[m]	[m³/h]	[kW]			
AC fan	copper/ aluminium	3.5	7300 – 9250	33.3 – 43.3	Standing (to the left of the doorway)	electromechanical	255003202066
						electromechanical with frost protection thermostat	255003202066F0
						electromechanical with repair switch	2550032020660R
						frost protection thermostat and repair switch	255003202066FR
					Standing (to the right of the doorway)	electromechanical	255002202066
						electromechanical with frost protection thermostat	255002202066F0
						electromechanical with repair switch	2550022020660R
						frost protection thermostat and repair switch	255002202066FR
					Horizontal (above the doorway), connection on left	electromechanical	255000202066
						electromechanical with frost protection thermostat	255000202066F0
						electromechanical with repair switch	2550002020660R
						frost protection thermostat and repair switch	255000202066FR
		4.5	11950 – 14350	53 – 66.7	Standing (to the left of the doorway)	electromechanical	255003202076
						electromechanical with frost protection thermostat	255003202076F0
						electromechanical with repair switch	2550032020760R
						frost protection thermostat and repair switch	255003202076FR
					Standing (to the right of the doorway)	electromechanical	255002202076
						electromechanical with frost protection thermostat	255002202076F0
						electromechanical with repair switch	2550022020760R
						frost protection thermostat and repair switch	255002202076FR
					Horizontal (above the doorway), connection on left	electromechanical	255000202076
						electromechanical with frost protection thermostat	255000202076F0
						electromechanical with repair switch	2550002020760R
						frost protection thermostat and repair switch	255000202076FR

CONTINUED ►

ProtecTor

Fan version	Heat exchanger model	Max. discharge height or width	Total air volume	Heat output	Installation site	Control option	Article no.
		[m]	[m³/h]	[kW]			
AC fan	steel, galvanised	3.5	7300 – 9250	33.3 – 43.3	Standing (to the left of the doorway)	electromechanical	255003203166
						electromechanical with frost protection thermostat	255003203166FO
						electromechanical with repair switch	255003203166OR
						frost protection thermostat and repair switch	255003203166FR
					Standing (to the right of the doorway)	electromechanical	255002203166
						electromechanical with frost protection thermostat	255002203166FO
						electromechanical with repair switch	255002203166OR
						frost protection thermostat and repair switch	255002203166FR
					Horizontal (above the doorway), connection on left	electromechanical	255000203166
						electromechanical with frost protection thermostat	255000203166FO
						electromechanical with repair switch	255000203166OR
						frost protection thermostat and repair switch	255000203166FR
		horizontal (above the door), connection on the right	electromechanical	255001203166			
			electromechanical with frost protection thermostat	255001203166FO			
			electromechanical with repair switch	255001203166OR			
			frost protection thermostat and repair switch	255001203166FR			
		4.5	11950 – 14350	53 – 66.7	Standing (to the left of the doorway)	electromechanical	255003203176
						electromechanical with frost protection thermostat	255003203176FO
						electromechanical with repair switch	255003203176OR
						frost protection thermostat and repair switch	255003203176FR
					Standing (to the right of the doorway)	electromechanical	255002203176
						electromechanical with frost protection thermostat	255002203176FO
						electromechanical with repair switch	255002203176OR
						frost protection thermostat and repair switch	255002203176FR
Horizontal (above the doorway), connection on left	electromechanical				255000203176		
	electromechanical with frost protection thermostat				255000203176FO		
	electromechanical with repair switch				255000203176OR		
	frost protection thermostat and repair switch				255000203176FR		
horizontal (above the door), connection on the right	electromechanical	255001203176					
	electromechanical with frost protection thermostat	255001203176FO					
	electromechanical with repair switch	255001203176OR					
	frost protection thermostat and repair switch	255001203176FR					
AC fan	without heat exchanger	3.5	8160 – 10400	---	Standing (to the left of the doorway)	electromechanical	255003200066
						electromechanical with repair switch	255003200066OR
					Standing (to the right of the doorway)	electromechanical	255002200066
						electromechanical with repair switch	255002200066OR
					Horizontal (above the doorway), connection on left	electromechanical	255000200066
						electromechanical with repair switch	255000200066OR
		4.5	13250 – 16050	---	Standing (to the left of the doorway)	electromechanical	255003200076
						electromechanical with repair switch	255003200076OR
					Standing (to the right of the doorway)	electromechanical	255002200076
						electromechanical with repair switch	255002200076OR
					Horizontal (above the doorway), connection on left	electromechanical	255000200076
						electromechanical with repair switch	255000200076OR

CONTINUED ▶

ProtecTor

Fan version	Heat exchanger model	Max. discharge height or width	Total air volume	Heat output	Installation site	Control option	Article no.
		[m]	[m³/h]	[kW]			

Model size 30, Max. door width or height 3.25 m

EC fan	copper/ aluminium	3.5	2980 – 16910	22.4 – 74.5	Horizontal (above the doorway), connection on left	electromechanical	255000302068
						electromechanical with frost protection thermostat	255000302068FO
						electromechanical with repair switch	255000302068OR
						frost protection thermostat and repair switch	255000302068FR
					horizontal (above the door), connection on the right	electromechanical	255001302068
						electromechanical with frost protection thermostat	255001302068FO
						electromechanical with repair switch	255001302068OR
						frost protection thermostat and repair switch	255001302068FR
					Standing (to the left of the doorway)	electromechanical	255003302068
						electromechanical with frost protection thermostat	255003302068FO
						electromechanical with repair switch	255003302068OR
						frost protection thermostat and repair switch	255003302068FR
	Standing (to the right of the doorway)	electromechanical	255002302068				
		electromechanical with frost protection thermostat	255002302068FO				
		electromechanical with repair switch	255002302068OR				
		frost protection thermostat and repair switch	255002302068FR				
	4.5	4430 – 23720	33.7 – 107.3	Horizontal (above the doorway), connection on left	electromechanical	255000302078	
					electromechanical with frost protection thermostat	255000302078FO	
					electromechanical with repair switch	255000302078OR	
					frost protection thermostat and repair switch	255000302078FR	
				horizontal (above the door), connection on the right	electromechanical	255001302078	
					electromechanical with frost protection thermostat	255001302078FO	
					electromechanical with repair switch	255001302078OR	
					frost protection thermostat and repair switch	255001302078FR	
Standing (to the left of the doorway)				electromechanical	255003302078		
				electromechanical with frost protection thermostat	255003302078FO		
				electromechanical with repair switch	255003302078OR		
				frost protection thermostat and repair switch	255003302078FR		
Standing (to the right of the doorway)	electromechanical	255002302078					
	electromechanical with frost protection thermostat	255002302078FO					
	electromechanical with repair switch	255002302078OR					
	frost protection thermostat and repair switch	255002302078FR					

CONTINUED ▶

ProtecTor

Fan version	Heat exchanger model	Max. discharge height or width	Total air volume	Heat output	Installation site	Control option	Article no.
		[m]	[m³/h]	[kW]			
EC fan	steel, galvanised	3.5	2980 – 16910	22.4 – 74.5	Horizontal (above the doorway), connection on left	electromechanical	255000303168
						electromechanical with frost protection thermostat	255000303168FO
						electromechanical with repair switch	255000303168OR
						frost protection thermostat and repair switch	255000303168FR
					horizontal (above the door), connection on the right	electromechanical	255001303168
						electromechanical with frost protection thermostat	255001303168FO
						electromechanical with repair switch	255001303168OR
						frost protection thermostat and repair switch	255001303168FR
					Standing (to the left of the doorway)	electromechanical	255003303168
						electromechanical with frost protection thermostat	255003303168FO
						electromechanical with repair switch	255003303168OR
						frost protection thermostat and repair switch	255003303168FR
		Standing (to the right of the doorway)	electromechanical	255002303168			
			electromechanical with frost protection thermostat	255002303168FO			
			electromechanical with repair switch	255002303168OR			
			frost protection thermostat and repair switch	255002303168FR			
		4.5	4430 – 23720	33.7 – 107.3	Horizontal (above the doorway), connection on left	electromechanical	255000303178
						electromechanical with frost protection thermostat	255000303178FO
						electromechanical with repair switch	255000303178OR
						frost protection thermostat and repair switch	255000303178FR
					horizontal (above the door), connection on the right	electromechanical	255001303178
						electromechanical with frost protection thermostat	255001303178FO
						electromechanical with repair switch	255001303178OR
						frost protection thermostat and repair switch	255001303178FR
Standing (to the left of the doorway)	electromechanical				255003303178		
	electromechanical with frost protection thermostat				255003303178FO		
	electromechanical with repair switch				255003303178OR		
	frost protection thermostat and repair switch				255003303178FR		
Standing (to the right of the doorway)	electromechanical	255002303178					
	electromechanical with frost protection thermostat	255002303178FO					
	electromechanical with repair switch	255002303178OR					
	frost protection thermostat and repair switch	255002303178FR					
EC fan	without heat exchanger	3.5	3330 – 18900	---	Horizontal (above the doorway), connection on left	electromechanical	255000300068
						electromechanical with repair switch	255000300068OR
					Standing (to the left of the doorway)	electromechanical	255003300068
						electromechanical with repair switch	255003300068OR
					Standing (to the right of the doorway)	electromechanical	255002300068
						electromechanical with repair switch	255002300068OR
		4.5	4960 – 26520	---	Horizontal (above the doorway), connection on left	electromechanical	255000300078
						electromechanical with repair switch	255000300078OR
					Standing (to the left of the doorway)	electromechanical	255003300078
						electromechanical with repair switch	255003300078OR
					Standing (to the right of the doorway)	electromechanical	255002300078
						electromechanical with repair switch	255002300078OR

CONTINUED ▶

ProtecTor

Fan version	Heat exchanger model	Max. discharge height or width	Total air volume	Heat output	Installation site	Control option	Article no.
		[m]	[m³/h]	[kW]			
AC fan	copper/ aluminium	3.5	11000 – 13900	50 – 65	Standing (to the left of the doorway)	electromechanical	255003302066
						electromechanical with frost protection thermostat	255003302066F0
						electromechanical with repair switch	2550033020660R
						frost protection thermostat and repair switch	255003302066FR
						electromechanical	255002302066
						electromechanical with frost protection thermostat	255002302066F0
					Standing (to the right of the doorway)	electromechanical with repair switch	2550023020660R
						frost protection thermostat and repair switch	255002302066FR
						electromechanical	255000302066
						electromechanical with frost protection thermostat	255000302066F0
						electromechanical with repair switch	2550003020660R
						frost protection thermostat and repair switch	255000302066FR
		Horizontal (above the doorway), connection on left	electromechanical	255003302076			
			electromechanical with frost protection thermostat	255003302076F0			
			electromechanical with repair switch	2550033020760R			
			frost protection thermostat and repair switch	255003302076FR			
			electromechanical	255002302076			
			electromechanical with frost protection thermostat	255002302076F0			
		4.5	17900 – 21500	79.5 – 100.3	Standing (to the left of the doorway)	electromechanical with repair switch	2550023020760R
						frost protection thermostat and repair switch	255002302076FR
						electromechanical	255000302076
						electromechanical with frost protection thermostat	255000302076F0
						electromechanical with repair switch	2550003020760R
						frost protection thermostat and repair switch	255000302076FR
Standing (to the right of the doorway)	electromechanical				255003302076		
	electromechanical with frost protection thermostat				255003302076F0		
	electromechanical with repair switch				2550033020760R		
	frost protection thermostat and repair switch				255003302076FR		
	electromechanical				255002302076		
	electromechanical with frost protection thermostat				255002302076F0		
Horizontal (above the doorway), connection on left	electromechanical with repair switch	2550023020760R					
	frost protection thermostat and repair switch	255002302076FR					
	electromechanical	255000302076					
	electromechanical with frost protection thermostat	255000302076F0					
	electromechanical with repair switch	2550003020760R					
	frost protection thermostat and repair switch	255000302076FR					

CONTINUED ▶

ProtecTor

Fan version	Heat exchanger model	Max. discharge height or width	Total air volume	Heat output	Installation site	Control option	Article no.
		[m]	[m³/h]	[kW]			
AC fan	steel, galvanised	3.5	11000 – 13900	50 – 65	Standing (to the left of the doorway)	electromechanical	255003303166
						electromechanical with frost protection thermostat	255003303166FO
						electromechanical with repair switch	255003303166OR
						frost protection thermostat and repair switch	255003303166FR
					Standing (to the right of the doorway)	electromechanical	255002303166
						electromechanical with frost protection thermostat	255002303166FO
						electromechanical with repair switch	255002303166OR
						frost protection thermostat and repair switch	255002303166FR
					Horizontal (above the doorway), connection on left	electromechanical	255000303166
						electromechanical with frost protection thermostat	255000303166FO
						electromechanical with repair switch	255000303166OR
						frost protection thermostat and repair switch	255000303166FR
		horizontal (above the door), connection on the right	electromechanical	255001303166			
			electromechanical with frost protection thermostat	255001303166FO			
			electromechanical with repair switch	255001303166OR			
			frost protection thermostat and repair switch	255001303166FR			
		4.5	17900 – 21500	79.5 – 100.3	Standing (to the left of the doorway)	electromechanical	255003303176
						electromechanical with frost protection thermostat	255003303176FO
						electromechanical with repair switch	255003303176OR
						frost protection thermostat and repair switch	255003303176FR
					Standing (to the right of the doorway)	electromechanical	255002303176
						electromechanical with frost protection thermostat	255002303176FO
						electromechanical with repair switch	255002303176OR
						frost protection thermostat and repair switch	255002303176FR
Horizontal (above the doorway), connection on left	electromechanical				255000303176		
	electromechanical with frost protection thermostat				255000303176FO		
	electromechanical with repair switch				255000303176OR		
	frost protection thermostat and repair switch				255000303176FR		
horizontal (above the door), connection on the right	electromechanical	255001303176					
	electromechanical with frost protection thermostat	255001303176FO					
	electromechanical with repair switch	255001303176OR					
	frost protection thermostat and repair switch	255001303176FR					
AC fan	without heat exchanger	3.5	12250 – 15600	---	Standing (to the left of the doorway)	electromechanical	255003300066
						electromechanical with repair switch	255003300066OR
					Standing (to the right of the doorway)	electromechanical	255002300066
						electromechanical with repair switch	255002300066OR
					Horizontal (above the doorway), connection on left	electromechanical	255000300066
						electromechanical with repair switch	255000300066OR
		4.5	19900 – 24100	---	Standing (to the left of the doorway)	electromechanical	255003300076
						electromechanical with repair switch	255003300076OR
					Standing (to the right of the doorway)	electromechanical	255002300076
						electromechanical with repair switch	255002300076OR
					Horizontal (above the doorway), connection on left	electromechanical	255000300076
						electromechanical with repair switch	255000300076OR

CONTINUED ▶

ProtecTor

Fan version	Heat exchanger model	Max. discharge height or width	Total air volume	Heat output	Installation site	Control option	Article no.
		[m]	[m³/h]	[kW]			

Model size 40, Max. door width or height 4.25 m

EC fan	copper/ aluminium	3.5	3970 – 22550	30 – 99.4	Horizontal (above the doorway), connection on left	electromechanical	255000402068	
						electromechanical with frost protection thermostat	255000402068F0	
						electromechanical with repair switch	255000402068FR	
					horizontal (above the door), connection on the right	frost protection thermostat and repair switch	255000402068FR	
						electromechanical	255001402068	
						electromechanical with frost protection thermostat	255001402068F0	
		4.5	5910 – 31640	45.1 – 143.5	Standing (to the left of the doorway)	electromechanical with repair switch	255001402068FR	
						frost protection thermostat and repair switch	255003402068FR	
						electromechanical	255003402068	
					Standing (to the right of the doorway)	electromechanical with frost protection thermostat	255003402068F0	
						electromechanical with repair switch	255002402068	
						frost protection thermostat and repair switch	255002402068FR	
					Horizontal (above the doorway), connection on left	electromechanical	255000402078	
						electromechanical with frost protection thermostat	255000402078F0	
						electromechanical with repair switch	255000402078FR	
					horizontal (above the door), connection on the right	frost protection thermostat and repair switch	255000402078FR	
						electromechanical	255001402078	
						electromechanical with frost protection thermostat	255001402078F0	
						Standing (to the left of the doorway)	electromechanical with repair switch	255001402078FR
							frost protection thermostat and repair switch	255001402078FR
							electromechanical	255003402078
						Standing (to the right of the doorway)	electromechanical with frost protection thermostat	255003402078F0
							electromechanical with repair switch	255003402078FR
							frost protection thermostat and repair switch	255002402078
<p>▶ CONTINUED ▶</p>								

ProtecTor

Fan version	Heat exchanger model	Max. discharge height or width	Total air volume	Heat output	Installation site	Control option	Article no.
		[m]	[m³/h]	[kW]			
EC fan	steel, galvanised	3.5	3970 – 22550	30 – 99.4	Horizontal (above the doorway), connection on left	electromechanical	255000403168
						electromechanical with frost protection thermostat	255000403168FO
						electromechanical with repair switch	255000403168OR
						frost protection thermostat and repair switch	255000403168FR
					horizontal (above the door), connection on the right	electromechanical	255001403168
						electromechanical with frost protection thermostat	255001403168FO
						electromechanical with repair switch	255001403168OR
						frost protection thermostat and repair switch	255001403168FR
					Standing (to the left of the doorway)	electromechanical	255003403168
						electromechanical with frost protection thermostat	255003403168FO
						electromechanical with repair switch	255003403168OR
						frost protection thermostat and repair switch	255003403168FR
		Standing (to the right of the doorway)	electromechanical	255002403168			
			electromechanical with frost protection thermostat	255002403168FO			
			electromechanical with repair switch	255002403168OR			
			frost protection thermostat and repair switch	255002403168FR			
		4.5	5910 – 31640	45.1 – 143.5	Horizontal (above the doorway), connection on left	electromechanical	255000403178
						electromechanical with frost protection thermostat	255000403178FO
						electromechanical with repair switch	255000403178OR
						frost protection thermostat and repair switch	255000403178FR
					horizontal (above the door), connection on the right	electromechanical	255001403178
						electromechanical with frost protection thermostat	255001403178FO
						electromechanical with repair switch	255001403178OR
						frost protection thermostat and repair switch	255001403178FR
Standing (to the left of the doorway)	electromechanical				255003403178		
	electromechanical with frost protection thermostat				255003403178FO		
	electromechanical with repair switch				255003403178OR		
	frost protection thermostat and repair switch				255003403178FR		
Standing (to the right of the doorway)	electromechanical	255002403178					
	electromechanical with frost protection thermostat	255002403178FO					
	electromechanical with repair switch	255002403178OR					
	frost protection thermostat and repair switch	255002403178FR					
EC fan	without heat exchanger	3.5	4440 – 25200	---	Horizontal (above the doorway), connection on left	electromechanical	255000400068
						electromechanical with repair switch	255000400068OR
					Standing (to the left of the doorway)	electromechanical	255003400068
						electromechanical with repair switch	255003400068OR
					Standing (to the right of the doorway)	electromechanical	255002400068
						electromechanical with repair switch	255002400068OR
		4.5	940 – 35370	---	Horizontal (above the doorway), connection on left	electromechanical	255000400078
						electromechanical with repair switch	255000400078OR
					Standing (to the left of the doorway)	electromechanical	255003400078
						electromechanical with repair switch	255003400078OR
					Standing (to the right of the doorway)	electromechanical	255002400078
						electromechanical with repair switch	255002400078OR

CONTINUED ▶

ProtecTor

Fan version	Heat exchanger model	Max. discharge height or width	Total air volume	Heat output	Installation site	Control option	Article no.
		[m]	[m³/h]	[kW]			
AC fan	copper/ aluminium	3.5	14700 – 18500	66.6 – 86.7	Standing (to the left of the doorway)	electromechanical	255003402066
						electromechanical with frost protection thermostat	255003402066F0
						electromechanical with repair switch	2550034020660R
						frost protection thermostat and repair switch	255003402066FR
					Standing (to the right of the doorway)	electromechanical	255002402066
						electromechanical with frost protection thermostat	255002402066F0
						electromechanical with repair switch	2550024020660R
						frost protection thermostat and repair switch	255002402066FR
					Horizontal (above the doorway), connection on left	electromechanical	255000402066
						electromechanical with frost protection thermostat	255000402066F0
						electromechanical with repair switch	2550004020660R
						frost protection thermostat and repair switch	255000402066FR
		4.5	23900 – 28600	106 – 133.8	Standing (to the left of the doorway)	electromechanical	255003402076
						electromechanical with frost protection thermostat	255003402076F0
						electromechanical with repair switch	2550034020760R
						frost protection thermostat and repair switch	255003402076FR
					Standing (to the right of the doorway)	electromechanical	255002402076
						electromechanical with frost protection thermostat	255002402076F0
						electromechanical with repair switch	2550024020760R
						frost protection thermostat and repair switch	255002402076FR
					Horizontal (above the doorway), connection on left	electromechanical	255000402076
						electromechanical with frost protection thermostat	255000402076F0
						electromechanical with repair switch	2550004020760R
						frost protection thermostat and repair switch	255000402076FR

CONTINUED ►

ProtecTor

Fan version	Heat exchanger model	Max. discharge height or width	Total air volume	Heat output	Installation site	Control option	Article no.
		[m]	[m³/h]	[kW]			
AC fan	steel, galvanised	3.5	14700 – 18500	66.6 – 86.7	Standing (to the left of the doorway)	electromechanical	255003403166
						electromechanical with frost protection thermostat	255003403166FO
						electromechanical with repair switch	255003403166OR
						frost protection thermostat and repair switch	255003403166FR
					Standing (to the right of the doorway)	electromechanical	255002403166
						electromechanical with frost protection thermostat	255002403166FO
						electromechanical with repair switch	255002403166OR
						frost protection thermostat and repair switch	255002403166FR
					Horizontal (above the doorway), connection on left	electromechanical	255000403166
						electromechanical with frost protection thermostat	255000403166FO
						electromechanical with repair switch	255000403166OR
						frost protection thermostat and repair switch	255000403166FR
		horizontal (above the door), connection on the right	electromechanical	255001403166			
			electromechanical with frost protection thermostat	255001403166FO			
			electromechanical with repair switch	255001403166OR			
			frost protection thermostat and repair switch	255001403166FR			
		4.5	23900 – 28600	106 – 133.8	Standing (to the left of the doorway)	electromechanical	255003403176
						electromechanical with frost protection thermostat	255003403176FO
						electromechanical with repair switch	255003403176OR
						frost protection thermostat and repair switch	255003403176FR
					Standing (to the right of the doorway)	electromechanical	255002403176
						electromechanical with frost protection thermostat	255002403176FO
						electromechanical with repair switch	255002403176OR
						frost protection thermostat and repair switch	255002403176FR
Horizontal (above the doorway), connection on left	electromechanical				255000403176		
	electromechanical with frost protection thermostat				255000403176FO		
	electromechanical with repair switch				255000403176OR		
	frost protection thermostat and repair switch				255000403176FR		
horizontal (above the door), connection on the right	electromechanical	255001403176					
	electromechanical with frost protection thermostat	255001403176FO					
	electromechanical with repair switch	255001403176OR					
	frost protection thermostat and repair switch	255001403176FR					
AC fan	without heat exchanger	3.5	16300 – 20800	---	Standing (to the left of the doorway)	electromechanical	255003400066
						electromechanical with repair switch	255003400066OR
					Standing (to the right of the doorway)	electromechanical	255002400066
						electromechanical with repair switch	255002400066OR
					Horizontal (above the doorway), connection on left	electromechanical	255000400066
						electromechanical with repair switch	255000400066OR
		4.5	26600 – 32100	---	Standing (to the left of the doorway)	electromechanical	255003400076
						electromechanical with repair switch	255003400076OR
					Standing (to the right of the doorway)	electromechanical	255002400076
						electromechanical with repair switch	255002400076OR
					Horizontal (above the doorway), connection on left	electromechanical	255000400076
						electromechanical with repair switch	255000400076OR

CONTINUED ▶

ProtecTor

Fan version	Heat exchanger model	Max. discharge height or width	Total air volume	Heat output	Installation site	Control option	Article no.
		[m]	[m³/h]	[kW]			

Model size 50, Max. door width or height 5.25 m

EC fan	copper/ aluminium	3.5	4960 – 28190	37.3 – 123.9	Horizontal (above the doorway), connection on left	electromechanical	255000502068
						electromechanical with frost protection thermostat	255000502068FO
						electromechanical with repair switch	255000502068OR
						frost protection thermostat and repair switch	255000502068FR
						electromechanical	255001502068
						electromechanical with frost protection thermostat	255001502068FO
		electromechanical with repair switch	255001502068OR				
		frost protection thermostat and repair switch	255001502068FR				
		horizontal (above the door), connection on the right	electromechanical	255003502068			
			electromechanical with frost protection thermostat	255003502068FO			
			electromechanical with repair switch	255003502068OR			
			frost protection thermostat and repair switch	255003502068FR			
	electromechanical		255002502068				
	electromechanical with frost protection thermostat		255002502068FO				
	Standing (to the left of the doorway)	electromechanical with repair switch	255002502068OR				
		frost protection thermostat and repair switch	255002502068FR				
		Standing (to the right of the doorway)	electromechanical	255000502078			
			electromechanical with frost protection thermostat	255000502078FO			
			electromechanical with repair switch	255000502078OR			
			frost protection thermostat and repair switch	255000502078FR			
	electromechanical		255001502078				
	electromechanical with frost protection thermostat		255001502078FO				
	horizontal (above the door), connection on the right	electromechanical with repair switch	255001502078OR				
		frost protection thermostat and repair switch	255001502078FR				
Standing (to the left of the doorway)		electromechanical	255003502078				
		electromechanical with frost protection thermostat	255003502078FO				
		electromechanical with repair switch	255003502078OR				
		frost protection thermostat and repair switch	255003502078FR				
	electromechanical	255002502078					
	electromechanical with frost protection thermostat	255002502078FO					
Standing (to the right of the doorway)	electromechanical with repair switch	255002502078OR					
	frost protection thermostat and repair switch	255002502078FR					

CONTINUED ▶

ProtecTor

Fan version	Heat exchanger model	Max. discharge height or width	Total air volume	Heat output	Installation site	Control option	Article no.
		[m]	[m³/h]	[kW]			
EC fan	steel, galvanised	3.5	4960 – 28190	37.3 – 123.9	Horizontal (above the doorway), connection on left	electromechanical	255000503168
						electromechanical with frost protection thermostat	255000503168FO
						electromechanical with repair switch	255000503168OR
						frost protection thermostat and repair switch	255000503168FR
					horizontal (above the door), connection on the right	electromechanical	255001503168
						electromechanical with frost protection thermostat	255001503168FO
						electromechanical with repair switch	255001503168OR
						frost protection thermostat and repair switch	255001503168FR
					Standing (to the left of the doorway)	electromechanical	255003503168
						electromechanical with frost protection thermostat	255003503168FO
						electromechanical with repair switch	255003503168OR
						frost protection thermostat and repair switch	255003503168FR
		Standing (to the right of the doorway)	electromechanical	255002503168			
			electromechanical with frost protection thermostat	255002503168FO			
			electromechanical with repair switch	255002503168OR			
			frost protection thermostat and repair switch	255002503168FR			
		4.5	7380 – 39530	56.2 – 179	Horizontal (above the doorway), connection on left	electromechanical	255000503178
						electromechanical with frost protection thermostat	255000503178FO
						electromechanical with repair switch	255000503178OR
						frost protection thermostat and repair switch	255000503178FR
					horizontal (above the door), connection on the right	electromechanical	255001503178
						electromechanical with frost protection thermostat	255001503178FO
						electromechanical with repair switch	255001503178OR
						frost protection thermostat and repair switch	255001503178FR
Standing (to the left of the doorway)	electromechanical				255003503178		
	electromechanical with frost protection thermostat				255003503178FO		
	electromechanical with repair switch				255003503178OR		
	frost protection thermostat and repair switch				255003503178FR		
Standing (to the right of the doorway)	electromechanical	255002503178					
	electromechanical with frost protection thermostat	255002503178FO					
	electromechanical with repair switch	255002503178OR					
	frost protection thermostat and repair switch	255002503178FR					
EC fan	without heat exchanger	3.5	5540 – 31520	---	Horizontal (above the doorway), connection on left	electromechanical	255000500068
						electromechanical with repair switch	255000500068OR
					Standing (to the left of the doorway)	electromechanical	255003500068
						electromechanical with repair switch	255003500068OR
					Standing (to the right of the doorway)	electromechanical	255002500068
						electromechanical with repair switch	255002500068OR
		4.5	8250 – 44190	---	Horizontal (above the doorway), connection on left	electromechanical	255000500078
						electromechanical with repair switch	255000500078OR
					Standing (to the left of the doorway)	electromechanical	255003500078
						electromechanical with repair switch	255003500078OR
					Standing (to the right of the doorway)	electromechanical	255002500078
						electromechanical with repair switch	255002500078OR

CONTINUED ▶

ProtecTor

Fan version	Heat exchanger model	Max. discharge height or width	Total air volume	Heat output	Installation site	Control option	Article no.
		[m]	[m³/h]	[kW]			
AC fan	copper/ aluminium	3.5	18300 – 23200	83.3 – 108.3	Horizontal (above the doorway), connection on left	electromechanical	255000502066
						electromechanical with frost protection thermostat	255000502066F0
						electromechanical with repair switch	2550005020660R
					Standing (to the left of the doorway)	frost protection thermostat and repair switch	255000502066FR
						electromechanical	255003502066
						electromechanical with frost protection thermostat	255003502066F0
						electromechanical with repair switch	2550035020660R
						frost protection thermostat and repair switch	255003502066FR
						electromechanical	255002502066
					Standing (to the right of the doorway)	electromechanical with frost protection thermostat	255002502066F0
						electromechanical with repair switch	2550025020660R
						frost protection thermostat and repair switch	255002502066FR
		4.5	29800 – 35800	132.5 – 167.2	Standing (to the left of the doorway)	electromechanical	255003502076
						electromechanical with frost protection thermostat	255003502076F0
						electromechanical with repair switch	2550035020760R
					Standing (to the right of the doorway)	frost protection thermostat and repair switch	255003502076FR
						electromechanical	255002502076
						electromechanical with frost protection thermostat	255002502076F0
						electromechanical with repair switch	2550025020760R
						frost protection thermostat and repair switch	255002502076FR
						electromechanical	255000502076
					Horizontal (above the doorway), connection on left	electromechanical with frost protection thermostat	255000502076F0
						electromechanical with repair switch	2550005020760R
						frost protection thermostat and repair switch	255000502076FR

CONTINUED ▶

ProtecTor

Fan version	Heat exchanger model	Max. discharge height or width	Total air volume	Heat output	Installation site	Control option	Article no.
		[m]	[m³/h]	[kW]			
AC fan	steel, galvanised	3.5	18300 – 23200	83.3 – 108.3	horizontal (above the door), connection on the right	electromechanical	255001503166
						electromechanical with frost protection thermostat	255001503166FO
						electromechanical with repair switch	255001503166OR
						frost protection thermostat and repair switch	255001503166FR
					Horizontal (above the doorway), connection on left	electromechanical	255000503166
						electromechanical with frost protection thermostat	255000503166FO
						electromechanical with repair switch	255000503166OR
						frost protection thermostat and repair switch	255000503166FR
					Standing (to the left of the doorway)	electromechanical	255003503166
						electromechanical with frost protection thermostat	255003503166FO
						electromechanical with repair switch	255003503166OR
						frost protection thermostat and repair switch	255003503166FR
		Standing (to the right of the doorway)	electromechanical	255002503166			
			electromechanical with frost protection thermostat	255002503166FO			
			electromechanical with repair switch	255002503166OR			
			frost protection thermostat and repair switch	255002503166FR			
		4.5	29800 – 35800	132.5 – 167.2	Standing (to the left of the doorway)	electromechanical	255003503176
						electromechanical with frost protection thermostat	255003503176FO
						electromechanical with repair switch	255003503176OR
						frost protection thermostat and repair switch	255003503176FR
					Standing (to the right of the doorway)	electromechanical	255002503176
						electromechanical with frost protection thermostat	255002503176FO
						electromechanical with repair switch	255002503176OR
						frost protection thermostat and repair switch	255002503176FR
Horizontal (above the doorway), connection on left	electromechanical				255000503176		
	electromechanical with frost protection thermostat				255000503176FO		
	electromechanical with repair switch				255000503176OR		
	frost protection thermostat and repair switch				255000503176FR		
horizontal (above the door), connection on the right	electromechanical	255001503176					
	electromechanical with frost protection thermostat	255001503176FO					
	electromechanical with repair switch	255001503176OR					
	frost protection thermostat and repair switch	255001503176FR					
AC fan	without heat exchanger	3.5	20400 – 26100	---	Horizontal (above the doorway), connection on left	electromechanical	255000500066
						electromechanical with repair switch	255000500066OR
					Standing (to the left of the doorway)	electromechanical	255003500066
						electromechanical with repair switch	255003500066OR
					Standing (to the right of the doorway)	electromechanical	255002500066
						electromechanical with repair switch	255002500066OR
		4.5	33090 – 40050	---	Standing (to the left of the doorway)	electromechanical	255003500076
						electromechanical with repair switch	255003500076OR
					Standing (to the right of the doorway)	electromechanical	255002500076
						electromechanical with repair switch	255002500076OR
					Horizontal (above the doorway), connection on left	electromechanical	255000500076
						electromechanical with repair switch	255000500076OR

ProtecTor

Fan version	Heat exchanger model	Max. discharge height or width	Total air volume	Heat output	Installation site	Control option	Article no.
		[m]	[m³/h]	[kW]			

Model size 20, Max. door width or height 2.25 m

EC fan	steel, galvanised cross-counterflow	3.5	2160 – 9580	10 – 27.9	Horizontal (above the doorway), connection on left	electromechanical	255000203368
						electromechanical with frost protection thermostat	255000203368F0
						electromechanical with repair switch	255000203368OR
					horizontal (above the door), connection on the right	frost protection thermostat and repair switch	255000203368FR
						electromechanical	255001203368
						electromechanical with frost protection thermostat	255001203368F0
		4.5	3140 – 14540	17.1 – 49.1	Horizontal (above the doorway), connection on left	electromechanical with repair switch	255001203368OR
						frost protection thermostat and repair switch	255001203368FR
						electromechanical	255000203378
					horizontal (above the door), connection on the right	electromechanical with frost protection thermostat	255000203378F0
						electromechanical with repair switch	255000203378OR
						frost protection thermostat and repair switch	255000203378FR
AC fan	steel, galvanised cross-counterflow	3.5	7300 – 9250	24.1 – 27	Horizontal (above the doorway), connection on left	electromechanical	255000203366
						electromechanical with frost protection thermostat	255000203366F0
						electromechanical with repair switch	255000203366OR
					Horizontal (above the doorway), connection on left	frost protection thermostat and repair switch	255000203366FR
						electromechanical	255000203376
						electromechanical with frost protection thermostat	255000203376F0
		4.5	11950 – 14350	42.2 – 48.6	Horizontal (above the doorway), connection on left	electromechanical with repair switch	255000203376OR
						frost protection thermostat and repair switch	255000203376FR
						electromechanical	255000203376FR

Model size 30, Max. door width or height 3.25 m

EC fan	steel, galvanised cross-counterflow	3.5	3230 – 14360	15 – 42	Horizontal (above the doorway), connection on left	electromechanical	255000303368		
						electromechanical with frost protection thermostat	255000303368F0		
						electromechanical with repair switch	255000303368OR		
					horizontal (above the door), connection on the right	frost protection thermostat and repair switch	255000303368FR		
						electromechanical	255001303368		
						electromechanical with frost protection thermostat	255001303368F0		
		4.5	4700 – 21810	25.4 – 73.1	Horizontal (above the doorway), connection on left	electromechanical with repair switch	255001303368OR		
						frost protection thermostat and repair switch	255001303368FR		
						electromechanical	255000303378		
					horizontal (above the door), connection on the right	electromechanical with frost protection thermostat	255000303378F0		
						electromechanical with repair switch	255000303378OR		
						frost protection thermostat and repair switch	255000303378FR		
		AC fan	steel, galvanised cross-counterflow	3.5	11000 – 13900	36.7 – 41.1	Horizontal (above the doorway), connection on left	electromechanical	255000303366
								electromechanical with frost protection thermostat	255000303366F0
								electromechanical with repair switch	255000303366OR
							Horizontal (above the doorway), connection on left	frost protection thermostat and repair switch	255000303366FR
								electromechanical	255000303376
								electromechanical with frost protection thermostat	255000303376F0
4.5	17900 – 21500			65.8 – 72.4	Horizontal (above the doorway), connection on left	electromechanical with repair switch	255000303376OR		
						frost protection thermostat and repair switch	255000303376FR		
						electromechanical	255000303376FR		

CONTINUED ►

ProtecTor

Fan version	Heat exchanger model	Max. discharge height or width	Total air volume	Heat output	Installation site	Control option	Article no.
		[m]	[m³/h]	[kW]			







Model size 40, Max. door width or height 4.25 m

EC fan	steel, galvanised cross-counterflow	3.5	4290 – 19150	19.9 – 56	Horizontal (above the doorway), connection on left	electromechanical	255000403368
						electromechanical with frost protection thermostat	255000403368F0
						electromechanical with repair switch	255000403368OR
					horizontal (above the door), connection on the right	frost protection thermostat and repair switch	255000403368FR
						electromechanical	2550014033368
						electromechanical with frost protection thermostat	2550014033368F0
		4.5	6280 – 29080	34 – 97.9	Horizontal (above the doorway), connection on left	electromechanical with repair switch	255001403368OR
						frost protection thermostat and repair switch	255001403368FR
						electromechanical	255000403378
					horizontal (above the door), connection on the right	electromechanical with frost protection thermostat	255000403378F0
						electromechanical with repair switch	255001403378OR
						frost protection thermostat and repair switch	255001403378FR
AC fan	steel, galvanised cross-counterflow	3.5	14700 – 18500	48.8 – 54.7	Horizontal (above the doorway), connection on left	electromechanical	255000403366
						electromechanical with frost protection thermostat	255000403366F0
						electromechanical with repair switch	255000403366OR
					horizontal (above the door), connection on the right	frost protection thermostat and repair switch	255000403366FR
						electromechanical	255000403376
						electromechanical with frost protection thermostat	255000403376F0
		4.5	23900 – 28600	87.4 – 96.8	Horizontal (above the doorway), connection on left	electromechanical with repair switch	255000403376OR
						frost protection thermostat and repair switch	255000403376FR
						electromechanical	255000403376F0

Model size 50, Max. door width or height 5.25 m







EC fan	steel, galvanised cross-counterflow	3.5	5370 – 23940	24.8 – 69.4	Horizontal (above the doorway), connection on left	electromechanical	255000503368
						electromechanical with frost protection thermostat	255000503368F0
						electromechanical with repair switch	255000503368OR
					horizontal (above the door), connection on the right	frost protection thermostat and repair switch	255000503368FR
						electromechanical	255001503368
						electromechanical with frost protection thermostat	255001503368F0
		4.5	7840 – 36360	42.3 – 121.9	Horizontal (above the doorway), connection on left	electromechanical with repair switch	255001503368OR
						frost protection thermostat and repair switch	255001503368FR
						electromechanical	255000503378
					horizontal (above the door), connection on the right	electromechanical with frost protection thermostat	255000503378F0
						electromechanical with repair switch	255000503378OR
						frost protection thermostat and repair switch	255000503378FR
AC fan	steel, galvanised cross-counterflow	3.5	18300 – 23200	61 – 68	Horizontal (above the doorway), connection on left	electromechanical	255000503366
						electromechanical with frost protection thermostat	255000503366F0
						electromechanical with repair switch	255000503366OR
					horizontal (above the door), connection on the right	frost protection thermostat and repair switch	255000503366FR
						electromechanical	255000503376
						electromechanical with frost protection thermostat	255000503376F0
		4.5	29800 – 35800	109.8 – 120.6	Horizontal (above the doorway), connection on left	electromechanical with repair switch	255000503376OR
						frost protection thermostat and repair switch	255000503376FR
						electromechanical	255000503376F0

Accessories

Article	Article	Properties	Dimensions [mm]	Suitable for	Article no.
Control accessories KaControl					
	KaController	with side operating keys, 24 V wall-mounted room control unit, with integral room temperature sensor, Colour similar to RAL 9010 pure white	86 x 52 x 86	all units with control option KaControl -C1, ProtecTor Door Air Curtains	196003210002
	Industry KaController	with side operating keys, industrial housing with hinged transparent cover, lockable, Surface-mounted, Protection class IP 65	200 x 110 x 195	all units with control option KaControl -C1, ProtecTor Door Air Curtains	196003214002
	Outside temperature sensor/industrial temperature sensor	Surface-mounted, Protection class IP 65, Colour similar to RAL 9010 pure white	63 x 68 x 57	all units with control option KaControl -C1, ProtecTor Door Air Curtains	196003250112
	KaControl control electronics	Recirculating air, in a wall-mounted housing, three-phase 4 kW, 400 V AC, Protection class IP 54, 8 A	600 x 600 x 210	all ProtecTor air curtains AC, 2 ProtecTor Door Air Curtains	196003231200
	KaControl control electronics	Recirculating air EC, in a wall-mounted housing, 230 V AC	240 x 190 x 90	all ProtecTor air curtains EC, 2 ProtecTor Door Air Curtains	196003231160
Control accessories electromechanical 230 V					
	Speed controller	continuously variable fan operation, 0-100% presettable, 230 V AC, 10 V, 0-100%, On/Off via room thermostat, surface-mounted protection class IP 54, flush-mounted protection class IP 44	82 x 82 x 68	EC units electromechanical, 2 ProtecTor Door Air Curtains, 5 UniLine or Tandem Door Air Curtains, 10 TOP or Ultra Unit Heaters, 10 Venkon Fan Coils, 2 KaCool D AF or KaCool W Fan Coils	196000030510

CONTINUED ▶

Accessories

Article	Article	Properties	Dimensions [mm]	Suitable for	Article no.
Stage switch and controls for speed regulation					
	2-stage, 3-phase switch	with connection for room thermostat, without connection option for valve actuator, recirculating air-only, 10 A	122 x 130 x 171	Unit heater/door air curtain 400 V three-phase AC motor	196000030049
	5-stage 3-phase controller	4 A ProtecTor **66 up to L = 4000 mm	260 x 180 x 340	Unit heater/door air curtain 400 V three-phase AC motor	196000030752
		8 A	330 x 170 x 380	Unit heater/door air curtain 400 V three-phase AC motor	196000030754
Thermostats					
	Industrial thermostat	with setpoint adjustment by tool, Protection class IP 54	113 x 71 x 158	Unit Heaters, ProtecTor Door Air Curtains, Galaxis Radiant Ceiling Panels	196000030058
	Industrial thermostat	with setpoint adjustment using a dial, Protection class IP 54	113 x 71 x 158	Unit Heaters, ProtecTor Door Air Curtains, Galaxis Radiant Ceiling Panels	196000030059
Control accessories					
	Door contact switch	solid mechanical design, potential-free NC and NO contact	40 x 60 x 135	ProtecTor Door Air Curtains	196000030763
Repair switch					
	Repair switch	AC, Enables individual units in a switching group to be decommissioned by voltage disconnection. The thermal contacts are bridged in advance, and subsequently opened on the motor side so that the other units in the group can continue to operate without interruption., Protection class IP 55, 25 A, supplied separately	82 x 127 x 82	all Unit heaters / Air curtains	196000030120

CONTINUED ▶

Accessories

Article	Article	Properties	Dimensions [mm]	Suitable for	Article no.
---------	---------	------------	--------------------	--------------	-------------

Air outlets

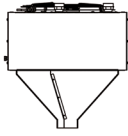
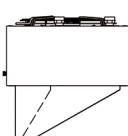
	Discharge nozzle, send-zimir galvanized	Central discharge model A discharge nozzle is essential for every ProtecTor door air curtain! They can also be powder coated in a RAL colour of your choice at a surcharge.	392 x 715 x 1978	Length 2000 mm, Depth 740 mm, Height 360 mm	255000200060
			392 x 715 x 2978	Length 3000 mm, Depth 740 mm, Height 360 mm	255000300060
			392 x 715 x 3978	Length 4000 mm, Depth 740 mm, Height 360 mm	255000400060
			392 x 715 x 4978	Length 5000 mm, Depth 740 mm, Height 360 mm	255000500060
			392 x 815 x 1978	Length 2000 mm, Depth 840 mm, Height 360 mm	255000200070
			392 x 815 x 2978	Length 3000 mm, Depth 840 mm, Height 360 mm	255000300070
			392 x 815 x 3978	Length 4000 mm, Depth 840 mm, Height 360 mm	255000400070
			392 x 815 x 4978	Length 5000 mm, Depth 840 mm, Height 360 mm	255000500070
	Discharge nozzle, send-zimir galvanized	monodirectional outlet, outlet nozzle facing the doorway, with wide air stream to target air stream, A discharge nozzle is essential for every ProtecTor door air curtain! They can also be powder coated in a RAL colour of your choice at a surcharge.	392 x 715 x 1978	Length 2000 mm, Depth 740 mm, Height 360 mm	255000201060
			392 x 715 x 2978	Length 3000 mm, Depth 740 mm, Height 360 mm	255000301060
			392 x 715 x 3978	Length 4000 mm, Depth 740 mm, Height 360 mm	255000401060
			392 x 715 x 4978	Length 5000 mm, Depth 740 mm, Height 360 mm	255000501060
			392 x 815 x 1978	Length 2000 mm, Depth 840 mm, Height 360 mm	255000201070
			392 x 815 x 2978	Length 3000 mm, Depth 840 mm, Height 360 mm	255000301070
			815 x 392 x 3978	Length 4000 mm, Depth 840 mm, Height 360 mm	255000401070
			392 x 815 x 4978	Length 5000 mm, Depth 840 mm, Height 360 mm	255000501070

Kampmann.co.uk/protector

Subject to technical changes. 407/06.2021 UK

Kampmann GmbH & Co. KG
Friedrich-Ebert-Str. 128–130
49811 Lingen (Ems), Germany

T +49 591 7108-0
F +49 591 7108-300
E info@kampmann.de

Kampmann UK Ltd.
Dial House, Govett Avenue
Shepperton, Middlesex, TW17 8AG
Great Britain

T +44 (0)1932 228592
F +44 (0)1932 228949
E info@kampmann.co.uk
W Kampmann.co.uk

