



▶ **Ultra**
Unit heaters

Ultra

Ceiling-mounted unit for heating, cooling and ventilation in large, high-end interiors

▶ **Technical catalogue**

Contents

01 ▶ Product information	6
▶ Overview	7
▶ Product data	8
▶ Selection guide	9
▶ Ultra at a glance	10
02 ▶ Technical data	12
▶ General	13
▶ Ultra - Unit design Heating, Model size 73	14
▶ Ultra - Unit design Heating, Model size 84	16
▶ Ultra - Unit design Heating or cooling, Model size 84	18
▶ Ultra - Unit design Heating, Model size 85	20
▶ Ultra - Unit design Heating or cooling, Model size 85	22
▶ Ultra - Unit design Heating, Model size 96	24
▶ Ultra - Unit design Heating or cooling, Model size 96	26
03 ▶ Design information	28
▶ Types of installation – recirculating air installation	29
▶ Information on planning and design	30
▶ Hybrid ECO System	35
▶ Combination example: two Ultra units with KaCompact ventilation unit	36
04 ▶ Control	38
▶ Control of Ultra – electromechanical model	39
▶ Control of Ultra – KaControl model	49
▶ KaControl – integration into intelligent building networks (IoT)	55
▶ KaControl – system controller	56
05 ▶ Ordering information	58
▶ Ultra	58
▶ Accessories	60



Ultra: Ceiling-mounted unit for heating, cooling, ventilation in large, high-end interiors. Meets the most exacting demands in terms of design and comfort.



ILLENBERGER Steinmetz GmbH,
Nattheim – Steinweiler
Stone masonry firm with a wide product
range and forward-looking approach.

01 ▶ Product information



Ultra – For greater energy efficiency and comfort in large spaces

Kampmann Ultra with EC fans are high-performance, energy-saving and ErP-compliant.

The Ultra is now equipped with the most energy-efficient drive concept through the use of EC technology, and can now be used wherever energy needs to be saved over the long term.

Ultra are used as ceiling-mounted units, either as heating and / or cooling models, for recirculating air or primary air operation in:

- ▶ retail chains
- ▶ showrooms and shop floors
- ▶ entrance halls
- ▶ retail stores with add-on accessories for installation in raised ceilings and acoustic grid ceilings 625 x 625 mm (600 x 600 mm on request)
- ▶ spaces with a ceiling height of between 2.3 m and 4.0 m

The Ultra product range includes 4 models for heating and 3 models for heating / cooling. The height of every model is only 330 mm.

Different heat exchangers and fans are fitted depending on the size (73, 84, 85, 96) and model (heating or heating/cooling) (refer to "Selection guide" on page 9).

Operating principle

Air is drawn in through the axial fan and is blown through the circular heat exchanger into the room. The heated or cooled air is guided into the room on-demand through the pre(settable) louvre slats. Models with large heat exchanger capacity are ideal for use with low water temperatures.

Scope of delivery

- ▶ intake crown for air intake supplied as standard for ease of fitting on site; brackets are fitted
- ▶ 6-sided air outlet, slats can be pre-set at six defined angles

Heating example

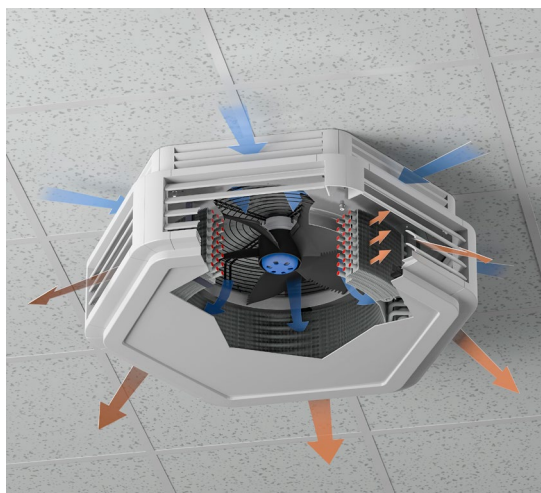

Cooling example



Product data



Product benefits

- ▶ Minimal height due to circular heat exchanger
- ▶ Hexagonal housing design for optimum air distribution for heating and cooling
- ▶ Whisper-quiet sickle-blade fan with energy-efficient EC technology complies with ErP requirements
- ▶ Identical design of unit for recirculation air, mixed air or primary air mode, whether heating or cooling units
- ▶ All housing parts in plastic, therefore less weight, traffic white RAL 9016 (can be coated)
- ▶ Eurokonus valve connection - hygiene-certified to VDI 6022
- ▶ Electro-mechanical control or KaControl system possible
- ▶ Possible integration into KaControl networks or building automation systems, like BACnet, Modbus or LON
- ▶ Hybrid ECO system module for decentralised temperature control



Features

- ▶ Plastic housing in RAL 9016
- ▶ Supplied as standard with intake crown
- ▶ Air guidance slats can be engaged in six positions
- ▶ Continuously variable single-phase EC motor
- ▶ Extensive range of control accessories

Installation	▶ Ceiling-mounted
Air stream	▶ Recirculating air ▶ Mixed air and primary air (on request)
Heating	▶ LPHW
Cooling	▶ CHW ▶ Refrigerants (on request)
Hybrid Eco	▶ In conjunction with primary or secondary air spigots, on request
KaControl	▶ Optional

Performance data

Heat output [kW]¹⁾	▶ 6.0 – 53.6
Cooling output [kW]²⁾	▶ 3.0 – 18.1
Sound pressure level [dB(A)]³⁾	▶ < 20 – 64
Sound power level [dB(A)]	▶ < 28 – 80
Choice of the installation site	▶ copper/aluminium

¹⁾ at LPHW 75/65 °C, $t_{r1} = 20$ °C

²⁾ at CHW 7/12 °C, $t_{r1} = 27$ °C, 48% relative humidity

³⁾ The sound pressure levels were calculated with an assumed room insulation of 16 dB(A). This corresponds to a distance of 3 m, a room volume of 2000 m³ and a reverberation time of 1.0 s (in accordance with VDI 2081).

Operating limits

- ▶ Max. operating pressure: 16 bar
- ▶ Max. entering water temperature: 90 °C
- ▶ Min. entering water temperature: 35 °C
- ▶ Inlet air temperature: 40 °C
- ▶ Max. glycol volume: 50 %

Applications

Buildings of all kinds, which are to be ideally heated and ventilated with centralised or decentralised control.



Selection guide

Fan version	Model size	Width (A) [mm]	Dimensions Depth (B) [mm]	Height (C) [mm]	Heat exchanger model copper/aluminium			Air flow [m ³ /h]
					Heat output ¹⁾ [kW]	Cooling output ²⁾ [kW]	Cooling output ³⁾ [kW]	
EC fan, 230 V, high speed	73	840	750	330	6.5 – 15.9	---	---	590 – 1500
	84	1004	900		6.0 – 20.5	3.0 – 7.5	1.4 – 3.7	500 – 1860
	85				7.4 – 33.2	3.7 – 12.0	1.7 – 5.7	520 – 2970
					10.2 – 53.6	5.1 – 18.1	2.2 – 8.7	680 – 5620
EC fan, 230 V, reduced speed	96	1177	1050		8.2 – 40.1	4.2 – 14.0	1.6 – 6.7	440 – 3930

¹⁾ at LPHW 75/65 °C, $t_{l1} = 20$ °C

²⁾ at CHW 7/12 °C, $t_{l1} = 27$ °C, 48% relative humidity

³⁾ at CHW 16/18, $t_{l1} = 27$ °C, 48% relative humidity

Technical drawing (Dimensions in mm)

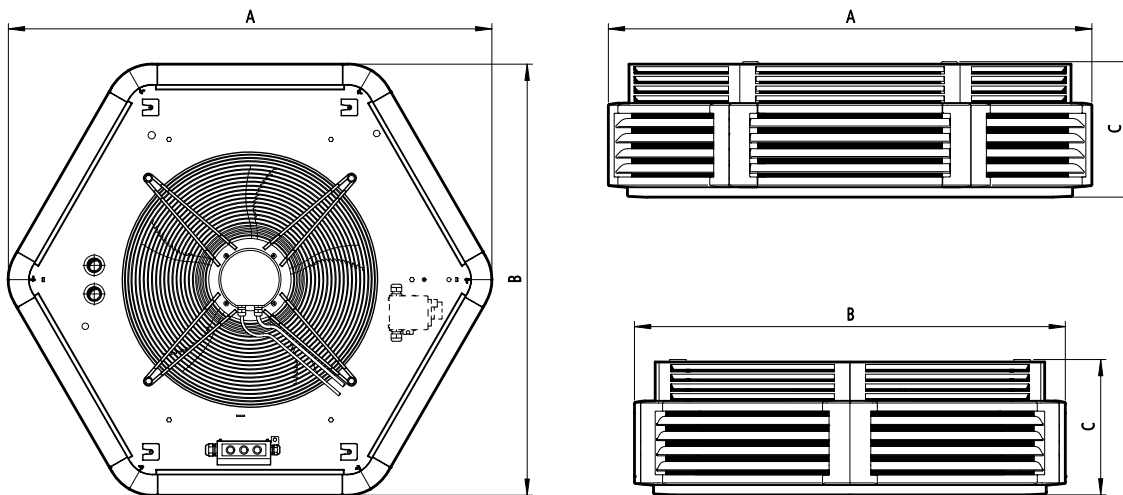

Ultra at a glance



VDI 6022
Conformity
confirmed

Features

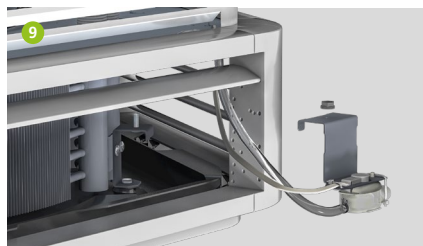
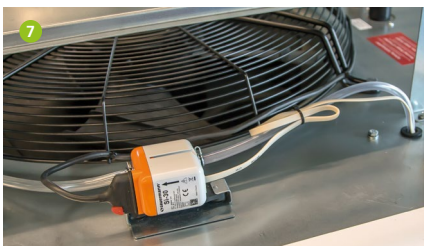
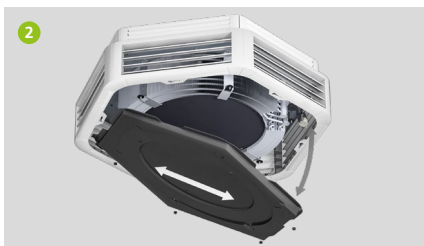

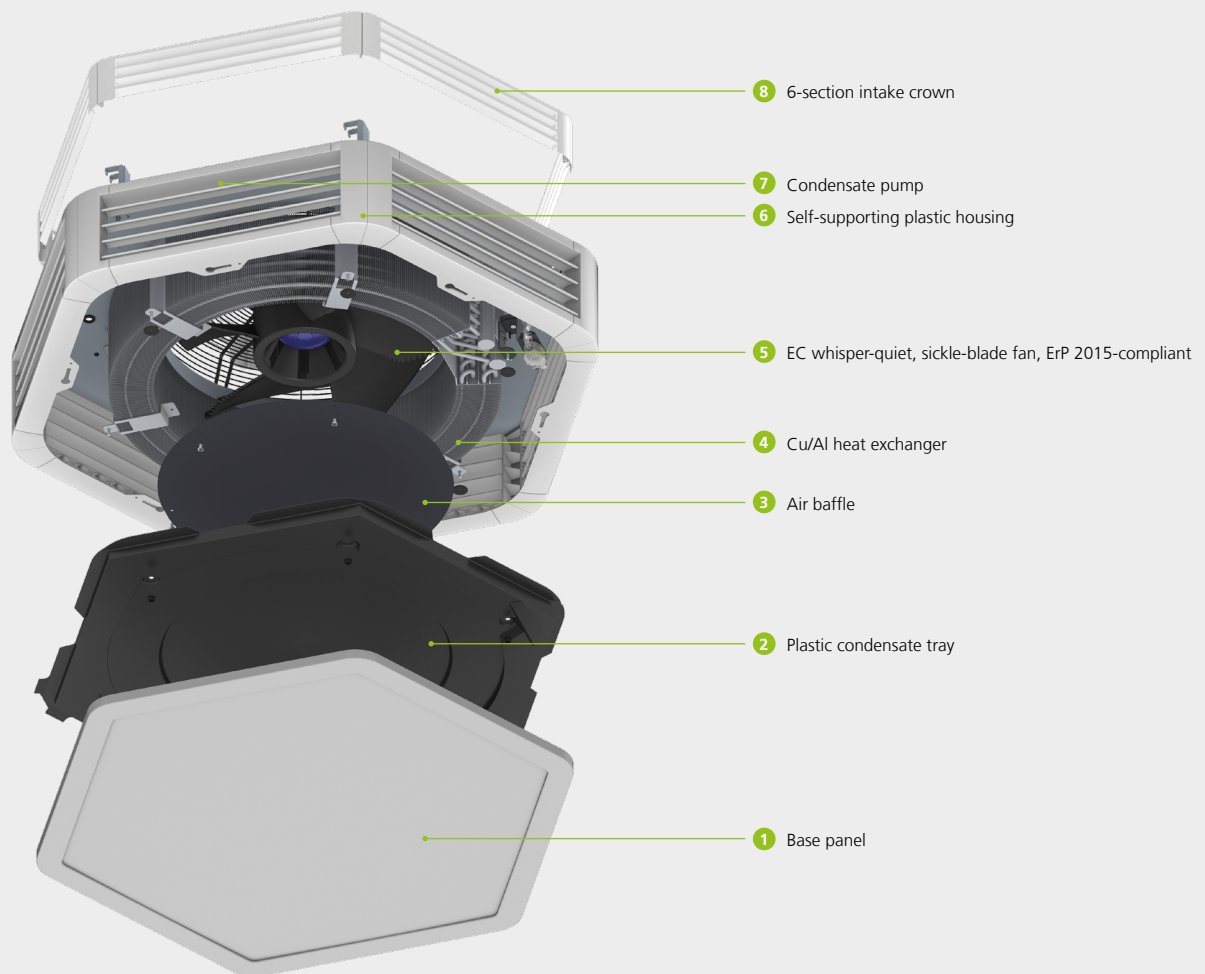
**1 Base panel**

- ▶ easily removable for maintenance

2 Plastic condensate tray

- ▶ maintenance-friendly, thanks to external pump sump with outlet spigots
- ▶ simply dismantled by means of plug-in quick fixing mechanism

3 Air baffle

- ▶ for optimum flow through the heat exchanger

4 Heat exchanger

- ▶ consists of round copper tubes in a circular design with aluminium fins bonded by expansion
- ▶ steel collector and manifold, corrosion-proof, suitable for LPHW up to 90 °C and 16 bar continuous operating pressure
- ▶ connections through the top of the unit
- ▶ suitable for low water temperature heating systems

5 EC whisper-quiet, sickle-blade fan, ErP 2015-compliant:

- ▶ continuously variable EC single-phase whisper-quiet sickle-blade fan
- ▶ excellent efficiency due to the aerodynamic design of the blade geometry
- ▶ motor protection: IP 54
- ▶ balanced at 2 levels; balancing quality according to G 6, 3 DIN ISO 1940 part 1
- ▶ external rotor motor integrated in the fan impeller
- ▶ complies with the ErP Directive (EU) 327/2011 ("LOT 11")

6 Self-supporting plastic housing

- ▶ traffic white RAL 9016
- ▶ with 6-sided air outlet
- ▶ 45 mm wide air flow fins, pre-adjustable to six defined setting angles

7 Condensate pump

- ▶ pre-assembled in the factory with the heating / cooling model

8 6-section intake crown

- ▶ easy to fit

9 Pump sump with float switch easily accessible through the discharge grille

02 ▶ Technical data

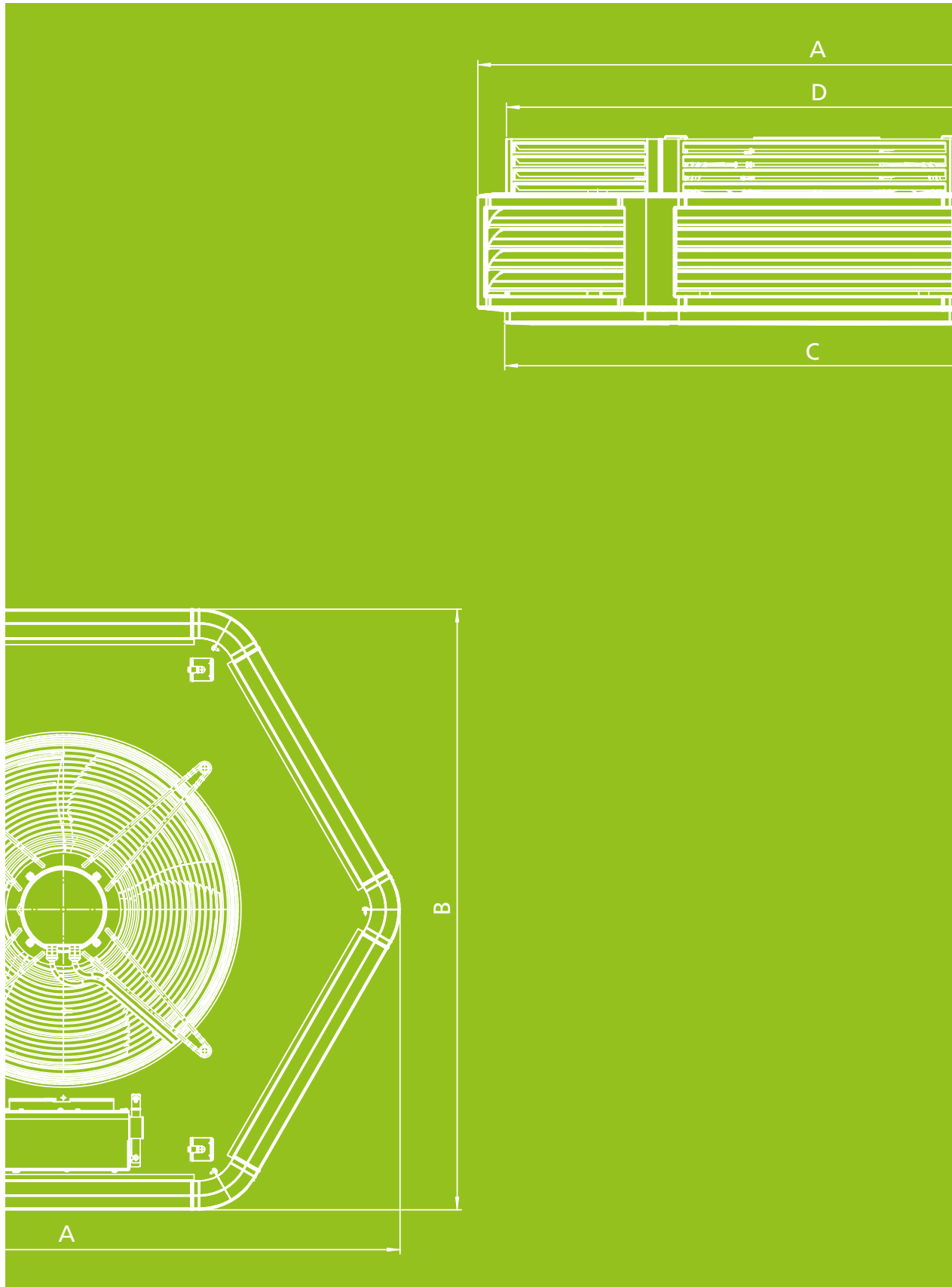

General

EU Directive 2009/125/EU

Compliance with the ErP Directive 2015

The European Commission's ErP Directive ("Energy-related Products") evaluates and modifies the requirements of technical products in energy-related applications.

According to the Directive (EU) 327/2011 ("LOT 11"), the efficiency requirements have become more stringent for fans with an electric drive output of 125 watts to 500 kilowatts. A number of fans can no longer be marketed since the second stage entered into force on 1st January 2015.

The inlet nozzle used in the unit must be taken into account along with the fan, in terms of energy. The Ultra range of unit heaters is solely fitted with ErP-compliant fans. The conformity of the Ultra range has been laboratory-tested and proved. The measurements can be provided on request.

The Ultra range and the components used with it are produced and tested in line with the applicable state of the art. The requirements of the applicable standards, e.g. Machinery Directive, EN 60335 (Safety of Electrical Equipment) and EMC are all met.

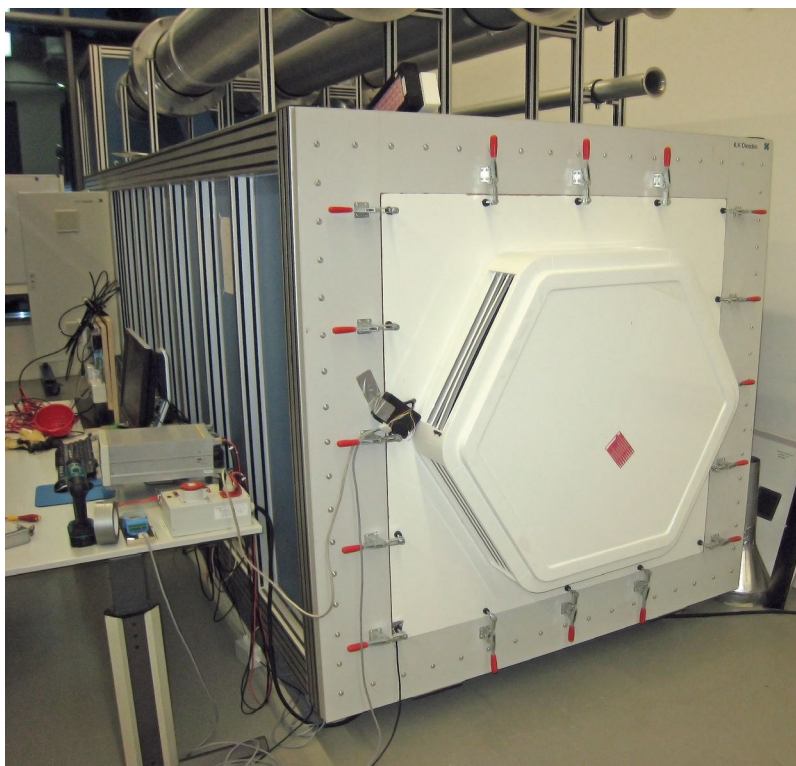

Test chamber for air performance measurements according to DIN EN ISO 5801, Kampmann R & D Centre (FEC)

Ultra

Unit design Heating

Model size 73

EC fan, 230 V, high speed

Technical drawing (Dimensions in mm)

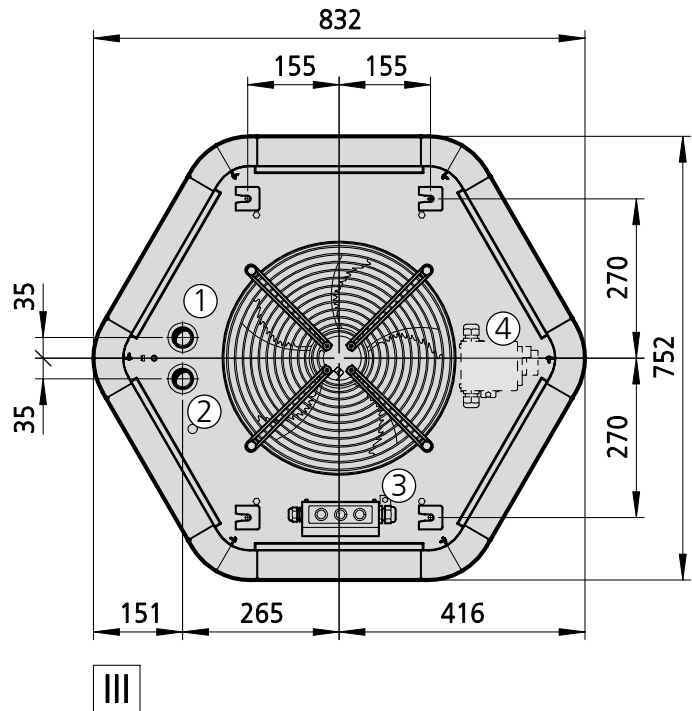
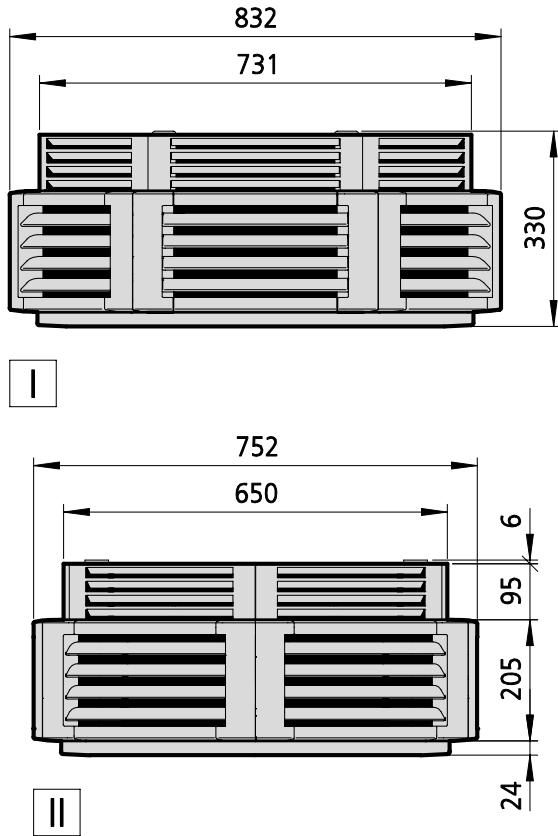

View

- I Front view
- II Side view
- III Top view

More information

- ① Flow
- ② Return
- ③ Electrical connection for EC model, electromechanical
- ④ Repair switch (optional)

Specifications

Fan version	Type	Weight [kg]	Water content [l]	Connection
EC fan, 230 V, high speed	732058	21	1.6	1"
	733058	24	2.3	1"

Performance data

Type	Control voltage	Heat output		Cooling output, total				Air flow	Nominal fan speed	Power consumption	Amperage	Sound pressure level ¹⁾	Sound power level	Throw	Max. mounting height
		at LPHW 75/65 °C, t _{l,i} = 20 °C	at CHW 7/12 °C, t _{l,i} = 27 °C, 48% relative humidity	at CHW 7/12 °C, t _{l,i} = 27 °C, 48% relative humidity	at CHW 16/18, t _{l,i} = 27 °C, 48% relative humidity	[kW]	[°C]								
	[V]	[kW]	[°C]	[kW]	[°C]	[kW]	[°C]	[m³/h]	[1/min]	[W]	[A]	[dB(A)]	[dB(A)]	[m]	[m]
732058	10	12.6	45.5	---	---	---	---	1500	940	48	0.5	44	60	4.5	2.5
	8	11.3	46.7	---	---	---	---	1270	795	29	0.3	40	56	4.0	2.4
	6	9.8	48.2	---	---	---	---	1050	650	17	0.2	35	51	3.5	2.4
	4	8.2	50.0	---	---	---	---	820	505	10	0.1	29	45	3.1	2.3
	2	6.5	51.4	---	---	---	---	600	365	7	0.1	23	39	2.6	2.2
733058	10	15.9	52.9	---	---	---	---	1460	940	48	0.5	42	58	4.3	2.5
	8	14.1	54.2	---	---	---	---	1240	795	29	0.3	38	54	3.9	2.4
	6	12.1	55.7	---	---	---	---	1020	650	17	0.2	33	49	3.5	2.4
	4	10.0	57.6	---	---	---	---	800	505	10	0.1	27	43	3.1	2.3
	2	7.8	59.0	---	---	---	---	590	365	7	0.1	21	37	2.7	2.2

Use our calculation tools on our website to easily calculate heat outputs and other technical data with just a few clicks!

► <https://www.kampmann.co.uk/hvac/products/unit-heaters/ultra#Calculate-performance-data>

¹⁾ The sound pressure levels were calculated with an assumed room insulation of 16 dB(A). This corresponds to a distance of 5 m, a room volume of 3000 m³ and a reverberation time of 2.0 s (in accordance with VDI 2081).

Ultra

Unit design Heating

Model size 84

EC fan, 230 V, high speed

Technical drawing (Dimensions in mm)

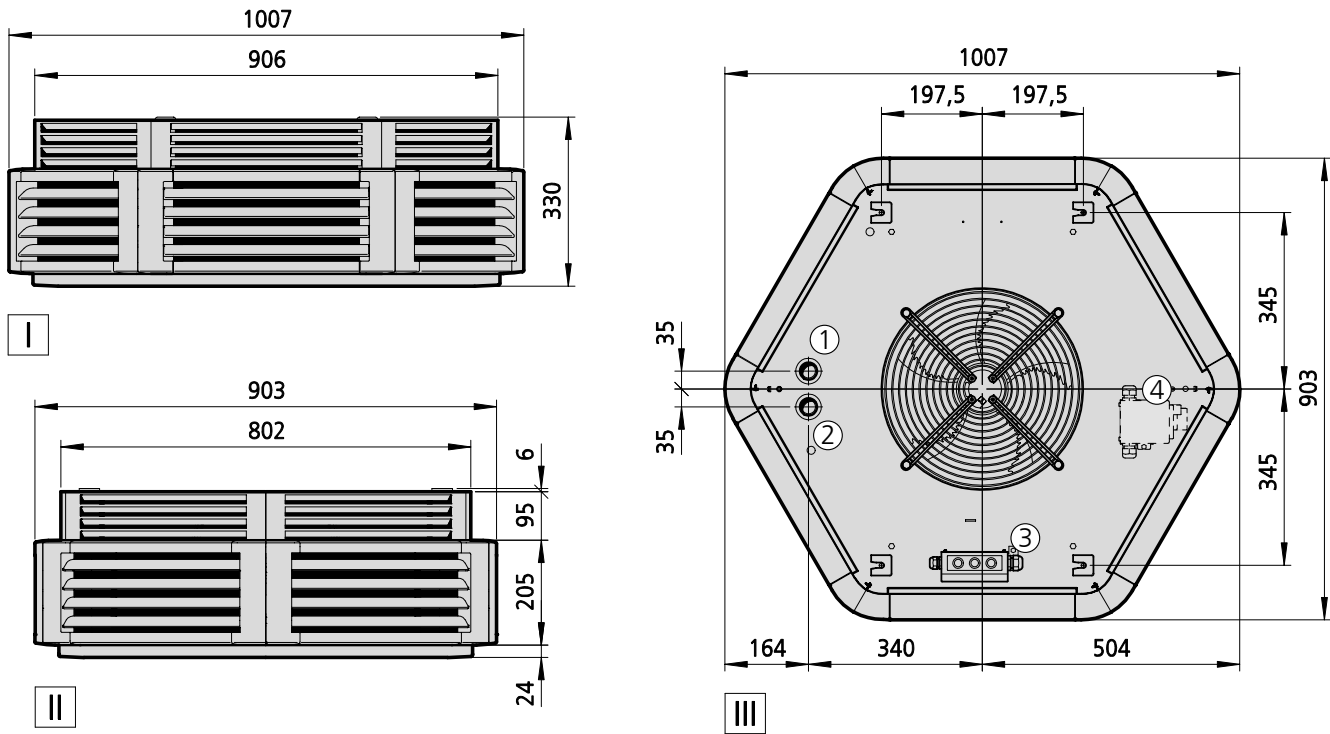

View

- I Front view
- II Side view
- III Top view

More information

- ① Flow
- ② Return
- ③ Electrical connection for EC model, electromechanical
- ④ Repair switch (optional)

Specifications

Fan version	Type	Weight [kg]	Water content [l]	Connection
EC fan, 230 V, high speed	842058	26	1.6	1"
	843058	29	2.3	1"

Performance data

Type	Control voltage	Heat output		Cooling output, total				Air flow	Nominal fan speed	Power consumption	Amperage	Sound pressure level ¹⁾	Sound power level	Throw	Max. mounting height
		at LPHW 75/65 °C, t _{l,i} = 20 °C	at CHW 7/12 °C, t _{l,i} = 27 °C, 48% relative humidity	at CHW 7/12 °C, t _{l,i} = 27 °C, 48% relative humidity	at CHW 16/18, t _{l,i} = 27 °C, 48% relative humidity	[kW]	[°C]								
	[V]	[kW]	[°C]	[kW]	[°C]	[kW]	[°C]	[m ³ /h]	[1/min]	[W]	[A]	[dB(A)]	[dB(A)]	[m]	[m]
842058	10	15.7	45.4	---	---	---	---	1860	1070	70	0.7	48	64	4.9	2.9
	8	14.4	46.2	---	---	---	---	1660	950	39	0.5	44	60	4.5	2.8
	6	11.8	47.8	---	---	---	---	1280	730	21	0.3	37	53	3.5	2.6
	4	8.8	50.6	---	---	---	---	870	490	11	0.1	28	44	2.5	2.4
	2	6.0	52.2	---	---	---	---	510	280	7	0.1	20	35	1.6	2.2
843058	10	20.5	54.2	---	---	---	---	1810	1070	70	0.7	46	62	4.8	2.8
	8	18.7	55.1	---	---	---	---	1610	950	39	0.5	42	58	4.3	2.7
	6	15.2	56.9	---	---	---	---	1240	730	21	0.3	35	51	3.4	2.6
	4	11.1	59.6	---	---	---	---	840	490	11	0.1	26	42	2.4	2.4
	2	7.2	61.3	---	---	---	---	500	280	7	0.1	20	33	1.6	2.3

Use our calculation tools on our website to easily calculate heat outputs and other technical data with just a few clicks!

► <https://www.kampmann.co.uk/hvac/products/unit-heaters/ultra#Calculate-performance-data>

¹⁾ The sound pressure levels were calculated with an assumed room insulation of 16 dB(A). This corresponds to a distance of 5 m, a room volume of 3000 m³ and a reverberation time of 2.0 s (in accordance with VDI 2081).

Ultra

Unit design Heating or cooling

Model size 84

EC fan, 230 V, high speed

Technical drawing (Dimensions in mm)

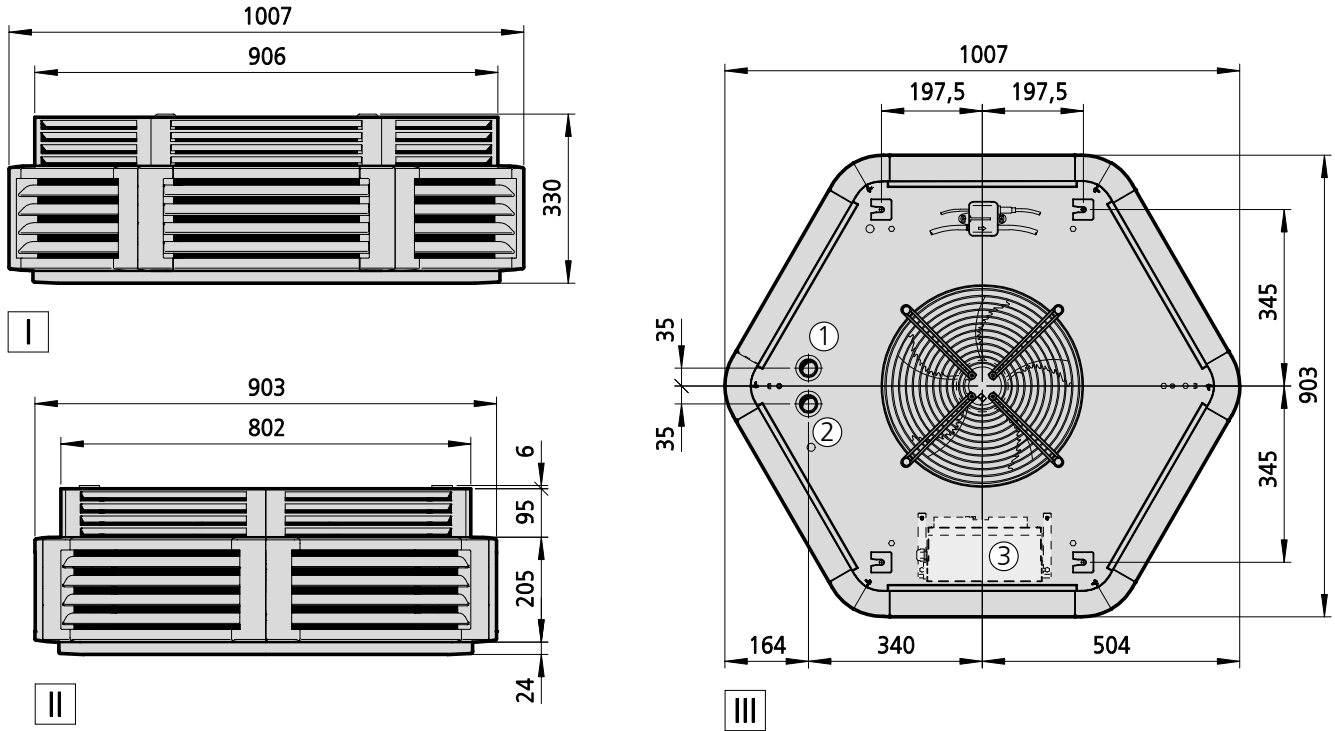

- View**
- I Front view
 - II Side view
 - III Top view

- More information**
- ① Flow
 - ② Return
 - ③ Electrical connection for EC model with KaControl (optional)

Specifications

Fan version	Type	Weight [kg]	Water content [l]	Connection
EC fan, 230 V, high speed	843158	33	2.9	1"

Performance data

Type	Control voltage	Heat output		Cooling output, total				Air flow	Nominal fan speed	Power consumption	Amperage	Sound pressure level ¹⁾	Sound power level	Throw	Max. mounting height
		at LPHW 75/65 °C, t _{l,i} = 20 °C	at CHW 7/12 °C, t _{l,i} = 27 °C, 48% relative humidity	at CHW 7/12 °C, t _{l,i} = 27 °C, 48% relative humidity	at CHW 16/18, t _{l,i} = 27 °C, 48% relative humidity	[kW]	[°C]								
	[V]	[kW]	[°C]	[kW]	[°C]	[kW]	[°C]	[m³/h]	[l/min]	[W]	[A]	[dB(A)]	[dB(A)]	[m]	[m]
843158	10	20.5	54.1	7.5	17.2	3.7	20.7	1810	1070	70	0.7	46	62	4.8	2.8
	8	18.7	55.0	6.9	16.9	3.4	20.4	1610	950	39	0.5	42	58	4.3	2.7
	6	15.2	56.8	5.7	16.3	2.8	20.0	1240	730	21	0.3	35	51	3.4	2.6
	4	11.1	59.6	4.3	15.2	2.1	19.3	840	490	11	0.1	26	42	2.4	2.4
	2	7.2	61.3	3.0	14.6	1.4	18.9	500	280	7	0.1	20	33	1.6	2.3

Use our calculation tools on our website to easily calculate heat outputs and other technical data with just a few clicks!

► <https://www.kampmann.co.uk/hvac/products/unit-heaters/ultra#Calculate-performance-data>

¹⁾ The sound pressure levels were calculated with an assumed room insulation of 16 dB(A). This corresponds to a distance of 5 m, a room volume of 3000 m³ and a reverberation time of 2.0 s (in accordance with VDI 2081).

Ultra

Unit design Heating

Model size 85

EC fan, 230 V, high speed

Technical drawing (Dimensions in mm)

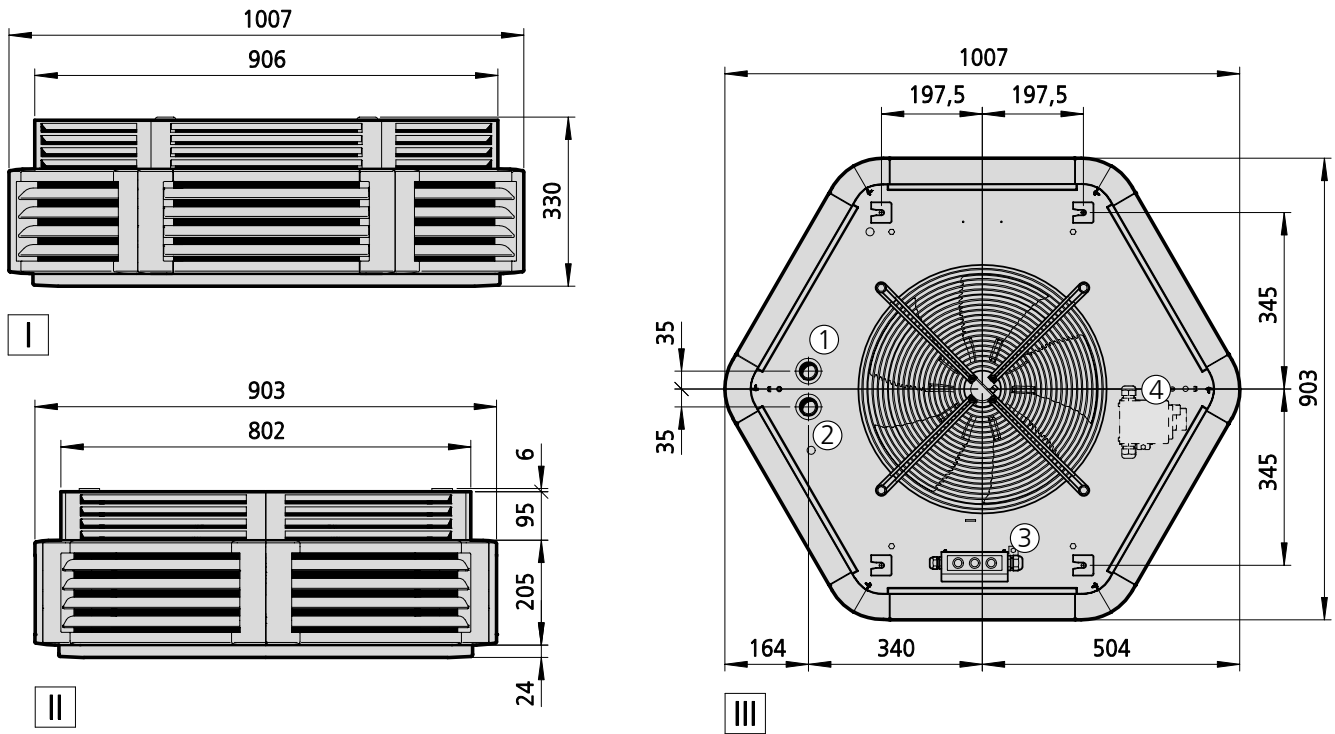

- View**
- I Front view
 - II Side view
 - III Top view

- More information**
- ① Flow
 - ② Return
 - ③ Electrical connection for EC model, electromechanical
 - ④ Repair switch (optional)

Specifications

Fan version	Type	Weight [kg]	Water content [l]	Connection
EC fan, 230 V, high speed	852058	28	2.0	1"
	853058	30	2.9	1"
	854058	33	3.8	1"

Performance data

Type	Control voltage	Heat output		Cooling output, total				Air flow	Nominal fan speed	Power consumption	Amperage	Sound pressure level ¹⁾	Sound power level	Throw	Max. mounting height
		at LPHW 75/65 °C, t _{l,r} = 20 °C	at CHW 7/12 °C, t _{l,r} = 27 °C, 48% relative humidity	at CHW 16/18, t _{l,r} = 27 °C, 48% relative humidity	at CHW 16/18, t _{l,r} = 27 °C, 48% relative humidity	[kW]	[°C]								
	[V]	[kW]	[°C]	[kW]	[°C]	[kW]	[°C]	[m³/h]	[1/min]	[W]	[A]	[dB(A)]	[dB(A)]	[m]	[m]
852058	10	21.7	42.0	---	---	---	---	2970	1070	165	1.5	56	72	5.7	3.4
	8	19.7	42.7	---	---	---	---	2620	950	95	1.0	53	69	5.3	3.3
	6	15.9	44.4	---	---	---	---	1970	730	46	0.6	45	61	4.6	3.0
	4	11.5	47.4	---	---	---	---	1270	490	23	0.3	35	51	3.8	2.6
	2	7.4	49.0	---	---	---	---	650	280	12	0.2	23	39	3.0	2.3
853058	10	29.1	50.4	---	---	---	---	2880	1070	165	1.5	54	70	5.6	3.4
	8	26.4	51.3	---	---	---	---	2540	950	95	1.0	51	67	5.2	3.2
	6	21.1	53.2	---	---	---	---	1910	730	46	0.6	43	59	4.5	3.0
	4	14.8	56.4	---	---	---	---	1230	490	23	0.3	33	49	3.7	2.6
	2	9.0	58.3	---	---	---	---	630	280	12	0.2	21	37	3.0	2.4
854058	10	33.2	57.1	---	---	---	---	2700	1070	165	1.5	52	68	5.4	3.3
	8	30.0	58.0	---	---	---	---	2380	950	95	1.0	49	65	5.0	3.2
	6	23.7	60.0	---	---	---	---	1790	730	46	0.6	41	57	4.4	2.9
	4	16.4	63.0	---	---	---	---	1150	490	23	0.3	31	47	3.6	2.6
	2	9.4	64.9	---	---	---	---	580	280	12	0.2	20	35	3.0	2.4

Use our calculation tools on our website to easily calculate heat outputs and other technical data with just a few clicks!
 ▶ <https://www.kampmann.co.uk/hvac/products/unit-heaters/ultra#Calculate-performance-data>

¹⁾ The sound pressure levels were calculated with an assumed room insulation of 16 dB(A). This corresponds to a distance of 5 m, a room volume of 3000 m³ and a reverberation time of 2.0 s (in accordance with VDI 2081).

Ultra

Unit design Heating or cooling

Model size 85

EC fan, 230 V, high speed

Technical drawing (Dimensions in mm)

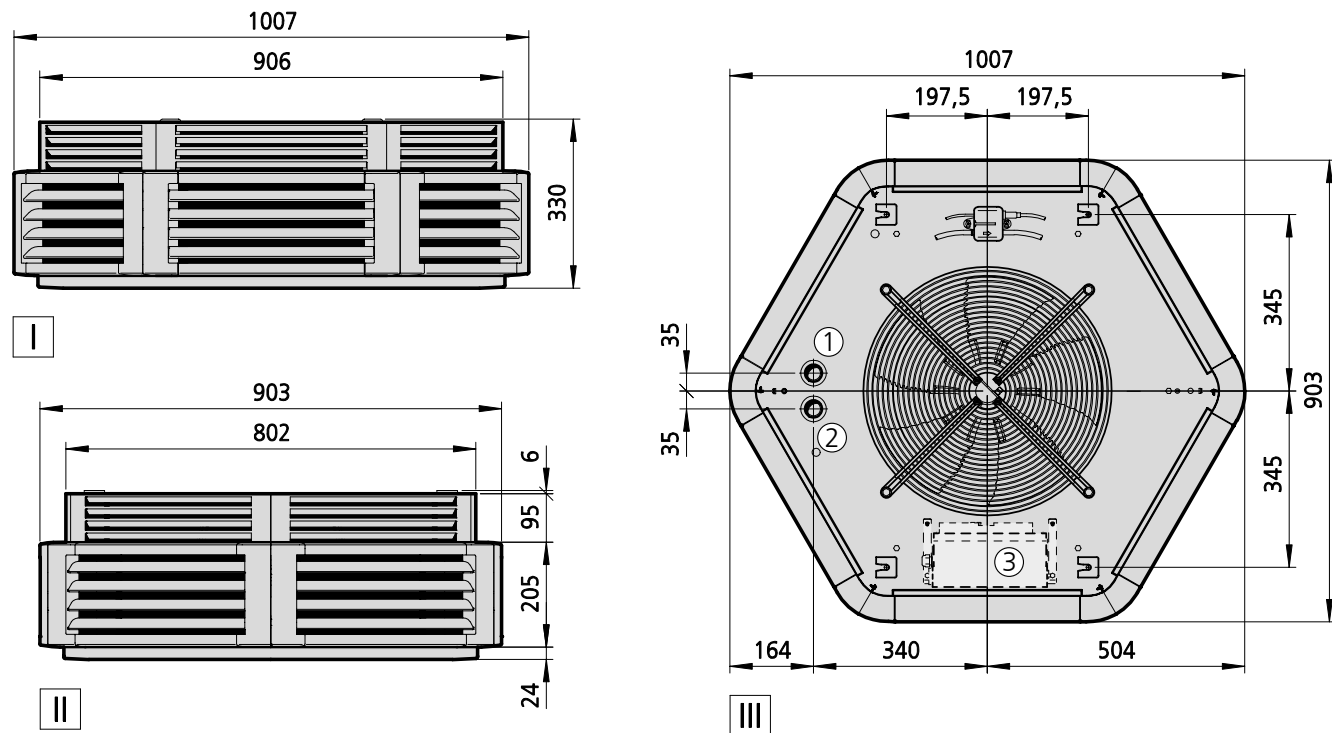

- View**
- I Front view
 - II Side view
 - III Top view

- More information**
- ① Flow
 - ② Return
 - ③ Electrical connection for EC model with KaControl (optional)

Specifications

Fan version	Type	Weight [kg]	Water content [l]	Connection
EC fan, 230 V, high speed	853158	35	2.9	1"
	854158	36	3.8	1"

Performance data

Type	Control voltage	Heat output		Cooling output, total				Air flow	Nominal fan speed	Power consumption	Amperage	Sound pressure level ¹⁾	Sound power level	Throw	Max. mounting height
		at LPHW 75/65 °C, t _{l,r} = 20 °C	at CHW 7/12 °C, t _{l,r} = 27 °C, 48% relative humidity	at CHW 7/12 °C, t _{l,r} = 27 °C, 48% relative humidity	at CHW 16/18, t _{l,r} = 27 °C, 48% relative humidity	[kW]	[°C]								
	[V]	[kW]	[°C]	[kW]	[°C]	[kW]	[°C]	[m ³ /h]	[1/min]	[W]	[A]	[dB(A)]	[dB(A)]	[m]	[m]
853158	10	29.1	50.4	10.1	18.5	5.1	21.5	2880	1070	165	1.5	54	70	5.6	3.4
	8	26.4	51.3	9.2	18.2	4.7	21.3	2540	950	95	1.0	51	67	5.2	3.2
	6	21.1	53.2	7.5	17.5	3.8	20.8	1910	730	46	0.6	43	59	4.5	3.0
	4	14.8	56.4	5.6	16.3	2.8	20.0	1230	490	23	0.3	33	49	3.7	2.6
	2	9.0	58.3	3.7	15.7	1.7	19.6	630	280	12	0.2	21	37	3.0	2.4
854158	10	31.3	58.8	12.0	15.6	5.7	19.8	2430	1070	165	1.5	52	68	4.8	3.2
	8	28.2	59.7	10.9	15.3	5.2	19.5	2140	950	95	1.0	49	65	4.5	3.0
	6	22.3	61.8	8.8	14.5	4.2	19.0	1610	730	46	0.6	41	57	3.9	2.8
	4	15.4	65.1	6.4	13.1	2.9	18.2	1030	490	23	0.3	31	47	3.3	2.6
	2	8.9	67.1	4.2	12.4	1.7	17.7	520	280	12	0.2	20	35	2.7	2.3

Use our calculation tools on our website to easily calculate heat outputs and other technical data with just a few clicks!

► <https://www.kampmann.co.uk/hvac/products/unit-heaters/ultra#Calculate-performance-data>

¹⁾ The sound pressure levels were calculated with an assumed room insulation of 16 dB(A). This corresponds to a distance of 5 m, a room volume of 3000 m³ and a reverberation time of 2.0 s (in accordance with VDI 2081).

Ultra

Unit design Heating

Model size 96

EC fan, 230 V, high speed

Technical drawing (Dimensions in mm)

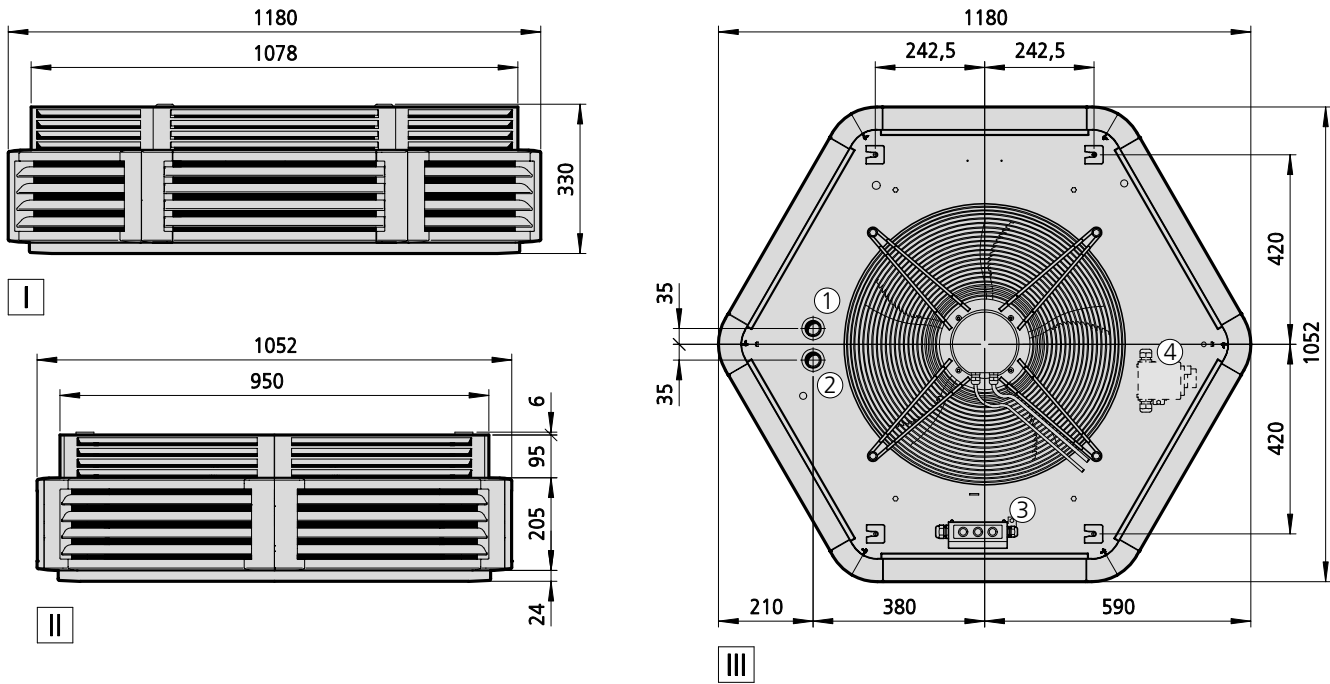

View

- I Front view
- II Side view
- III Top view

More information

- ① Flow
- ② Return
- ③ Electrical connection for EC model, electromechanical
- ④ Repair switch (optional)

Specifications

Fan version	Type	Weight [kg]	Water content [l]	Connection
EC fan, 230 V, high speed	962058	40	2.2	1"
	963058	43	3.3	1"
	964058	45	4.4	1"
EC fan, 230 V, reduced speed	962056	40	2.2	1"
	963056	43	3.3	1"
	964056	45	4.4	1"

Performance data

Type	Control voltage	Heat output		Cooling output, total				Air flow	Nominal fan speed	Power consumption	Amperage	Sound pressure level ¹⁾	Sound power level	Throw	Max. mounting height
		at LPHW 75/65 °C, t _{l,r} = 20 °C	at CHW 7/12 °C, t _{l,r} = 27 °C, 48% relative humidity	at CHW 16/18, t _{l,r} = 27 °C, 48% relative humidity	at CHW 16/18, t _{l,r} = 27 °C, 48% relative humidity	[kW]	[°C]								
	[V]	[kW]	[°C]	[kW]	[°C]	[kW]	[°C]	[m³/h]	[l/min]	[W]	[A]	[dB(A)]	[dB(A)]	[m]	[m]
962056	10	27.1	40.8	---	---	---	---	3930	695	171	0.8	52	68	6.0	4.4
	8	22.7	42.2	---	---	---	---	3080	545	85	0.4	47	63	5.2	4.0
	6	18.0	44.3	---	---	---	---	2240	395	36	0.2	40	56	4.5	3.6
	4	13.2	48.5	---	---	---	---	1400	250	16	0.1	29	45	3.7	3.2
	2	8.2	50.2	---	---	---	---	550	100	8	0.1	20	31	3.0	2.8
962058	10	35.4	39.0	---	---	---	---	5620	990	470	2.1	64	80	7.5	5.1
	8	29.9	40.1	---	---	---	---	4480	790	237	1.1	58	74	6.5	4.6
	6	23.7	41.8	---	---	---	---	3280	580	98	0.5	50	66	5.4	4.1
	4	17.1	44.8	---	---	---	---	2080	370	31	0.2	39	55	4.3	3.5
	2	10.2	46.3	---	---	---	---	880	160	10	0.1	25	41	3.3	3.0
963056	10	36.0	49.3	---	---	---	---	3700	695	171	0.8	50	66	5.8	4.3
	8	29.7	50.8	---	---	---	---	2910	545	85	0.4	45	61	5.1	3.9
	6	23.2	53.1	---	---	---	---	2110	395	36	0.2	38	54	4.4	3.5
	4	16.4	57.6	---	---	---	---	1320	250	16	0.1	27	43	3.6	3.2
	2	9.3	59.5	---	---	---	---	520	100	8	0.1	20	29	2.9	2.8
963058	10	47.6	47.1	---	---	---	---	5300	990	470	2.1	62	78	7.2	5.0
	8	39.9	48.5	---	---	---	---	4230	790	237	1.1	56	72	6.2	4.5
	6	31.2	50.4	---	---	---	---	3100	580	98	0.5	48	64	5.2	4.0
	4	22.0	53.7	---	---	---	---	1960	370	31	0.2	37	53	4.2	3.5
	2	12.1	55.5	---	---	---	---	830	160	10	0.1	23	39	3.2	3.0
964056	10	40.1	56.5	---	---	---	---	3310	695	171	0.8	48	64	5.4	4.1
	8	32.8	58.0	---	---	---	---	2600	545	85	0.4	43	59	4.8	3.8
	6	25.3	60.3	---	---	---	---	1890	395	36	0.2	36	52	4.2	3.4
	4	17.4	64.2	---	---	---	---	1190	250	16	0.1	25	41	3.6	3.1
	2	9.2	66.1	---	---	---	---	480	100	8	0.1	20	28	3.0	2.8
964058	10	53.6	54.1	---	---	---	---	4740	990	470	2.1	60	76	6.7	4.7
	8	44.6	55.6	---	---	---	---	3780	790	237	1.1	54	70	5.8	4.3
	6	34.6	57.6	---	---	---	---	2770	580	98	0.5	46	62	4.9	3.8
	4	23.9	60.8	---	---	---	---	1760	370	31	0.2	35	51	4.1	3.4
	2	12.4	62.6	---	---	---	---	750	160	10	0.1	21	37	3.2	2.9

Use our calculation tools on our website to easily calculate heat outputs and other technical data with just a few clicks!
 ▶ <https://www.kampmann.co.uk/hvac/products/unit-heaters/ultra#Calculate-performance-data>

¹⁾ The sound pressure levels were calculated with an assumed room insulation of 16 dB(A). This corresponds to a distance of 5 m, a room volume of 3000 m³ and a reverberation time of 2.0 s (in accordance with VDI 2081).

Ultra

Unit design Heating or cooling
 Model size 96
 EC fan, 230 V, high speed

Technical drawing (Dimensions in mm)

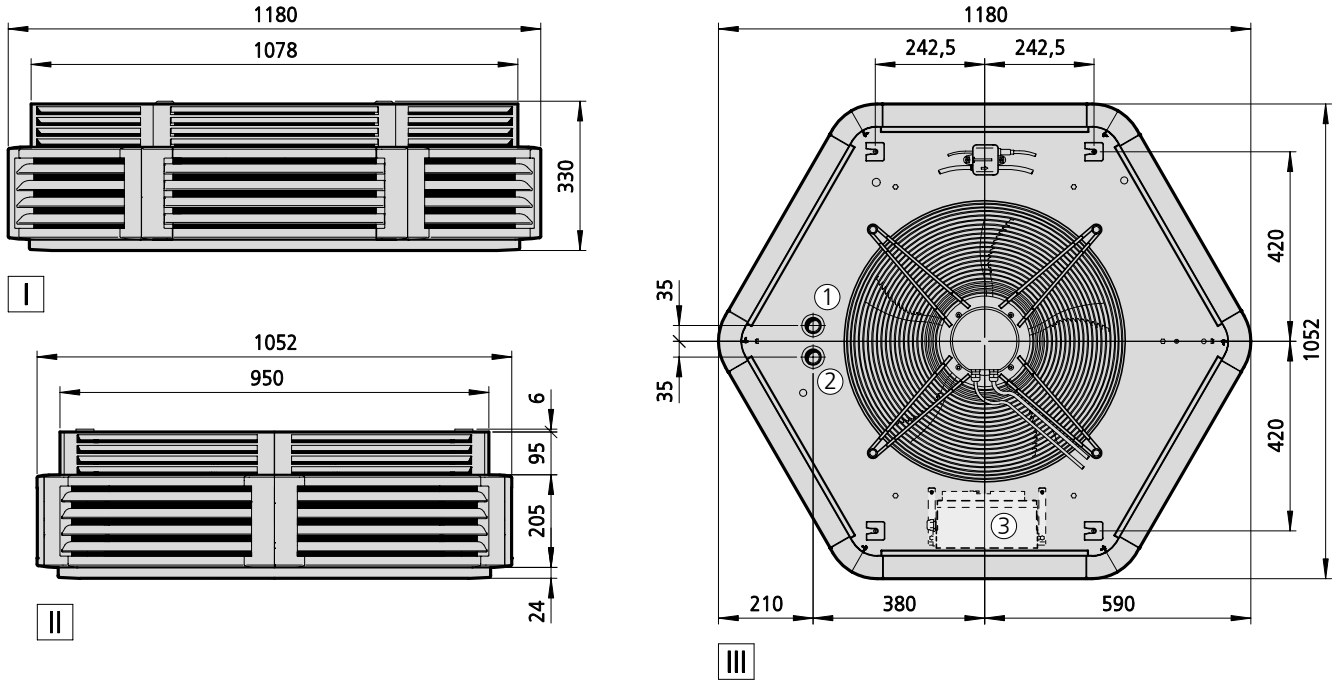

- View**
- I Front view
 - II Side view
 - III Top view

- More information**
- ① Flow
 - ② Return
 - ③ Electrical connection for EC model with KaControl (optional)

Specifications

Fan version	Type	Weight [kg]	Water content [l]	Connection
EC fan, 230 V, high speed	963158	48	3.3	1"
	964158	50	4.4	1"
EC fan, 230 V, reduced speed	963156	48	3.3	1"
	964156	50	4.4	1"

Performance data

Type	Control voltage	Heat output		Cooling output, total				Air flow	Nominal fan speed	Power consumption	Amperage	Sound pressure level ¹⁾	Sound power level	Throw	Max. mounting height
		at LPHW 75/65 °C, t _L = 20 °C	at CHW 7/12 °C, t _L = 27 °C, 48% relative humidity	at CHW 16/18, t _L = 27 °C, 48% relative humidity	[kW]	[°C]	[kW]								
	[V]	[kW]	[°C]	[kW]	[°C]	[kW]	[°C]	[m³/h]	[1/min]	[W]	[A]	[dB(A)]	[dB(A)]	[m]	[m]
963156	10	36.0	49.3	12.2	18.8	6.4	21.6	3700	695	171	0.8	50	66	5.8	3.7
	8	29.7	50.8	10.4	18.3	5.4	21.2	2910	545	85	0.4	45	61	5.1	3.4
	6	23.2	53.1	8.4	17.4	4.3	20.7	2110	395	36	0.2	38	54	4.4	3.2
	4	16.4	57.6	6.4	15.8	3.1	19.7	1320	250	16	0.1	27	43	3.6	3.0
	2	9.3	59.5	4.2	15.2	1.8	19.3	520	100	8	0.1	20	29	2.9	2.7
963158	10	47.6	47.1	15.6	19.6	8.2	22.2	5300	990	470	2.1	62	78	7.2	4.1
	8	39.9	48.5	13.3	19.1	7.0	21.8	4230	790	237	1.1	56	72	6.2	3.8
	6	31.2	50.4	10.8	18.4	5.7	21.3	3100	580	98	0.5	48	64	5.2	3.5
	4	22.0	53.7	8.0	17.2	4.1	20.6	1960	370	31	0.2	37	53	4.2	3.2
	2	12.1	55.5	5.1	16.6	2.3	20.1	830	160	10	0.1	23	39	3.2	2.8
964156	10	36.9	58.5	14.0	15.7	6.7	19.8	2890	695	171	0.8	48	64	4.7	3.4
	8	30.3	60.1	11.8	15.1	5.6	19.4	2280	545	85	0.4	43	59	4.2	3.3
	6	23.3	62.3	9.4	14.2	4.4	18.9	1660	395	36	0.2	36	52	3.7	3.1
	4	16.1	66.2	7.0	12.5	3.0	18.0	1050	250	16	0.1	25	41	3.2	2.9
	2	8.6	68.2	4.5	11.7	1.6	17.6	440	100	8	0.1	20	28	2.7	2.7
964158	10	49.3	56.0	18.1	16.7	8.7	20.4	4130	990	470	2.1	60	76	5.7	3.8
	8	41.1	57.6	15.4	16.1	7.4	20.0	3290	790	237	1.1	54	70	5.1	3.6
	6	31.9	59.7	12.3	15.3	5.9	19.5	2420	580	98	0.5	46	62	4.3	3.3
	4	22.0	62.9	9.0	13.9	4.1	18.7	1550	370	31	0.2	35	51	3.6	3.0
	2	11.6	64.7	5.5	13.2	2.2	18.3	680	160	10	0.1	21	37	2.9	2.8

Use our calculation tools on our website to easily calculate heat outputs and other technical data with just a few clicks!
 ▶ <https://www.kampmann.co.uk/hvac/products/unit-heaters/ultra#Calculate-performance-data>

¹⁾ The sound pressure levels were calculated with an assumed room insulation of 16 dB(A). This corresponds to a distance of 5 m, a room volume of 3000 m³ and a reverberation time of 2.0 s (in accordance with VDI 2081).

03 ▶ Design information



Types of installation – recirculating air installation

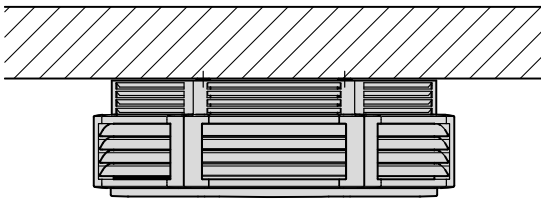

Recirculating air unit with a solid ceiling

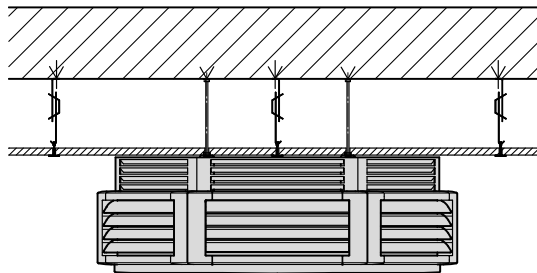

Recirculating air unit with a raised ceiling

Suggested installations – Recirculating air

Example 1: Ultra with recirculating air filter attachment with an open ceiling

Ultra fitted below an open ceiling; recirculating air filter attachment arranged above the unit, air intake through the open ceiling.

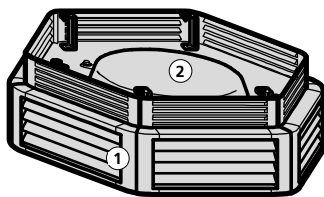

- ① Ultra
- ② recirculating air filter attachment type 6*050

Example 2: Ultra with recirculating air components for installation in a suspended ceiling

Ultra installed below a suspended ceiling; intake air filtered through filter insert in 90° air intake bend; air intake through square recirculating air intake grille, fits acoustic ceiling grids measuring 625 x 625 mm with visible installation rail

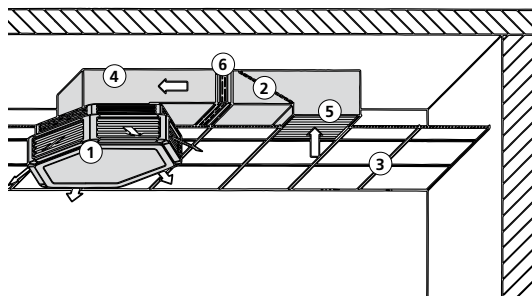

- ① Ultra
- ② filter insert with ISO Coarse 45% filter, type 60126
- ③ acoustic ceiling grid, 625 x 625 mm¹⁾, with visible installation rail
- ④ 90° reducing bend, type 60104
- ⑤ 90° air intake bend with intake grille type 60105
- ⑥ flexible connection, type 6*034

* Insert figure for unit size.

¹⁾ Model for ceiling grid 600 x 600 mm on request.

Information on planning and design

The selection and configuration of the Kampmann Ultra depends on more than just the heat load calculated. The required air circulation, structural and acoustic conditions and unit-specific properties need to be taken into consideration, among other things.

Unit design

The units required are determined using the usual standards and guidelines. Operating a dynamic air handling system with Ultra units is ideal for non-steady state operation. We would recommend allowing a margin to ensure that the heating system is adapted to the specific conditions of use.

Calculating the number, size and design stage of Ultra units is based on the:

- ▶ calculated heat output
- ▶ max. mounting height
- ▶ required air circulation
- ▶ sound levels to be adhered to
- ▶ structural conditions, such as occupied zones, installation points, furniture

Designing the Ultra with EC fan with a control voltage of 6 V has proved itself in practice. This leaves reserves to heat a room up after the units have been switched off for some time and also ensures maximum energy efficiency.

Suspended ceiling installation with acoustic ceilings

Detailed description with examples on *page 29*.

Air circulation

Designing the Ultra based on the air circulation has proved to be very practical to obtain a simplified and reliable unit selection and uniform air distribution. The right gaps between unit heaters can be obtained taking into consideration the maximum mounting height without the need for additional calculations.

$$LU \text{ [1/h]} = \frac{V_{L\text{eff}} \cdot n}{V}$$

LU [1/h] = air circulation at the design stage

$V_{L\text{eff}}$ [m³/h] = effective air volume of the unit at the design stage

V [m³] = room volume

n [-] = number of Ultra units

Air circulation LU [1/h]	
minimum	1.5
better	2.0
good	2.5 - 3.0
very good	3.5 - 4.0

Outlet air temperatures

Air outlet temperatures can be calculated using the following formula:

- ▶ if the use of additional components results in a reduced air volume and thus a lower heat output
- ▶ if a temperature difference Δt between the mean water temperature and the air intake temperature has been selected, which is not shown in the performance tables

$$t_{L2} = t_{L1} + \frac{Q_{\text{eff}} \cdot 1000}{V_{L\text{eff}} \cdot C}$$

- t_{L1} [°C] = inlet air temperature
- t_{L2} [°C] = outlet air temperature
- Q_{eff} [kW] = effective heat output of the Ultra
- $V_{L\text{eff}}$ [kW] = effective heat output of the Ultra (taking into account add-on components)
- C [Wh/m³ K] = multiplier for outlet air temperature calculation

t_{L1}	C	t_{L1}	C
[°C]	[Wh/m ³ K]	[°C]	[Wh/m ³ K]
+ 20	0.34	± 0	0.36
+ 10	0.35	-10	0.37

Guideline values for the outlet air temperature:

- ▶ min. 30 – 35 °C (only go below at high fan speed)
- ▶ max. 50 – 55 °C

If a leaving air temperature of 35°C cannot be reached due to low flow temperatures, adjust the outlet air slats so that the primary air stream does not point directly at the occupied zones. The occupied zones are therefore heated by secondary vortices.

Maximum installation height – throw

The maximum installation height and especially the throw are directly dependent on

- ▶ the shape of the room
- ▶ the over-temperature of the air flow
- ▶ the configuration of the room
- ▶ the air volume
- ▶ the discharge louvre position

The throw of the Ultra is defined as the maximum penetration depth of the primary air stream under ideal conditions. All the maximum mounting heights and throws given in the tables only apply to an entering air temperature of up to 20 K above room temperature.

These values should only be viewed as guideline values, in view of the significant dependency of the throw on the room geometry, equipment and up-current caused by higher outlet temperatures.

Higher room depths are indirectly involved and heated in the air exchange by the secondary vortex.

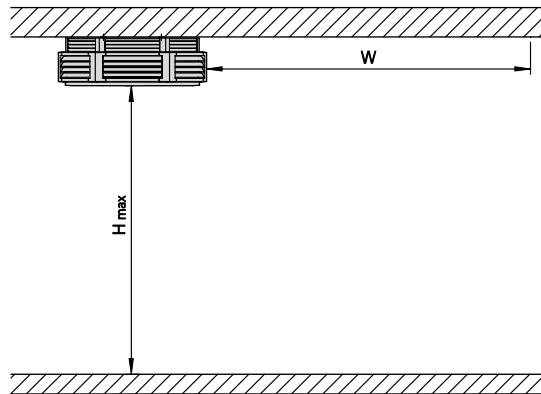

Maximum mounting height (H_{max}) and throw (W)

Maximum mounting height – throws (for more detailed information, refer to the technical data from page 14 onwards)

Ultra series		73__58					84__58					85__58				
Voltage	[V]	10	8	6	4	2	10	8	6	4	2	10	8	6	4	2
Approx. speed	[rpm]	940	795	650	505	365	1070	950	730	490	280	1000	890	700	480	260
Max. mounting height H_{max}	[m]	2.5	2.4	2.4	2.3	2.3	2.9	2.7	2.4	2.4	2.3	3.4	3.2	3.0	2.7	2.4
Throw W	[m]	4.3	3.9	3.5	3.1	2.7	4.8	4.4	3.4	2.4	1.5	5.6	5.2	4.6	3.9	3.1

Ultra series		96__58					96__56				
Voltage	[V]	10	8	6	4	2	10	8	6	4	2
Approx. speed	[rpm]	1000	800	580	370	170	680	550	410	270	100
Max. mounting height H_{max}	[m]	4.1	3.8	3.5	3.2	2.8	3.6	3.4	3.2	3.0	2.7
Throw W	[m]	7.2	6.2	5.2	4.2	3.3	5.7	5.1	4.4	3.8	3.0

Model for cooling mode

This special model is suitable for heating operation with LPHW as well as for cooling operation using CHW. A condensate tray is also integrated in the underside of the unit below the heat exchanger. A collection tank for condensate intake and a float module are positioned in the middle of the tray near the connections and accessible from outside. Only 2 pipes, flow and return, are routed to the Ultra (2-pipe system). A chiller for CHW is required depending on the system. Heating/cooling changeover is triggered centrally (e.g. in the plant room). At this changeover point, the pipework for heating mode is switched to hot water and to cold water for cooling mode. The pipes and fittings must be isolated and laid in accordance with the guidelines for refrigerant lines.

Due to its generously dimensioned basic construction and low basic fan speeds, the cooling model is fundamentally used with air dehumidification.

Nevertheless, specific operating modes and settings need to be taken into account for cooling mode:

- ▶ Never move the louvre slats into the end positions, e.g. to shut off a discharge opening. At high fan speeds, there is otherwise a risk that water droplets could be carried into the other air outlet fields by inadmissibly high air speeds.
- ▶ Only operate unit types 963158 and 964158 at a maximum fan speed of 700 rpm or only with dry cooling.
- ▶ We would recommend the use of valves (e.g. thermoelectric shut-off valve with recirculating mode) to prevent impermissibly severe cooling down of the housing when the fan is at a standstill.

This counteracts the outer parts of the housing experiencing condensate, especially with extreme conditions involving very high levels of humidity.

Condensate pump

The self-priming condensate pump is fixed to the hose connector for the on-site condensate pressurised line. This ultra-quiet, electromagnetically operating pump is mounted on the top of the unit.

Max. delivery height:	8 m with max. 4.5 l/h flow rate and a hose length of 10 m
Max. pump volume:	approx. 18 l/h with 0.5 m delivery height and a hose length of 2 m
Supply voltage:	230 V/50 Hz (separate power line needed)
Power consumption:	14 W
Condensate pressure line:	DN 6 mm (hose connection)
Signal contact for condensate overflow:	Normally closed contact (NC), potential-free switching capacity 250 V/5 A

Condensate pump limits

The achievable flow volume of the condensate pump used depends on the volume of condensate produced in the Ultra and the length of condensate hose connected. The volume of condensate rises and the possible delivery height of the pump falls with extreme air humidity and/or very low system temperatures. Particularly when operating larger Ultra models (series 96), the volume of humidity produced can exceed the permitted pump volume under extreme conditions.

Therefore set up the alarm contact on the float switch so that dehumidification is stopped (e.g. by the cooling valve closing)

Note the following limits of use of the condensate pump for the max. permitted cooling conditions (CHW 6/10 °C with inlet air temperature 27 °C / 60% rel. humidity):

Ultra series 85: max. permitted delivery height with a 5 m hose length: 3 m

Ultra series 96: max. permitted delivery height with a 5 m hose length: 2 m

Higher-performance pumps are available on request if higher condensate volumes than the maximum permissible volumes need to be discharged.

Sound power level – Sound pressure level

The large-sized fans with low basic speeds permit extremely low noise levels. Nonetheless, take into account the permissible noise level in your design. Troublesome noises can occur specifically at higher fan speeds. Determine the design fan speed depending on the type of room.

We recommend checking the building approval regulations governing maximum permitted sound levels before commencing the design. Frequently reference is also made in this respect to other standards and regulations, e.g. DIN EN 15251, DIN EN 13779, Workplace Directive, VDI 2082 etc. The base sound level in a room plays a major role in the subjective perception of the source of the sound or the increased sound level. We would therefore recommend first measuring the base sound level to determine the permitted sound pressure level of the Ultra. If the sound pressure level of the unit lies below the room level, then the overall sound level will change only imperceptibly. However, if only very low sound levels are permitted, we would recommend designing the units so that the required output can be achieved at lower fan speeds.

Information on the A-rated total sound levels and sound pressure levels can be found in the technical data tables.

The sound power level needed to determine the differential sound level was calculated using the enveloping surface method as per DIN 45635 employing a comparison method.

The sound pressure level data based on the measurements of the sound power level applies to a low-reflection room with average sound absorption at a distance of 3 m and taken at an angle of 45° from the air outlet without a duct connection. The stated value can differ in practice as the actual sound pressure level in the room is seriously dependent on the acoustic properties of the space, on reflections, duct connections etc.

Coefficient of air resistance Z

Attachments		Z	
Description	Type	Model 5	Model 6
Recirculating air intake grille, square, 625 x 625 mm	60988	3.0 ¹⁾	3.0 ¹⁾
ISO Coarse 45% recirculating air filter attachment (used with an open ceiling)	6*050	4.0 ¹⁾	4.0 ¹⁾
Connecting frame, square	6*002	0.1 ¹⁾	0.1 ¹⁾
90° reducing bend, extended	6*104	1.1	1.1
90° air intake bend, with intake grille	60105	2.4 ¹⁾	3.4 ¹⁾
ISO Coarse 45% filter insert	60126	10.0 ¹⁾	14.0 ¹⁾
Rectangular air duct	6*030	0.1/m	0.1/m
Rectangular air duct section, 1250 mm long	6*130	0.1	0.1
Flexible connection, rectangular	6*034	0.1	0.1

¹⁾ Coefficients of air resistance based on air speed in a rectangular duct cross-section.

Heating and air volume correction factors for normal use

Ultra series 73-96												
	Ultra with recirculating air filter element				Ultra with connecting frame, reducing bend, flex. Connecting section and air intake bend with intake grille, without filter insert				Ultra with connecting frame, reducing bend, flex. Connecting section and air intake bend with intake grille, with filter insert			
Coefficients of air resistance	Total of Z = 4				Type series		Total of Z		Type series		Total of Z	
					85__		3.7		85__		13.7	
				96__		4.7		96__		18.7		
Ultra	Air volume		Heat output		Air volume		Heat output		Air volume		Heat output	
	f_{L3}		f_{Q3}		f_{L3}		f_{Q3}		f_{L3}		f_{Q3}	
	Fan speed stage ²⁾		Fan speed stage ²⁾		Fan speed stage ²⁾		Fan speed stage ²⁾		Fan speed stage ²⁾		Fan speed stage ²⁾	
Type	10 V	6 V	10 V	6 V	10 V	6 V	10 V	6 V	10 V	6 V	10 V	6 V
842058	0.84	0.81	0.89	0.86	On request							
	0.84	0.81	0.89	0.86								
	0.84	-	0.89	-								
843058	0.84	0.82	0.89	0.87								
	0.84	0.82	0.89	0.87								
	0.84	-	0.89	-								
852058	0.80	0.77	0.86	0.83	0.81	0.78	0.86	0.84	0.60	0.59	0.70	0.69
	0.80	0.77	0.86	0.83	0.81	0.78	0.86	0.84	0.60	0.59	0.70	0.69
	0.80	-	0.86	-	0.81	-	0.86	-	0.60	-	0.70	-
853058	0.80	0.78	0.86	0.84	0.81	0.79	0.86	0.85	0.61	0.60	0.71	0.70
	0.80	0.78	0.86	0.84	0.81	0.79	0.86	0.85	0.61	0.60	0.71	0.70
	0.80	-	0.86	-	0.81	-	0.86	-	0.61	-	0.71	-
854058	0.81	0.79	0.86	0.85	0.82	0.80	0.87	0.86	0.62	0.61	0.72	0.71
	0.81	0.79	0.86	0.85	0.82	0.80	0.87	0.86	0.62	0.61	0.72	0.71
	0.81	-	0.86	-	0.82	-	0.87	-	0.62	-	0.72	-
962058	0.73	0.71	0.80	0.79	0.72	0.70	0.80	0.78	0.49	0.49	0.61	0.61
962056	0.77	0.75	0.83	0.82	0.76	0.74	0.83	0.81	0.53	0.51	0.65	0.63
	0.73	0.71	0.80	0.79	0.72	0.70	0.80	0.78	0.49	0.49	0.61	0.61
	0.73	-	0.80	-	0.72	-	0.80	-	0.49	-	0.61	-
963058	0.74	0.72	0.81	0.80	0.73	0.71	0.80	0.79	0.50	0.49	0.62	0.61
963056	0.79	0.77	0.85	0.83	0.77	0.75	0.83	0.82	0.54	0.52	0.65	0.64
	0.74	0.72	0.81	0.80	0.73	0.71	0.80	0.79	0.50	0.49	0.62	0.61
	0.74	-	0.81	-	0.73	-	0.80	-	0.50	-	0.62	-
964058	0.75	0.73	0.82	0.80	0.74	0.72	0.81	0.80	0.51	0.50	0.63	0.62
964056	0.80	0.78	0.86	0.84	0.79	0.77	0.85	0.83	0.55	0.53	0.66	0.65
	0.75	0.73	0.82	0.80	0.74	0.72	0.81	0.80	0.51	0.50	0.63	0.62
	0.75	-	0.82	-	0.74	-	0.81	-	0.51	-	0.63	-

* Insert unit size

** Insert unit series

¹⁾ Coefficients of air resistance based on air speed in a rectangular duct cross-section

²⁾ Fan speed:

10 V = maximum speed

6 V = medium speed

Correction factors can also be used for Ultra type series 73_____

Hybrid ECO System

Air exchange separate from temperature control for comfort and efficiency

Public premises, workshops and retail stores are now not only heated and air conditioned by unit heaters, but can also be supplied with outside air. In this configuration, the extract air is discharged out of the building by means of natural overflow in accordance with the ErP Directive (EU) 1253/2014 without previously recovering the heat contained in it. This results in high energy costs.

Unlike simple ventilators that supply fresh air to a building, ventilation units with heat recovery offer the benefit of recovering heat from the extract air into the supply air in accordance with the ErP Directive (EU) 1253/2014.

If these units have an integral heating and cooling function, their many accessory components and long lengths of ductwork mean that they have to overcome high air-side resistance. What is more, the fans need a lot of energy. The surfaces of the air ducts are significantly larger and poorly insulated than pipes transporting water to generate energy. Too much energy is lost here as well.

Ultra units and the KaCompact ventilation unit, for example, have been designed to fulfil these two tasks, ventilation and temperature regulation, separately, at the same time recovering heat.

The KaCompact feeds filtered outside air into the building and removes exhaust air out of the building, like a conventional centralised ventilation unit. In addition, a rotary heat exchanger transfers heat from the exhaust air to the outside air/supply air and recovers a large proportion of the thermal energy that would otherwise be lost.

In doing so, it obviates the need for the equipment needed with large centralised ventilation units, like chillers, heaters and long lengths of ductwork. The temperature of the air (heating/cooling) is not adjusted in the ventilation unit, but rather outside in the Ultra unit.

One of the major benefits of this separation is the fact that the ventilation unit only needs to be operated with the required exchange of air. The ultra-efficient Ultra units are only operated at times when only heating or cooling is needed.

The energy-saving principle of the separation of functions is known as the Kampmann **"Hybrid ECO system"** and has been used by numerous customers for many years.

The air handling units are extremely important in this system and are designated as "fresh air units" if they meet the following criteria:

- ▶ heat recovery by means of a rotary heat exchanger or counterflow plate heat exchanger
- ▶ energy-saving continuously variable EC fans for precise adjustment of the air volume
- ▶ KaControl AUL control panel for control of air handling units and Ultra units

Possible air handling units for use in conjunction with Ultra units include:

- ▶ Airblock FG
- ▶ Airblock KG
- ▶ KaCompact

Combination example: two Ultra units with KaCompact ventilation unit

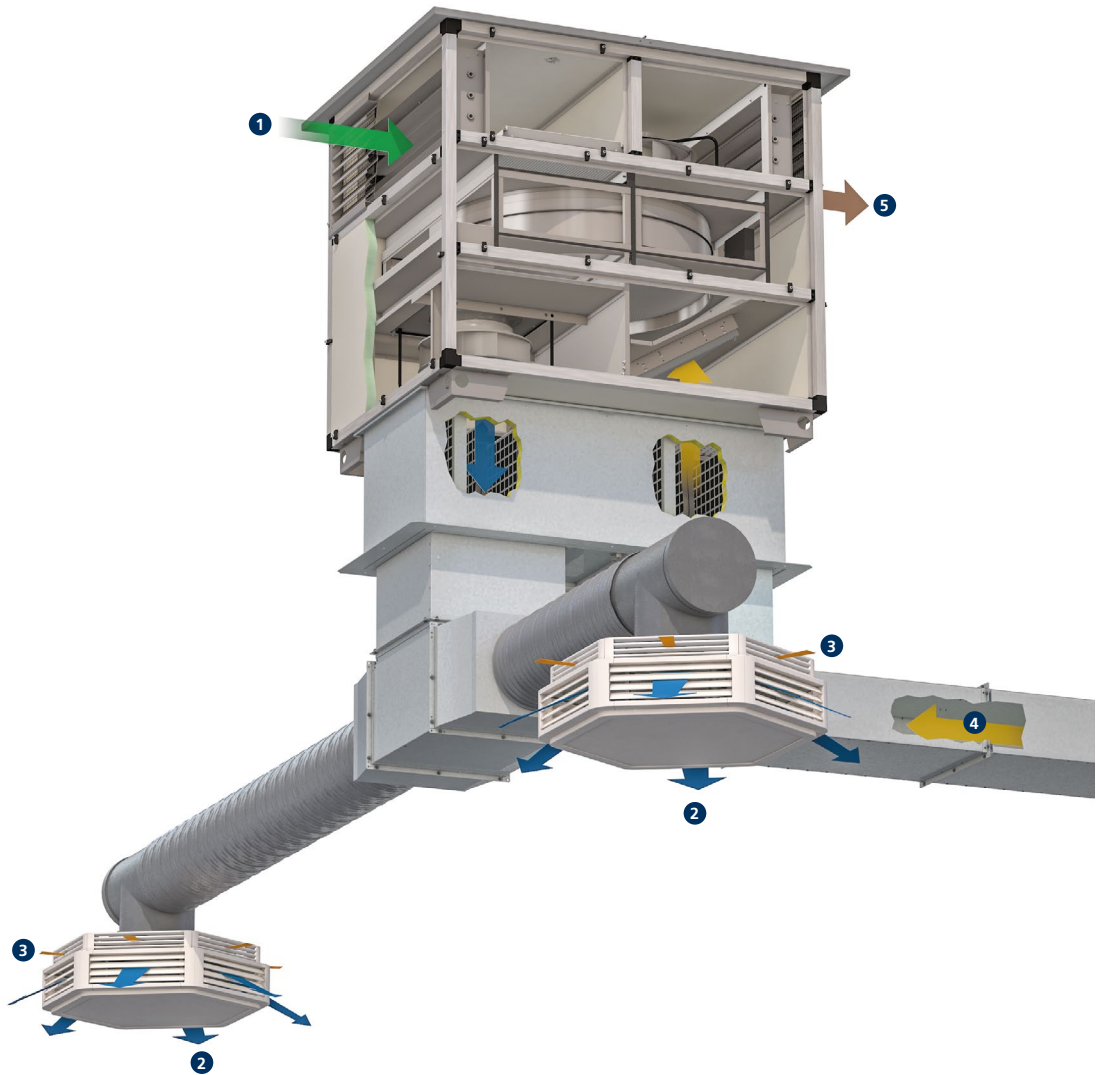

- ① Outside air
- ② Supply air
- ③ Secondary air
- ④ Exhaust air (exhaust air duct optional)
- ⑤ Extract air

04 ▶ Control



Control of Ultra – electromechanical model

Product features

The EC fans used can be continuously variably controlled by a 0-10 V DC signal.

The “intelligent” motor electronics detects any possible motor fault and automatically switches off the fan. This fault can be externally evaluated. The entire group or individual units are shut down in the event of a motor fault, depending on the control version. The speed can be limited to approx. 50% of the maximum speed by the potentiometer in the junction box. Actuation by Modbus-RTU instead of by a 0-10 V DC signal is possible depending on the type of unit heater.

Control units

Four different control units are available for operation and control.

Speed controller, type 30510

Continuously variable speed controller for use in conjunction with a thermostat for room temperature-dependent two-point control of heating or cooling units in closed rooms. The fan speed is set manually on the speed controller at between 0-100%. The thermostats activate the ventilation units at the pre-set speed depending on the temperature. It is possible to automatically switch between day and night mode using solutions with timer programs (type 30056; type 30076).

Room thermostat, type 30155

The EC recirculating air control unit type 30155 enables the operation and temperature control of heating/cooling recirculating air units in 2- or 4-pipe mode. The room temperature can be set on a rotary dial. The temperature is controlled by a fan and valve. In principle, the ventilation unit is switched on and off depending on the temperature and, at the same time, the valve is opened/closed. The fan can be operated manually at 3 stages or continuously variably in automatic mode. The control unit is also equipped with a frost protection function.

Clock thermostat, type 30256

The EC recirculating air control unit type 30256 enables the operation and temperature control of heating/cooling recirculating air units for 2- or 4-pipe mode. The room temperature can be set using the functional keys. The temperature is controlled by fan and valve. In principle, the ventilation unit is switched on and off depending on the temperature and, at the same time, the valve is opened/closed. The fan can be controlled at 10 stages, both in automatic mode as well as in manual mode. The control is also equipped with an automatic summer/winter changeover and a frost protection function. The built-in timer program also enables day or week programs to be set.

Electronic speed controller, type 30515

The continuously variable electronic compact controller is designed for the operation of up to 10 recirculating air units (2-pipe heating/cooling) with EC fans to heat and cool rooms. The controller has a temperature control, which works with a fan and shut-off valve. The temperature setpoint can be set for day and night mode. A digital timer, including day, night and week program, is also included. The room sensor supplied is installed separately.

A mean value can optionally be formed using 2 or 4 room sensors. Apart from continuously variable speed control, the fan speed can also be manually set. In addition, the control has a frost protection function, an external enable switch and a potential-free operating and collective fault alert, among other things. If required, the fan can also be used for pure air circulation without heating or cooling.

Cablling

The following points need to be taken into account with the cabling and wiring diagrams below:

- ▶ Comply with the details on type of cable and cabling taking into consideration VDE 0100.
- ▶ Without *: NYM-J. The requisite number of wires, including protective conductor, is stated on the cable. Cross-sections are not stated, as the cable length is involved in the calculation of the cross-section.
- ▶ With *: J-Y(ST)Y 0.8 mm, max. 100 m between the speed controller and the last unit heater; provide a shield on one side when longer than 20 m. Lay separately from power lines.
- ▶ With **: Sensor line 1.5 mm² e.g. J-Y(ST)Y, 4 x 2 x 0.8 mm, max. 100 m, lay separately from power lines.
- ▶ With ***: J-Y(ST)Y, 0.8 mm, max. 50 m, lay separately from power lines.
- ▶ With ****: J-Y(ST)Y, 0.8 mm, max. 100 m. Lay separately from power lines.
- ▶ If other types of cables are used, they must be at least equivalent.
- ▶ The terminals on the unit are suitable for a maximum wire cross-section of 2.5 mm², the mains plug for max. 4.0 mm².
- ▶ Any RCCBs used must be pulsating current-sensitive (type A). When the power supply to the unit is switched on, pulsating charging currents from the capacitors in the integral EMC filter can cause residual current protection devices to trip. We recommend the use of RCCBs with a tripping threshold of 300 mA.
- ▶ The electrical data listed in the following table needs to be considered when configuring the mains supply and fuses on site.

Maximum number of connectible Ultra with EC fan per speed control unit

Speed control unit			
Type 30510	Type 30155	Type 30256	Type 30515
[Number]	[Number]	[Number]	[Number]
10	2	2	10

Electrical data for Ultra, electromechanical model

Unit heater type	Nominal voltage [V]	Mains frequency [Hz]	Active power [kW]	Nominal current [A]	Leakage current [mA]	Max. fuse [A]	IP protection rating	Protection class
73xx58	230	50/60	0.14	1.27	< 3.5	B10	54	I
84xx58	230	50/60	0.14	1.27	< 3.5	B10	54	I
85xx58	230	50/60	0.17	1.51	< 3.5	B10	54	I
96xx58	230	50/60	0.46	2.13	< 3.5	C16	54	I
96xx56	230	50/60	0.46	2.13	< 3.5	C16	54	I

xx Heat exchanger model

Cabling of Ultra (00), actuation by speed controller type 30510 with industrial thermostat type 30058/30059**

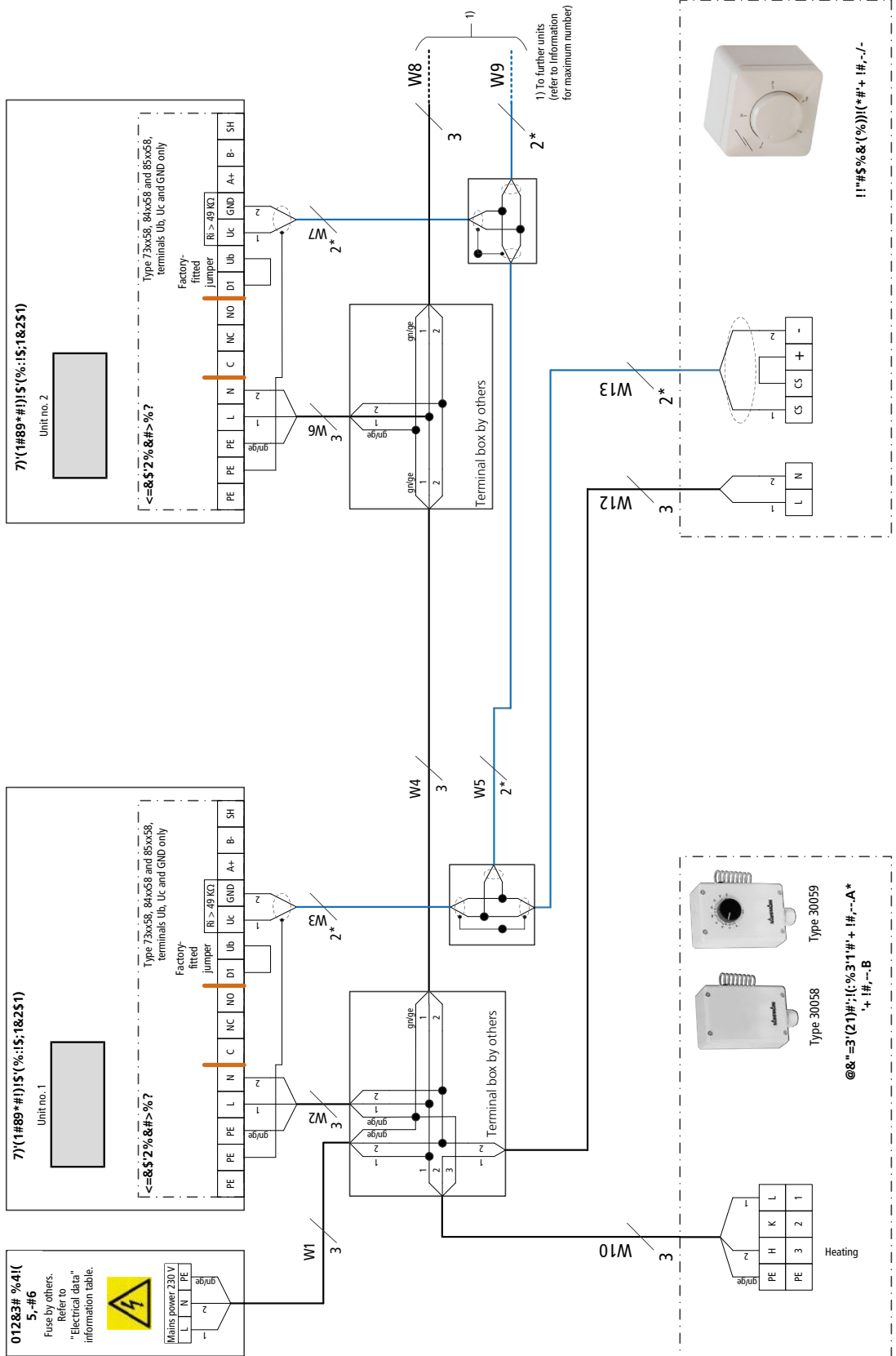

Cabling of Ultra (**00), actuation by speed controller type 30510 with room thermostat type 30055

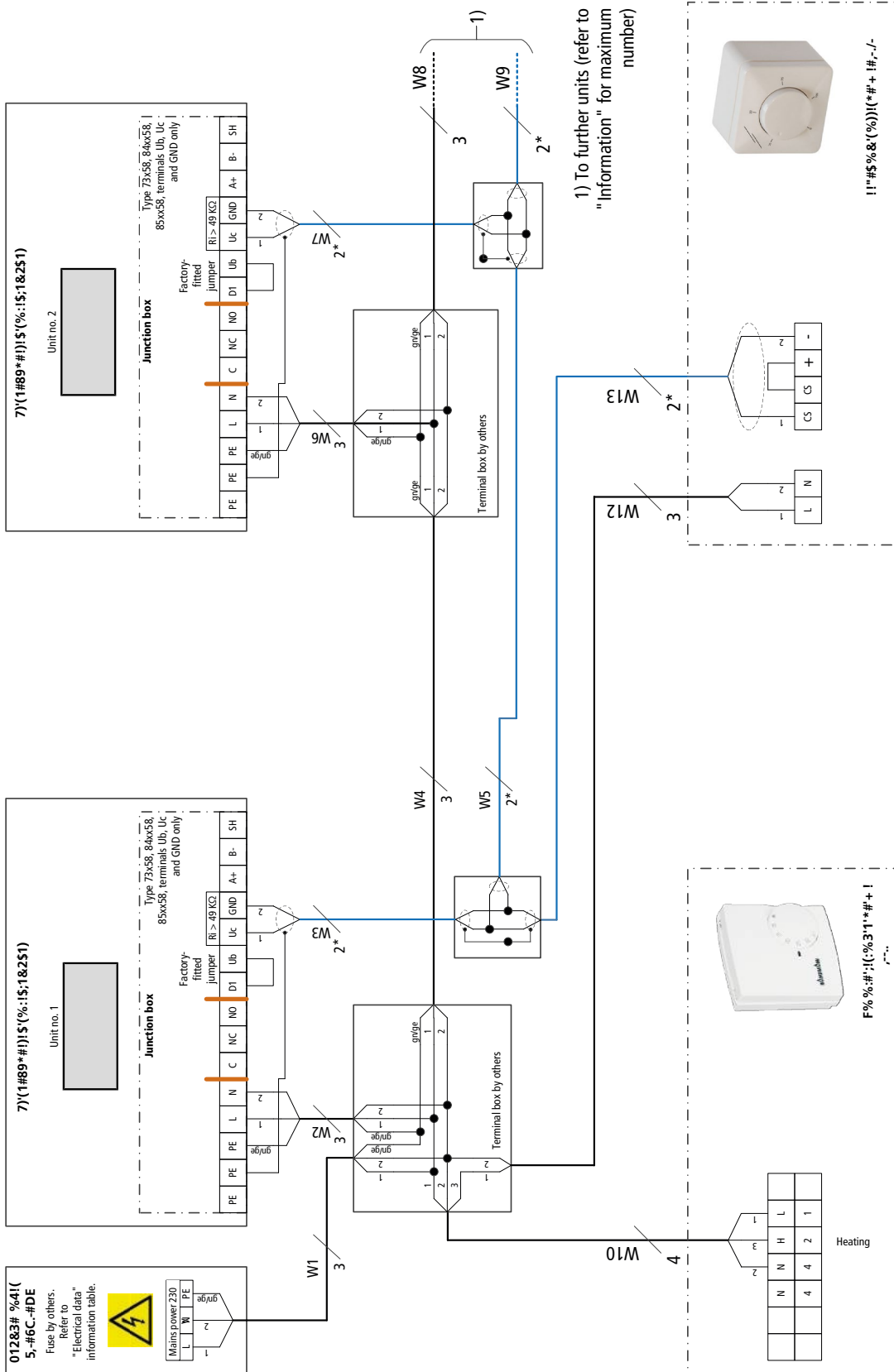

Cabling of Ultra(**00), actuation by speed controller type 30510 with clock thermostat type 30056

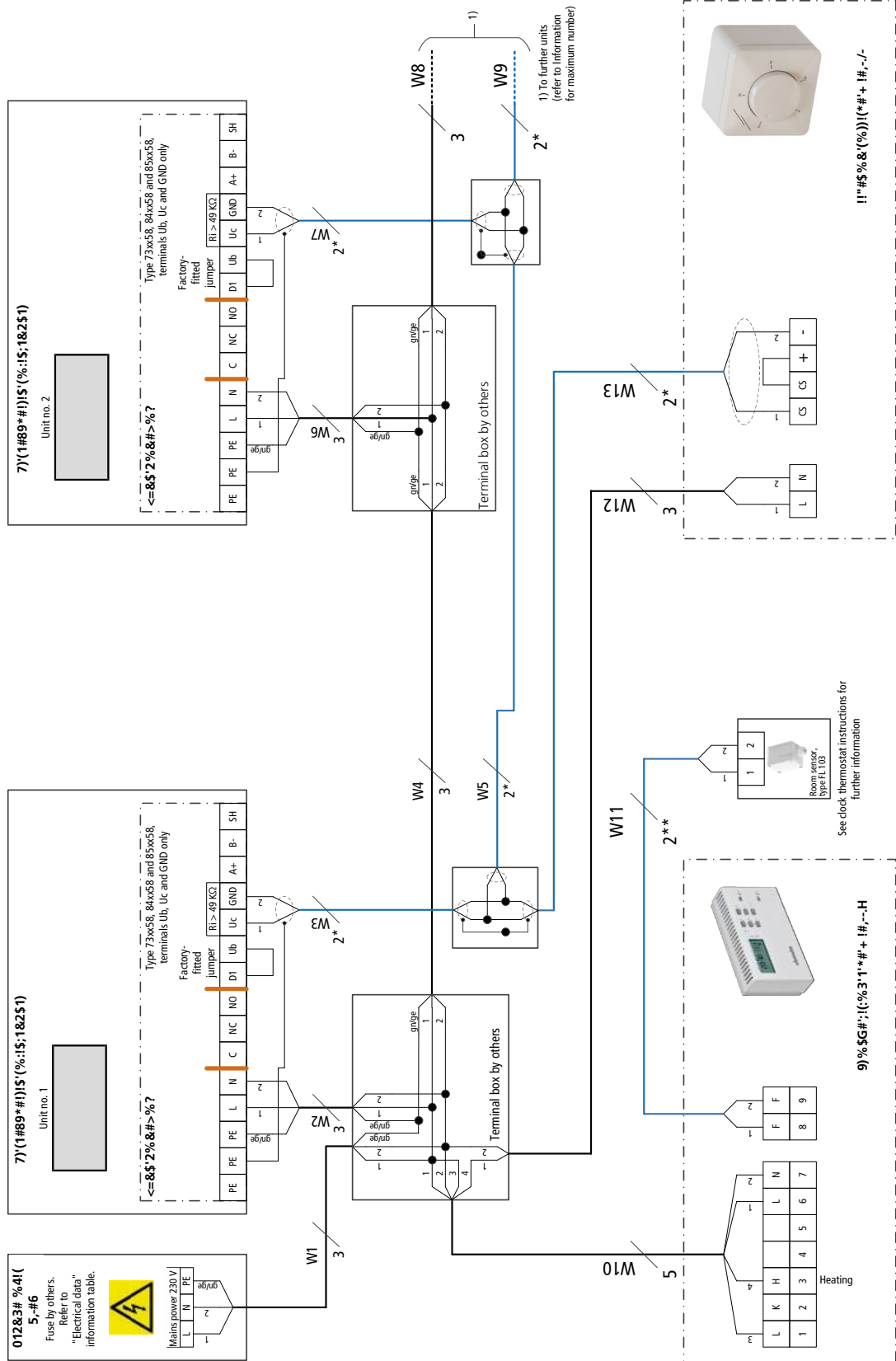

Cabling of Ultra (**00), actuation by climate controller type 30155, 2-pipe valve actuator 230 V AC, Open/Close

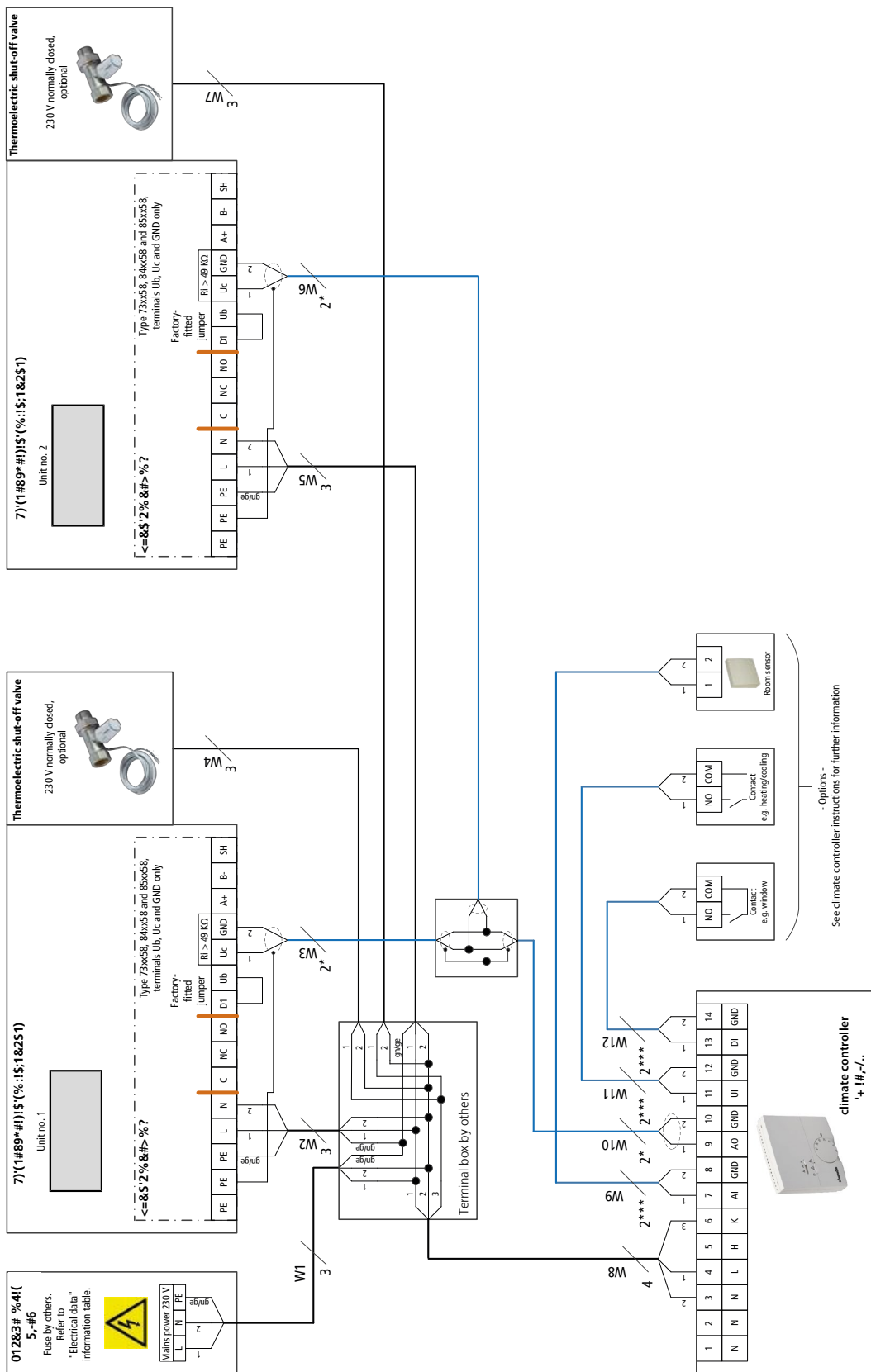

- Options -
See climate controller instructions for further information

Cabling of Ultra (00), actuation by climate controller type 30256, 2-pipe valve actuator 230 V AC, Open/Close**

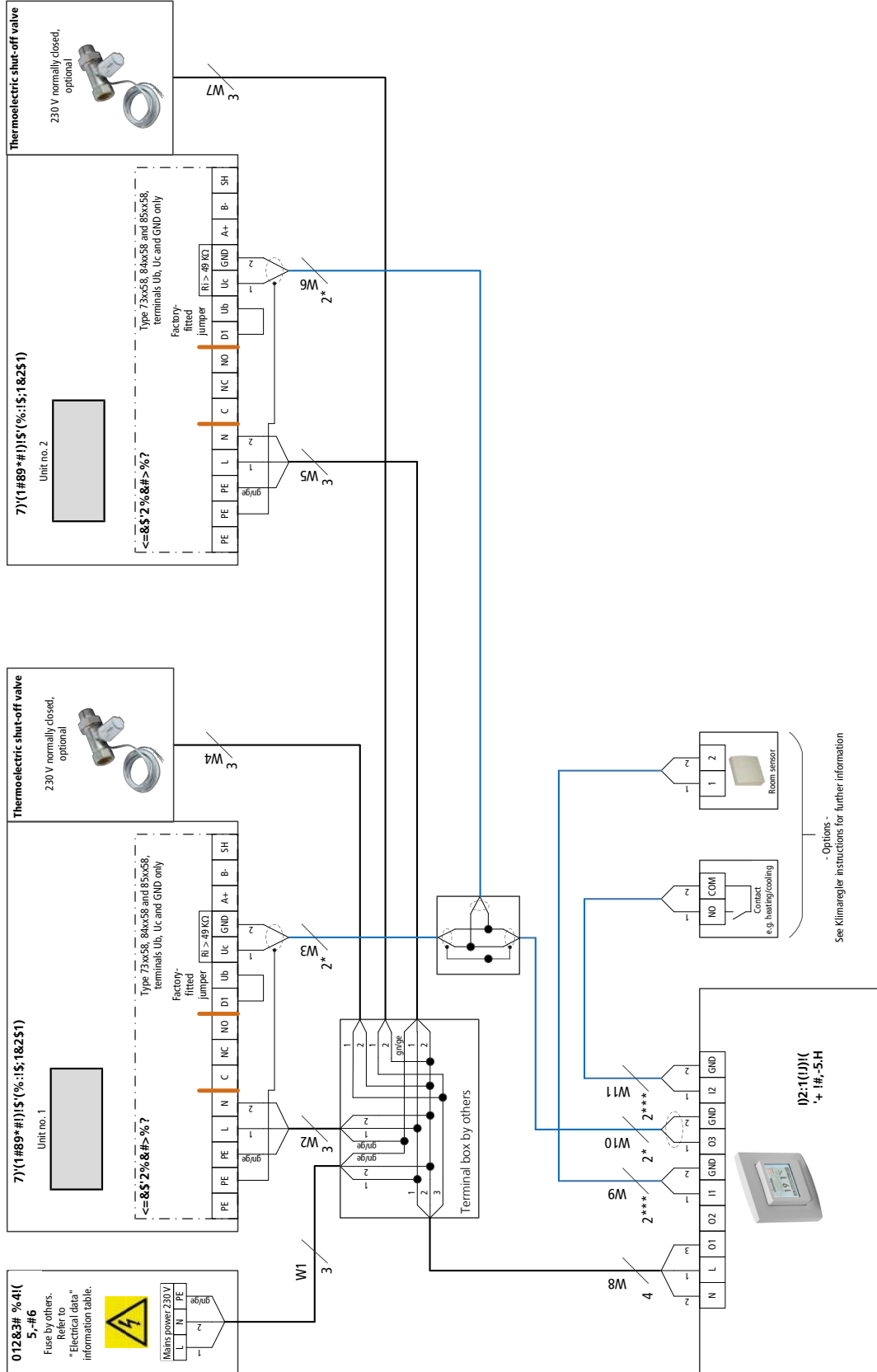

Cabling of Ultra (*00), actuation by speed controller type 30515

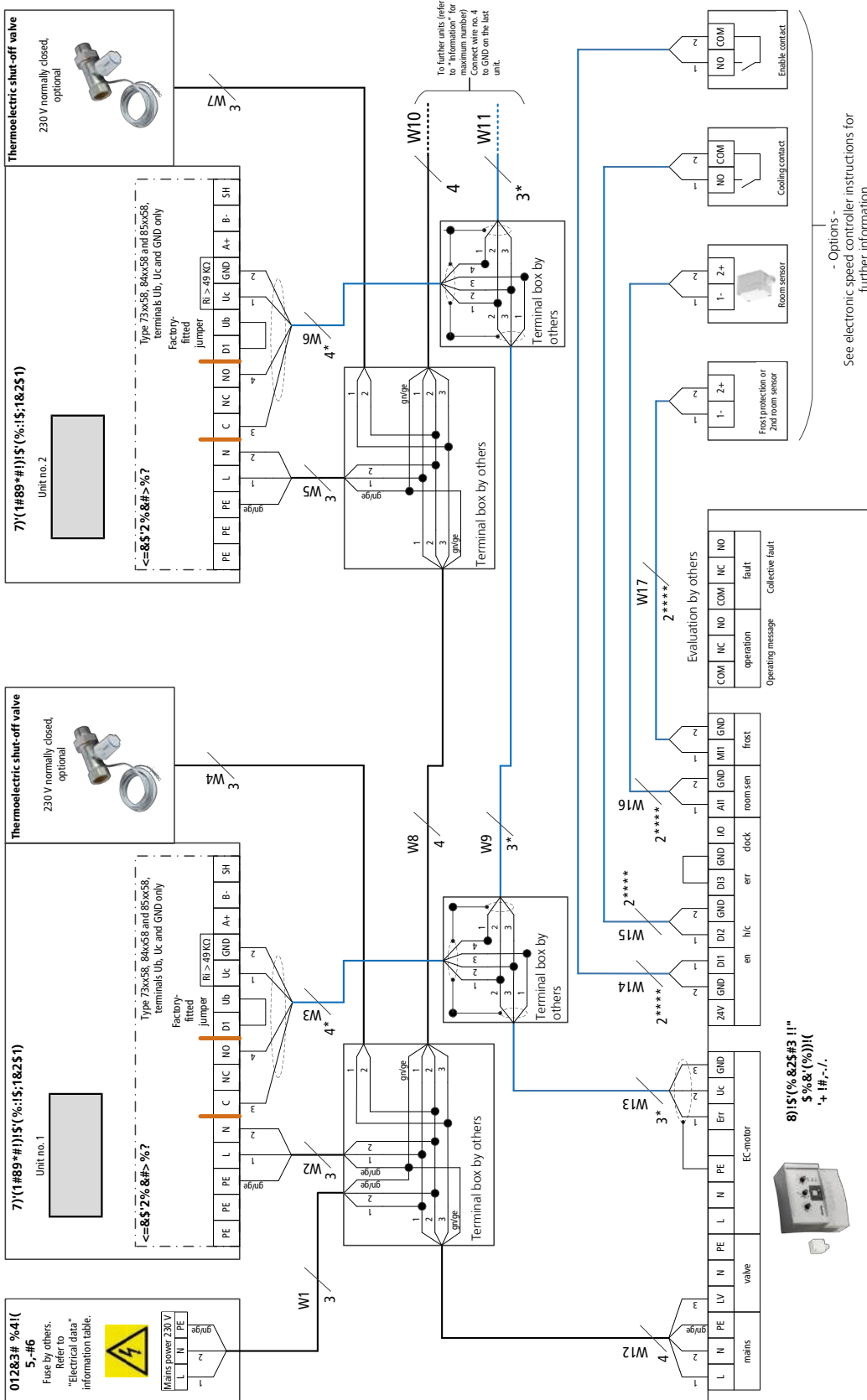

Cabling of Ultra (**00), actuation by DDC/BMS, 2-pipe valve actuator 230 V AC, Open/Close

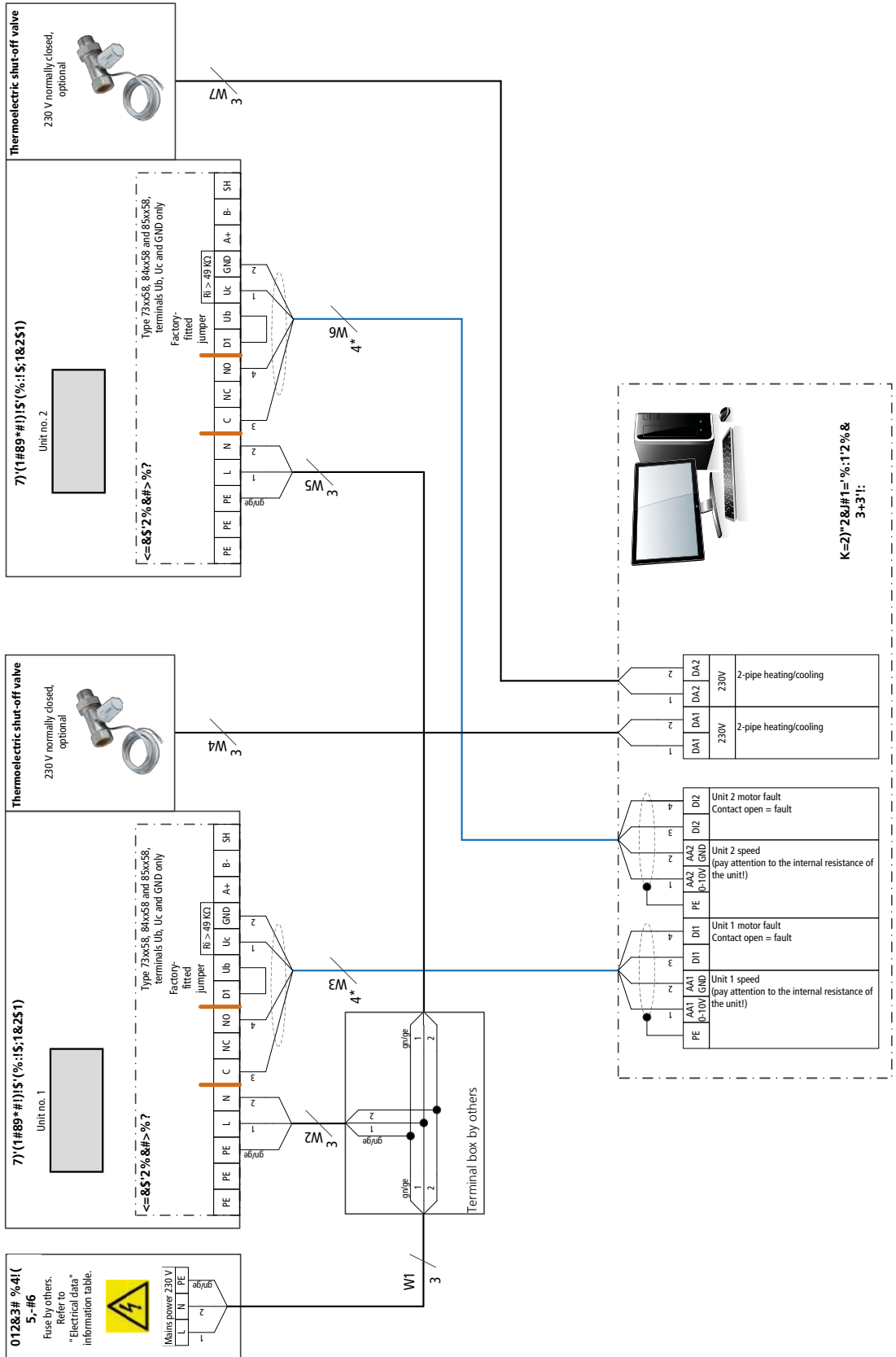

Control of Ultra – KaControl model

The all-inclusive solution!

Product features

Units configured for operation with KaControl are fully wired and fitted with all electrical parts ready for connection (with the exception of optional accessories). The built-in, high-performance, parametrisable KaControl microprocessor control provides all the functions the Ultra needs.

The “face” of the KaControl is the KaController operating unit. A group of up to two units can be formed using a KaController unit without the need for additional addressing.

Optional plug-in interface cards offer the option of connecting to higher-level control systems.

Fans

The speed of the EC fans used in the units is controlled by a 0-10 V DC signal from the KaControl. The “intelligent” motor electronics detects any possible motor fault and automatically switches off the fan. A motor fault on the unit to which the KaController is connected is displayed on the KaController.

Control unit

Various versions of the KaController operating unit are available for operation and control.

KaController

The KaController offers maximum operating convenience with a large display, one-touch operation and optionally also with side operating keys for quick access. Based on the principle of “as little as possible, as much as required”, even untrained users can intuitively get to grips with the control options.

The displays are language-independent using pictograms. The basic functions are inputted in a user-friendly way using the KaController.



Type 196003214002



Type 196003210001



Type 196003210002



Type 196003210006

Product features of the KaController

- ▶ plastic housing, colour similar to RAL 9010 (type 196003210001 and 196003210002) or black (type 196003210006) for surface-mounting on a flush back box or surface-mounting with a surface-mounted frame (accessory)
- ▶ high-quality design of room control units, large LCD multifunctional display with energy-saving, automatically switching LED backlight
- ▶ push-turn navigator dial with endless turn/lock function
- ▶ side function keys for quick access (only with type 196003210002)
- ▶ integral temperature sensor
 - ▶ **Important!** the model in an industrial housing always needs a separate room temperature sensor
- ▶ individually adjustable basic display
- ▶ display of fault messages
- ▶ built-in weekly switching program
- ▶ password-protected parameter level

KaControl

The parametrisable KaControl microprocessor control offers a wealth of functions. The following default functions are factory-set for the Ultra product:

- ▶ 2-pipe applications, thermal valve actuators 24 V AC Open/Close, normally closed
- ▶ room temperature control with 2-point valve control and demand-led fan control in automatic mode or optionally fixed stage selection
- ▶ optional use of the internal or external room temperature sensor (accessory)
- ▶ in the event of an alarm being triggered on a device to which the KaController room control unit is connected, e.g. a motor fault is detected by the KaControl and indicated on the KaController control unit
- ▶ heating/cooling changeover control input with 2-pipe systems
- ▶ control input can either be set to Comfort/ECO or ON/OFF changeover
- ▶ switching output 24 V DC/max. 0.5 A parametrisable to unit alarm, heating or cooling demand (only with 2-pipe applications)
- ▶ sequential valve actuation (Open/Close) and fan speed via a data point
- ▶ 0-10 V DC only with actuation without KaController
- ▶ one slot for optional interface cards for connection to a higher-level building automation system – optionally Modbus, KNX, BACnet (accessory)
- ▶ password-protected parameter level
- ▶ parallel operation of a maximum of 2 units is possible, extendible to a maximum of 30 units using an additional CANbus card type 3260301 (accessory) per unit

Any additional functions required can be parametrised and correspondingly coordinated.

Cabling

The following points need to be taken into account with the cabling and wiring diagrams below:

- ▶ Comply with the details on the type of cable and cabling, taking into consideration DE 0100.
- ▶ Without *: NYM-J. The requisite number of wires, including protective conductor, is stated on the cable. Cross-sections are not stated, as the cable length is involved in the calculation of the cross-section.
- ▶ With *: J-Y(ST)Y 0.8 mm. Lay separately from power lines.
- ▶ With **: UNITRONIC BUS LD 0.22 mm². Lay separately from power lines.
- ▶ If other types of cables are used, they must be at least equivalent.
- ▶ Length of BUS cable from the KaController to unit 1: max. 30 m.
- ▶ Maximum number of parallel units: 2 units. Maximum 30 units with a CANbus card type 3260301 (see Accessories) required for each unit and a terminal resistor on the first and last unit.
- ▶ Length of BUS cable from unit 1 to unit 2 max. 30 m. Max. 500 m with a CANbus card type 3260301 (see accessories) needed for each unit.
- ▶ Length of cable for room sensor and switching contact maximum 30 m, maximum 100 m from 1 mm²
- ▶ The terminals on the unit for the mains power supply are suitable for a maximum wire cross-section of 2.5 mm².
- ▶ Any RCCBs used must be pulsating current-sensitive (type A). When the power supply to the unit is switched on, pulsating charging currents from the capacitors in the integral EMC filter can cause residual current protection devices to trip. We recommend the use of RCCBs with a tripping threshold of 300 mA.
- ▶ The electrical data listed in the following table needs to be considered when configuring the on-site mains power supply and fuses.

Electrical data for Ultra, KaControl model

Unit heater type	Nominal voltage [V]	Mains frequency [Hz]	Active power [kW]	Nominal current [A]	Leakage current [mA]	Max. fuse [A]	IP protection rating	Protection class
84xx58C1	230	50/60	0.14	1.27	< 3.5	B10	54	I
85xx58C1	230	50/60	0.17	1.51	< 3.5	B10	54	I
96xx58C1	230	50/60	0.46	2.13	< 3.5	C16	54	I
96xx56C1	230	50/60	0.46	2.13	< 3.5	C16	54	I

Electrical data without KaControl and valve actuator
xx Heat exchanger model

Cabling of Ultra (*C1), actuation by KaController type 321000x, 2-pipe, 24 V DC valve, Open/Close

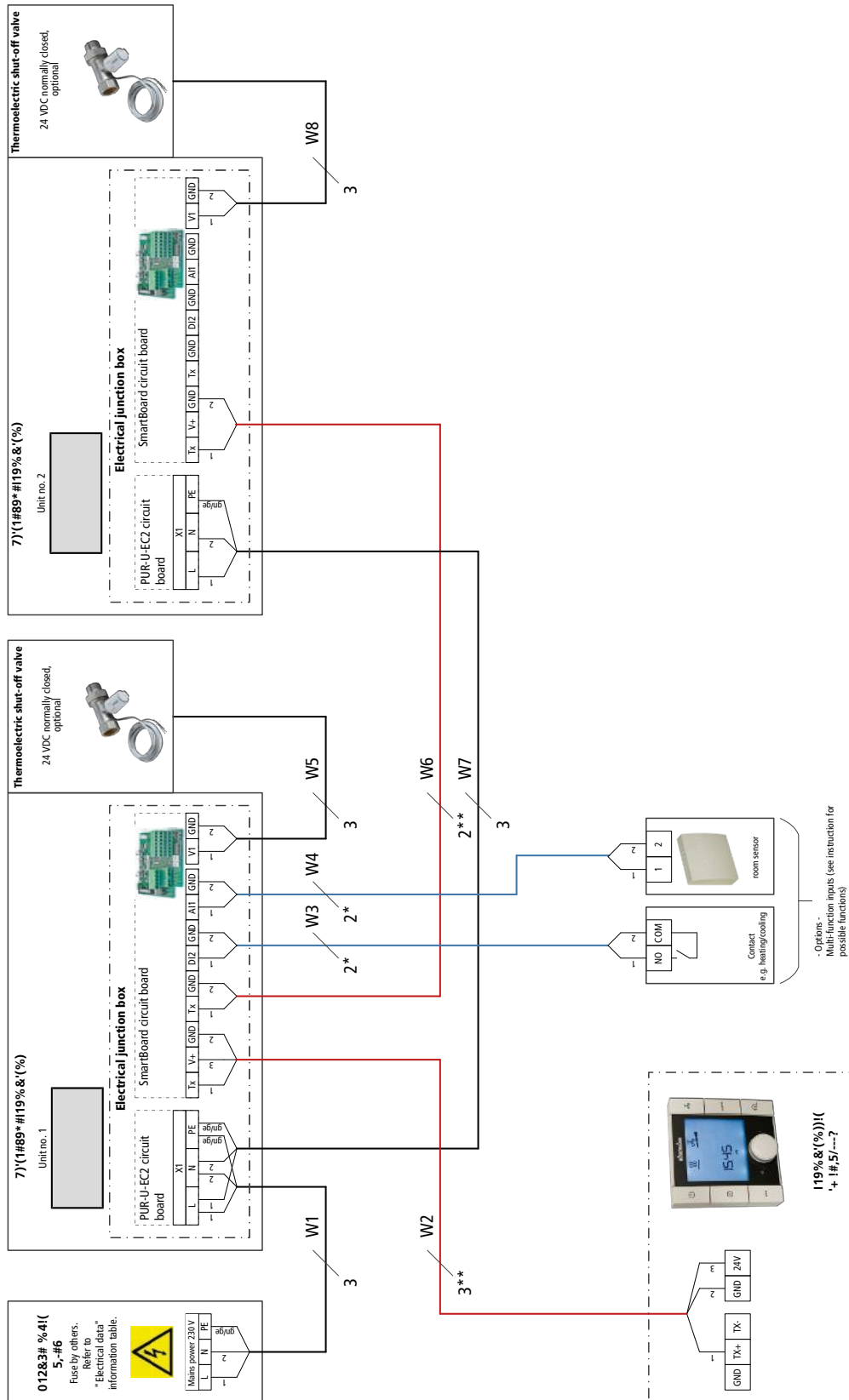

Cabling of Ultra (*C1), actuation by KaController type 321000x, 2-pipe, 24 V DC valve, Open/Close, with CANbus card

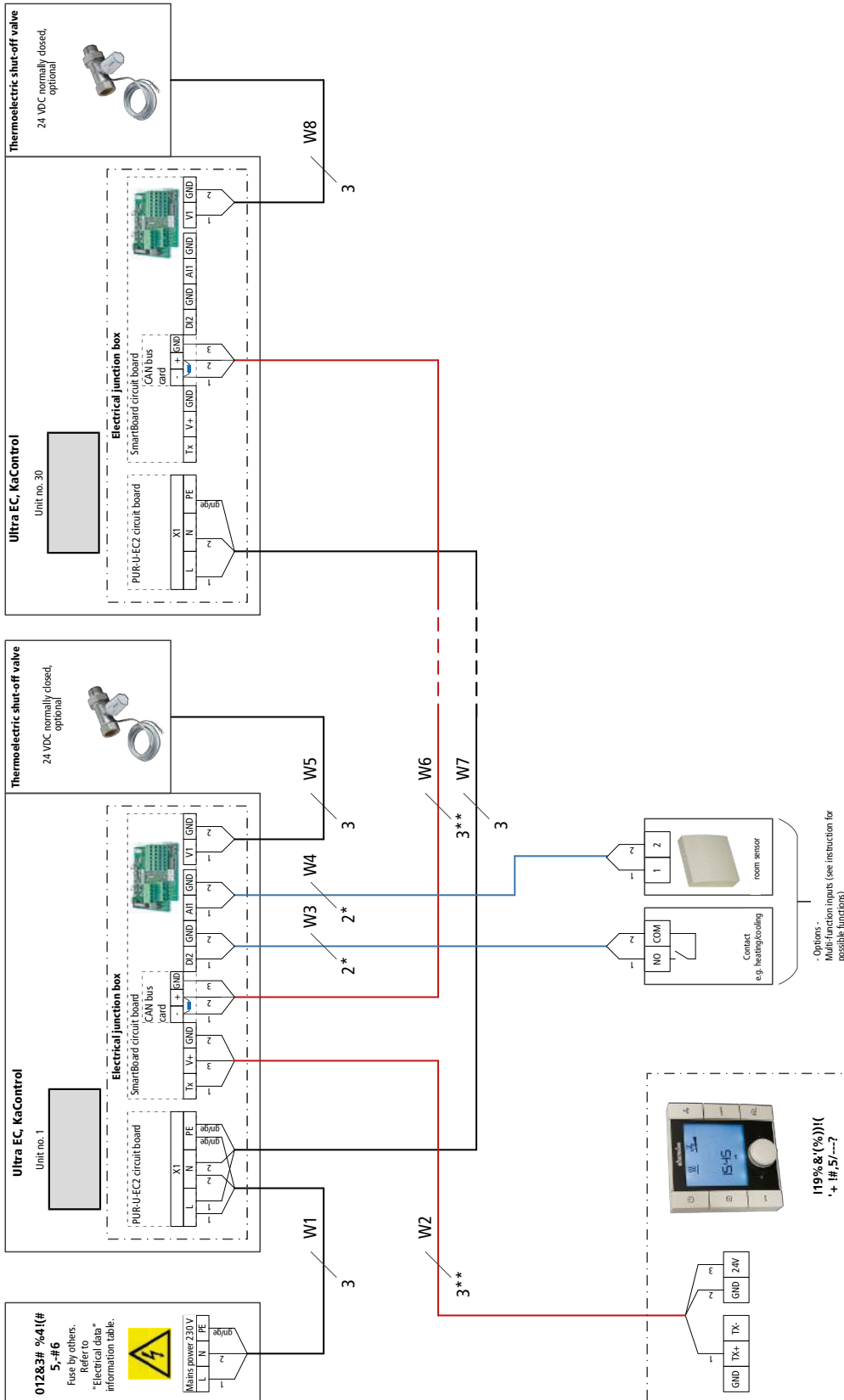

Cabling of Ultra (*C1), actuation by 0-10 V DC signal by others

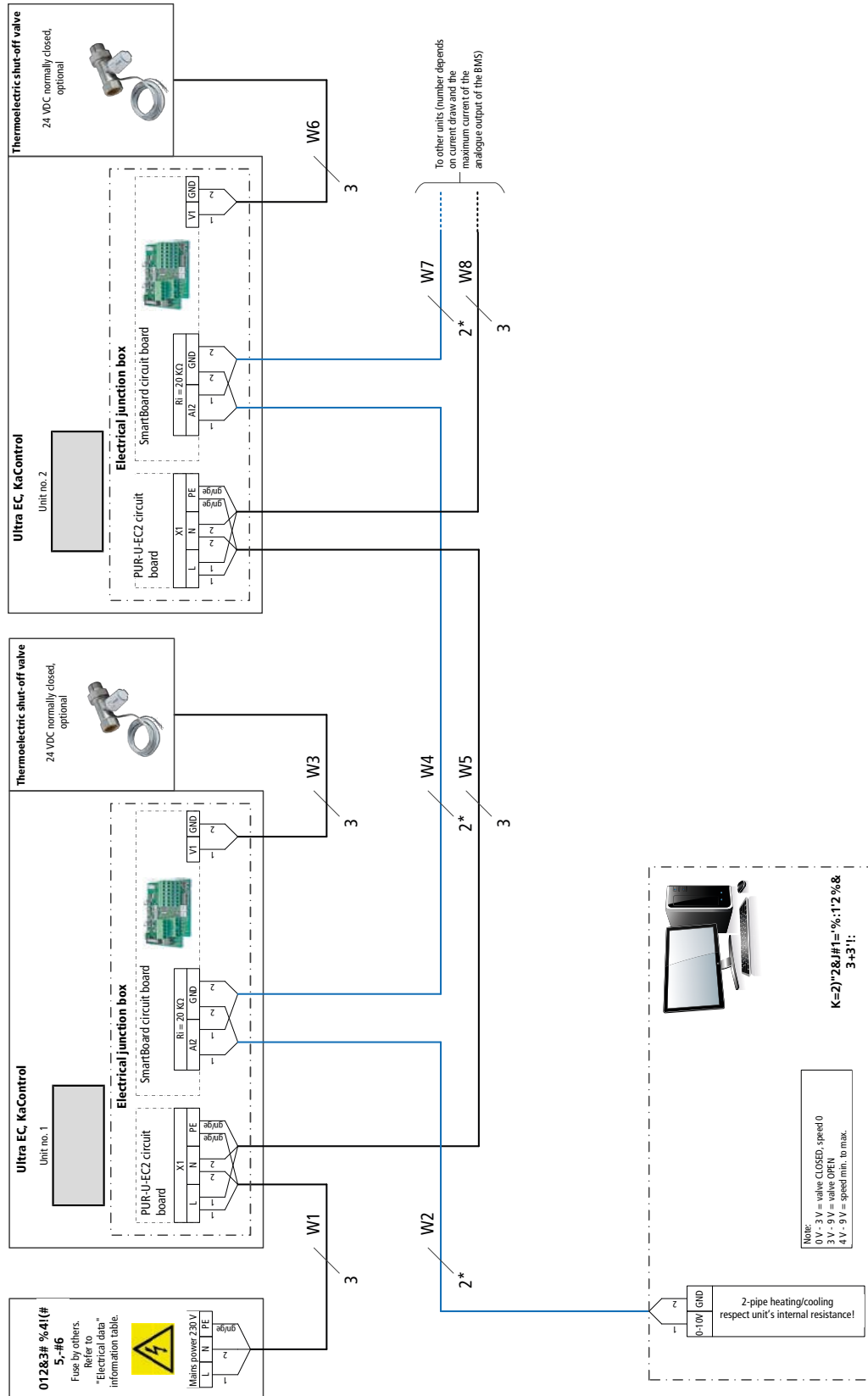

KaControl – integration into intelligent building networks (IoT)

KaControl offers a wealth of options for integration into established communication networks. Various building automation strategies can be configured using different options.

Individual switching of units

Units with KaControl configuration can be directly integrated into on-site networks using optional communication interfaces. Control and monitoring is provided by fixed data points. Operation is provided by the KaController or by the control units belonging to the network.

Switching of groups

Up to six units with KaControl configuration can be operated in a single group. Groups of units can be directly integrated into on-site networks using optional communication interfaces. Control and monitoring is provided by fixed data points. Operation of a group is provided by the KaController or by control units belonging to the network.

Communication interfaces

The following communication interfaces can be supplied separately or factory-fitted.

- ▶ Modbus RTU
- ▶ KNX
- ▶ BACnet IP

Note:

More information on integration into intelligent building networks and the associated communication interfaces is available on request!

KaControl – system controller

The optional Modbus interface allows units with KaControl configuration to be networked into systems individually or into groups with factory-programmed higher-level Kampmann system controllers.

KaControl SEL control panel



- ▶ up to 60 secondary air units or door air curtains split into up to 24 groups (zones), identical units required within a group, up to 6 units per group
- ▶ optional: KaController is possible for each group
- ▶ central heating (winter)/cooling (summer) switch-over of secondary air units or heating (winter)/ventilation (summer)
- ▶ 5 timer programs can be assigned to groups
- ▶ optional: BACnet IP gateway for connection to higher-level control systems for the units/zones

KaControl AUL control panel



- ▶ one Kampmann ventilation system
- ▶ up to 60 secondary air units or door air curtains divided into up to 10 groups (zones), identical units required within one group, up to 6 units per group
- ▶ optional: KaController unit for each group
- ▶ central heating (winter)/cooling (summer) switch-over of secondary air units or heating (winter)/ventilation (summer)
- ▶ 5 timer programs can be assigned to groups
- ▶ optional: BACnet IP gateway for connection to higher-level control systems for the units/zones

KaControl visualisation



- ▶ up to 100/300 units
- ▶ optional: KaController unit for each group
- ▶ central heating (winter)/cooling (summer) changeover of secondary air units or heating (winter)/ventilation (summer) of door air curtains
- ▶ central timer programs
- ▶ visualisation of Kampmann secondary air units, door air curtains and ventilation systems

Note:

More information on KaControl system controllers can be provided on request!

05 ▶ Ordering information

Ultra

Fan version	Model size	Length	Width	Height	Heat exchanger performance	Control option	Article no.
		[mm]	[mm]	[mm]			

Heat exchanger model copper/aluminium









EC fan, 230 V, high speed	73	750	840	330	2-row, heat exchanger code no. 20	electromechanical	154000732058
						electromechanical with repair switch	154000732058OR
					3-row, heat exchanger code no. 30	electromechanical	154000733058
						electromechanical with repair switch	154000733058OR
EC fan, 230 V, high speed	84	900	1004	330	2-row, heat exchanger code no. 20	electromechanical	154000842058
						electromechanical with frost protection thermostat	154000842058F0
						electromechanical with repair switch	154000842058OR
						KaControl	154000842058C1
					3-row, heat exchanger code no. 30	frost protection thermostat and repair switch	154000842058FR
						electromechanical	154000843058
						electromechanical with frost protection thermostat	154000843058F0
						electromechanical with repair switch	154000843058OR
					3-row, heat exchanger code no. 31	KaControl	154000843058C1
						frost protection thermostat and repair switch	154000843058FR
						electromechanical	154000843158
						electromechanical with frost protection thermostat	154000843158F0
EC fan, 230 V, high speed	85	900	1004	330	2-row, heat exchanger code no. 20	electromechanical with repair switch	154000843158OR
						KaControl	154000843158C1
						frost protection thermostat and repair switch	154000843158FR
						electromechanical	154000852058
					3-row, heat exchanger code no. 30	electromechanical with frost protection thermostat	154000852058F0
						electromechanical with repair switch	154000852058OR
						KaControl	154000852058C1
						frost protection thermostat and repair switch	154000852058FR
					3-row, heat exchanger code no. 31	electromechanical	154000853058
						electromechanical with frost protection thermostat	154000853058F0
						electromechanical with repair switch	154000853058OR
						KaControl	154000853058C1
4-row, heat exchanger code no. 40	frost protection thermostat and repair switch	154000853058FR					
	electromechanical	154000854058					
	electromechanical with frost protection thermostat	154000854058F0					
	electromechanical with repair switch	154000854058OR					
3-row, heat exchanger code no. 31	KaControl	154000854058C1					
	frost protection thermostat and repair switch	154000854058FR					
	electromechanical	154000853158					
	electromechanical with frost protection thermostat	154000853158F0					
4-row, heat exchanger code no. 41	electromechanical with repair switch	154000853158OR					
	KaControl	154000853158C1					
	frost protection thermostat and repair switch	154000853158FR					
	electromechanical	154000854158					
	electromechanical with frost protection thermostat	154000854158F0					
	electromechanical with repair switch	154000854158OR					
	KaControl	154000854158C1					
	frost protection thermostat and repair switch	154000854158FR					

▶ CONTINUED ▶

Ultra

Fan version	Model size	Length [mm]	Width [mm]	Height [mm]	Heat exchanger performance	Control option	Article no.					
EC fan, 230 V, high speed	96	1050	1177	330	2-row, heat exchanger code no. 20	electromechanical	154000962058					
						electromechanical with frost protection thermostat	154000962058F0					
						electromechanical with repair switch	154000962058OR					
						KaControl	154000962058C1					
					3-row, heat exchanger code no. 30	frost protection thermostat and repair switch	154000962058FR					
						electromechanical	154000963058					
						electromechanical with frost protection thermostat	154000963058F0					
						electromechanical with repair switch	154000963058OR					
					4-row, heat exchanger code no. 40	KaControl	154000963058C1					
						frost protection thermostat and repair switch	154000963058FR					
						electromechanical	154000964058					
						electromechanical with frost protection thermostat	154000964058F0					
					3-row, heat exchanger code no. 31	electromechanical with repair switch	154000964058OR					
						KaControl	154000964058C1					
						frost protection thermostat and repair switch	154000964058FR					
						electromechanical	154000963158					
					4-row, heat exchanger code no. 41	electromechanical with frost protection thermostat	154000963158F0					
						electromechanical with repair switch	154000963158OR					
						KaControl	154000963158C1					
						frost protection thermostat and repair switch	154000963158FR					
					EC fan, 230 V, high speed	96	1050	1177	330	2-row, heat exchanger code no. 20	electromechanical	154000964158
											electromechanical with frost protection thermostat	154000964158F0
											electromechanical with repair switch	154000964158OR
											KaControl	154000964158C1
3-row, heat exchanger code no. 30	frost protection thermostat and repair switch	154000964158FR										
	electromechanical	154000963156										
	electromechanical with frost protection thermostat	154000963156F0										
	electromechanical with repair switch	154000963156OR										
4-row, heat exchanger code no. 40	KaControl	154000963156C1										
	frost protection thermostat and repair switch	154000963156FR										
	electromechanical	154000964156										
	electromechanical with frost protection thermostat	154000964156F0										
3-row, heat exchanger code no. 31	electromechanical with repair switch	154000964156OR										
	KaControl	154000964156C1										
	frost protection thermostat and repair switch	154000964156FR										
	electromechanical	154000964156										
4-row, heat exchanger code no. 41	electromechanical with frost protection thermostat	154000964156F0										
	electromechanical with repair switch	154000964156OR										
	KaControl	154000964156C1										
	frost protection thermostat and repair switch	154000964156FR										

Accessories



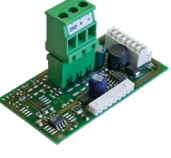

Article	Article	Properties	Dimensions [mm]	Suitable for	Article no.
Control accessories KaControl					
	KaController	with one-button operation, 24 V wall-mounted room control unit, with integral room temperature sensor, Colour similar to RAL 9010 pure white	86 x 52 x 86	all units with control option KaControl -C1	196003210001
	KaController	with one-button operation, 24 V wall-mounted room control unit, with integral room temperature sensor, Colour similar to RAL 9017 traffic black	86 x 52 x 86	all units with control option KaControl -C1	196003210006
	KaController	with side operating keys, 24 V wall-mounted room control unit, with integral room temperature sensor, Colour similar to RAL 9010 pure white	86 x 52 x 86	all units with control option KaControl -C1, ProtecTor Door Air Curtains	196003210002
	Industry KaController	with side operating keys, industrial housing with hinged transparent cover, lockable, Surface-mounted, Protection class IP 65	200 x 110 x 195	all units with control option KaControl -C1, ProtecTor Door Air Curtains	196003214002
	Room temperature sensor	Wall-mounted, Surface-mounted, Protection class IP 30, Colour RAL 9010 pure white Is the KaController installation site suitable for a temperature measurement? - If it is not suitable, e.g. behind a curtain, then a KaControl room temperature sensor should be chosen for each group!	85 x 25 x 85	all units with KaControl -C1 and climate controller art. no. 19600014894*	196003250110
	Outside temperature sensor/industrial temperature sensor	Surface-mounted, Protection class IP 65, Colour similar to RAL 9010 pure white	63 x 68 x 57	all units with control option KaControl -C1, ProtecTor Door Air Curtains	196003250112
	Clip-on pipe sensor	to detect the medium temperature, heating/cooling changeover function only in conjunction with 3-way valve! Is there a risk of frost, e.g. due to the ingress of cold air – if so, then a KaControl clip-on pipe sensor should be chosen for each unit!	5 x 6 x 3000	all units with control option KaControl -C1	196003250115
	Serial KNX card	for integration into a KNX/EIB network, interface PCOS00KXN0, Protection class IP 0	35 x 20 x 80	all units with control option KaControl -C1	196003260702

CONTINUED ▶

Accessories

Article	Article	Properties	Dimensions	Suitable for	Article no.
			[mm]		
	Serial CANbus card	to increase the number of units in a single-circuit system from 7 to a maximum of 30 units, one required per unit, Extension of the cable length from the first to the last unit from 30 m to 500 m	35 x 30 x 60	all units with control option KaControl -C1	196003260301
	Serial Modbus card	Required for each device for connection to KaControl panels or on-site Modbus networks.	31 x 12 x 61	all units with control option KaControl -C1	196003260101

Control accessories electromechanical 230 V





	Room thermostat	Heating/Cooling, 2- and 4-pipe, 3-stage. Only in conjunction with valves/valve kits with actuator, 230 V AC, Open/Closed, with OFF/Manual/Automatic fan switch-over, Surface-mounted	110 x 111 x 26	EC units electromechanical, 5 Katherm HK Trench Technology, 2 TOP or Ultra Unit Heaters, 2 Venkon, KaCool D AF or KaCool W Fan Coils	196000030155
	Clock thermostat	Heating/Cooling, 2- and 4-pipe, continuously variable, with LCD operating menu and integrated timer program, 230 V AC, flush-mounted	85 x 46 x 81	EC units electromechanical, 2 TOP or Ultra Unit Heaters, 5 Venkon Fan Coils, 2 KaCool D AF or KaCool W Fan Coils	196000030256
	Speed controller	continuously variable fan operation, 0-100% presettable, 230 V AC, 10 V, 0-100%, On/Off via room thermostat, surface-mounted protection class IP 54, flush-mounted protection class IP 44	82 x 82 x 68	EC units electromechanical, 2 ProtecTor Door Air Curtains, 5 UniLine or Tandem Door Air Curtains, 10 TOP or Ultra Unit Heaters, 10 Venkon Fan Coils, 2 KaCool D AF or KaCool W Fan Coils	196000030510
	Electronic speed controller	with integral digital timer, 230 V AC, with day, night, week programme, continuously variable fan operation 0 to 100 %, manual or automatic, 0-10 VDC, recirculation air, including sensor, Protection class IP 40	262 x 277 x 153	EC units electromechanical, 10 TIP, TOP or Ultra Unit Heaters, 10 Venkon Fan Coils, 2 KaCool D AF or KaCool W Fan Coils	196000030515

CONTINUED ▶



Accessories

Article	Article	Properties	Dimensions [mm]	Suitable for	Article no.
---------	---------	------------	--------------------	--------------	-------------

Thermostats

	Room thermostat	with thermal feedback, 230 V AC, Surface-mounted, Protection class IP 30	78 x 28 x 83	Unit Heaters, Galaxis Radiant Ceiling Panels	196000030055
	Industrial thermostat	with setpoint adjustment by tool, Protection class IP 54	113 x 71 x 158	Unit Heaters, ProtecTor Door Air Curtains, Galaxis Radiant Ceiling Panels	196000030058
	Industrial thermostat	with setpoint adjustment using a dial, Protection class IP 54	113 x 71 x 158	Unit Heaters, ProtecTor Door Air Curtains, Galaxis Radiant Ceiling Panels	196000030059
	Clock thermostat	with integral digital timer, with day/night/week programme, with night setback, Protection class IP 20	84 x 33 x 133	Unit Heaters, Galaxis Radiant Ceiling Panels	196000030056

Valves

	Thermoelectric shut-off valve	230 V AC, Connection 1" Not in conjunction with 2-stage three-phase switch art. no. 196000030049!	200 x 50 x 300	all unit heaters	196000030911
	Thermoelectric shut-off valve	24 V AC/DC, Connection 1"	200 x 50 x 300	Only to be used with KaControl!	196000030931
	Control shut-off valve	230 V AC, DN 20, Connection 1"	140 x 120 x 140	Model size 4 - 5, TOP or Ultra Unit Heaters, Flow volume (min./max.) 180 - 1300 l/h	196000030950
		230 V AC, DN 25, Connection 1"	140 x 120 x 140	Model size 4 - 6, TOP or Ultra Unit Heaters, Flow volume (min./max.) 300 - 2000 l/h	196000030951
		24 V AC/DC, DN 20, Connection 1"	140 x 120 x 140	Model size 4 - 5, TOP or Ultra Unit Heaters, Flow volume (min./max.) 180 - 1300 l/h	196000030980
		24 V AC/DC, DN 25, Connection 1"	140 x 120 x 140	Model size 4 - 6, TOP or Ultra Unit Heaters, Flow volume (min./max.) 300 - 2000 l/h	196000030981

CONTINUED ▶

Accessories

Article	Article	Properties	Dimensions	Suitable for	Article no.
			[mm]		

Repair switch

	Repair switch	EC, Enables individual units in a switching group to be decommissioned by voltage disconnection. The thermal contacts are bridged in advance, and subsequently opened on the motor side so that the other units in the group can continue to operate without interruption. Protection class IP 65, 25 A, supplied separately	82 x 127 x 82	all unit heaters, air curtains with EC-motors	196000030160
---	---------------	--	---------------	---	---------------------



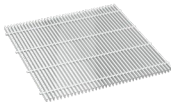

Filter

	Recirculating air filter element	for direct mounting on the unit inlet with recirculation air units, ISO Coarse 45% (G3) filter Cannot be used with under-ceiling units!	405 x 70 x 405	Model size 73 - 84	154000064050
			505 x 95 x 505	Model size 85	154000065050
			655 x 90 x 655	Model size 96	154000066050

Panel/grille

	Recirculating air grille	Grid dimensions 625 x 625 mm, powder coated Colour RAL 9016 traffic-white	620 x 18 x 620	Model size 73 - 96	154000060988
---	--------------------------	---	----------------	--------------------	---------------------

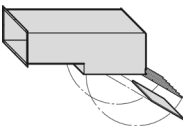
Components for installation in acoustic grid suspended ceilings

	Connection frame	square	600 x 160 x 600	Model size 85	198000065002
			700 x 160 x 700	Model size 96	198000066002
	Reducing angle 90°	extended, square to rectangular	610 x 350 x 1145	Model size 85	198000065104
			1220 x 375 x 700	Model size 96	198000066104
	Air inlet angled section, 90°	with air intake grille, mounting for filter insert, ISO Coarse 45% (G3) filter	700 x 429 x 1175	Model size 85 - 96	198000060105
	90° air intake bend with differential pressure switch	with intake grille, filter insert and differential pressure switch for filter monitoring, ISO Coarse 45% (G3) filter, factory-fitted	700 x 430 x 1165	Model size 85 - 96	198000060105D0
	Filter insert	complete with filter, ISO Coarse 45% (G3) filter	569 x 18 x 590	Model size 85 - 96	198000060126
	Replacement filter	for filter insert, ISO Coarse 45% (G3) filter, 1 set = 5 piece(s)	560 x 70 x 580	Model size 85 - 96	198000060127

Kampmanngroup.com/ultra

Subject to technical changes. 405/06.2021 UK

Kampmann GmbH & Co. KG
Friedrich-Ebert-Str. 128 - 130
49811 Lingen (Ems)
Germany

T +49 591 7108-660
F +49 591 7108-173
E export@kampmann.de
W Kampmanngroup.com

