

shape



Hudevad Plan



Technical datasheet

HUDEVAD
shape

Key benefits



Minimalistic Scandinavian design

A Hudevad trademark



2 mm steel front

High quality Swedish steel makes it durable and highly resistant to impact



The original flat front radiator

Water-filled flat front panel and convector tubes



Customisable shape and size

Single, double, curved, or angled
- you choose

Index

Description.....	4
Illustrations	5
Dimensions.....	5
Height and length	5
Tapping distances	6
Build-in dimensions	7
Position of rails.....	8
Built-in valves.....	8
UR Flex.....	10
Output	15
Options.....	17
Angled and curved	17
Horizon infill panel.....	18
Accessories	19
Brackets	19
Adjustable PR feet.....	19
FDC feet.....	21
Console feet	21
Tappings	22

Description

Hudevad Plan is the quintessence of clean, Scandinavian design. The radiator is of the highest quality, all the while having impressive output, poise and clarity. The simple design ensures that the Hudevad Plan radiator can fit in anywhere, and be an asset to any creative design endeavour an architect might have.

Material	Front plate: 2.00 mm steel to EN 10051 Rear plate: 1.25 mm steel to EN 10130 Plan convector tubes: 1.50 mm steel to DIN 239
Test pressure	10 bar
Max. operating pressure	7.7 bar in accordance with EN 442
Max. operating temperature	95°C
Surface treatment	Pretreatment: Degreasing and passivation Priming: Primed with water based paint in pale grey Surface treatment in accordance with DIN 55900 and EN 442
Length	Plan single and double: 400-3800 mm, in increments of 33.33 mm
Height	Plan single and double: 300, 400, 500, 600, 700 and 1000 mm
Depth	Plan single: 40, 60 and 80 mm Plan double: 126 and 166 mm
Tappings	1/2" standard, adapter for 3/4"
Installation	Wall or floor mounted Brackets are included Air vents and plugs are included
Optional extras	Console feet FH FDC feet, steel PR feet Adjustable brackets
Colour	Powder-coated white RAL 9010, gloss 70 Option: Painted in other standard RAL and BS colours

Illustration

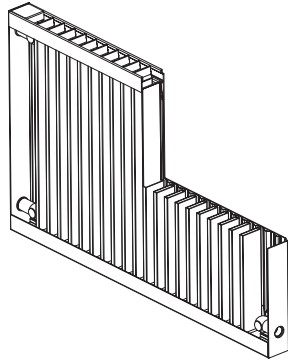

Plan single cutaway - rear view

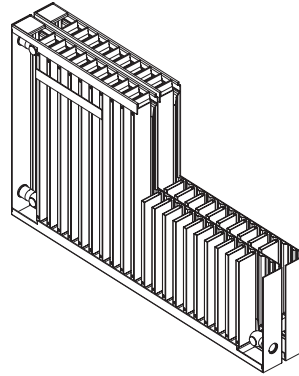

Plan double cutaway - rear view

Dimensions

Height and length

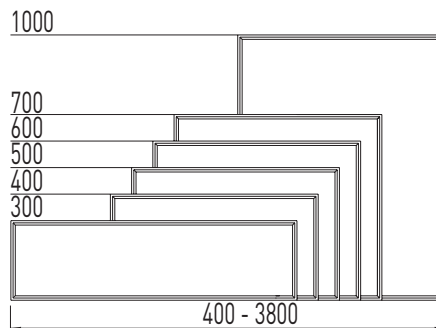

Plan single, profile view

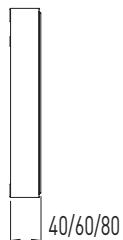

Plan double, profile view

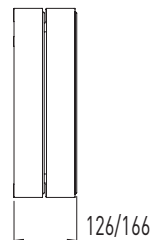

Weight max. 250 kg for Plan double

Tapping distances

Note: Always connect flow to the outermost tapping.

Where Plan radiator lengths exceed 1200 mm, and same-end tapplings are required (AB, CD, 2E or 2F), Plan double is manufactured with an internal flow diverter, and Plan single is factory-fitted with a rear return tube to ensure optimum water flow.

Forced water circulation does not change the standard tapping designations.

Side tapplings ABCD

Plan single and double, front view

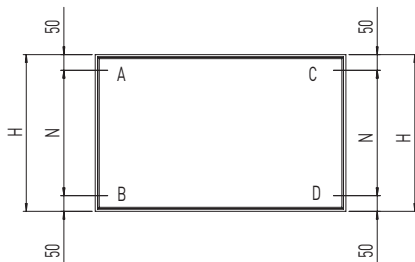

Plan single, profile view

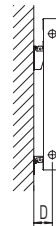

Plan double, profile view

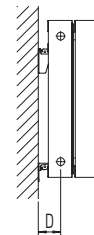

Bottom tapplings EF/FE

Plan single and double, front view

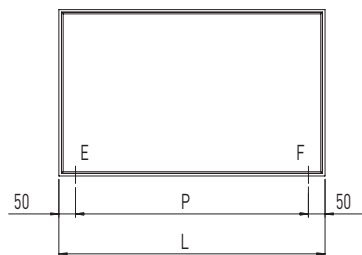

Plan single, profile view

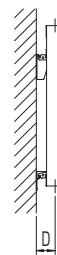

Plan double, profile view

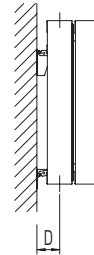

Centre distance P is calculated as:
Radiator length L-100 mm

Radiator height H, mm	Centre distance N, mm
300	200
400	300
500	400
600	500
700	600
1000	900

Depth, mm	D, mm
40	24/44
60	41/61
80	51/71
126	41/61
166	51/71

Bottom tapings EE/FF

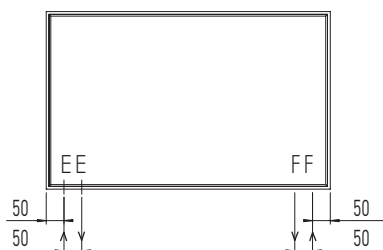

Plan single, profile view

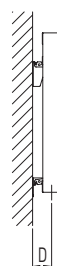

Plan double, profile view

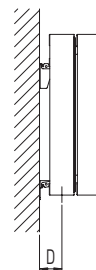

Build-in dimensions

Plan single, profile view

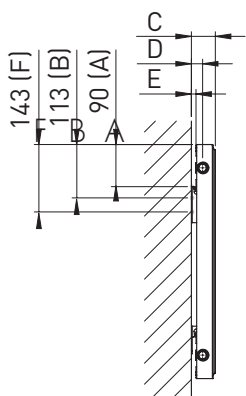

Plan double, profile view

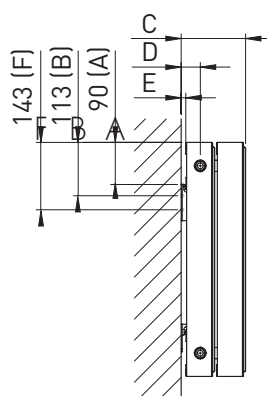

A = From upper edge of radiator to upper edge of bracket
 B = From upper edge of radiator to upper edge of screw hole
 F = From upper edge of radiator to lower edge of screw hole

Depth, mm	C, mm	D, mm	*E, mm
40	50/70	24/44	10/30
60	70/90	41/61	10/30
80	90/110	51/71	10/30
126	136/156	41/61	10/30
166	176/196	51/71	10/30

*Optional wall distance: 10 or 30 mm to rear of radiator
 UR-flex: Wall distance 30 mm

Position of rails

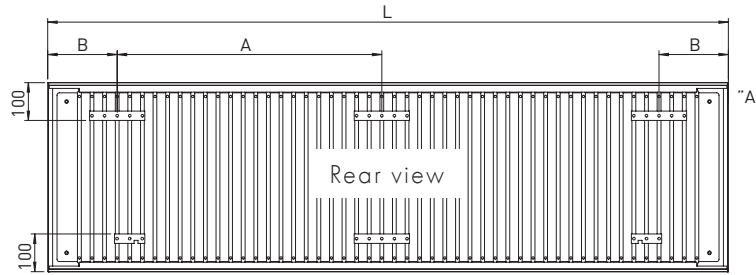

If the no. of brackets is 3 or more and the no. of sections is uneven, the rail in the middle is displaced 17 mm towards tapping "A".

Note: B = 250 mm at flow/return side on radiators with EE and FF tapplings.

Position of rails and no. of brackets

Radiator length L, mm	No. of sections	No. of brackets/spacers/rails	A, mm	B, mm
400-567	12-20	2/2/1	-	-
600-1667	21-50	2/2/2	L-366	183
1700-2467	51-74	3/3/3	(L-366)/2	183
2500-3800	75-114	4/4/4	(L-366)/3	183

Note: Also applies to all adjustable brackets.

Built-in valves

Application For use where a thermostatic valve is to be integrated within the radiator, where discreet pipework is required or for the ease of installation. Type 1 valve radiator has no water panel in the first 100 mm of the valve side. The thermostatic sensor of the valve is passed through a hole in the front of the radiator (type 1) or through the end of the radiator (type 3).

Tappings Type 1 and 3 valve radiators have underside 1/2" tappings. Tapping combinations EE/FF or EF/FE can be ordered. Air vent opposite the valve can be ordered. UR-flex tappings are available for concealed pipework.

Dimensions Minimum radiator length for built-in valve is 15 sections. In terms of heat output, integrated valves take up 2 sections.

Built-in valve Type 1 valves are supplied with spindle extenders for depths 126 and 166 mm. Type 3 valves are supplied with spindle extenders for all depths (40, 80, 126 and 166 mm).

Note: Spindle extender to be dismantled for presetting.

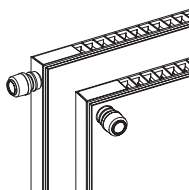

Plan single with built-in valve type 1 (front) and type 3 (side)

Built-in valve type 1

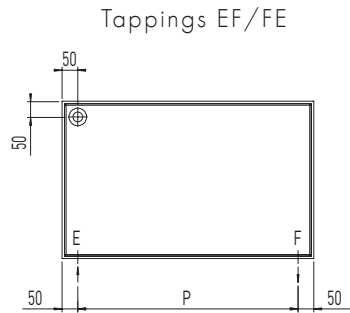
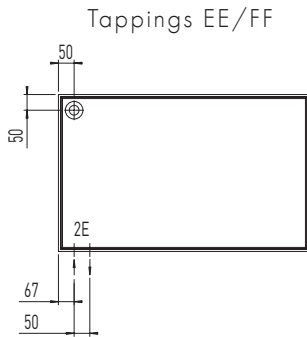

Built-in valve type 1, profile view

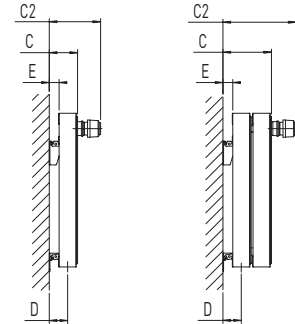

Centre distance P is calculated as:
Radiator length L-100 mm

Built-in valve type 3

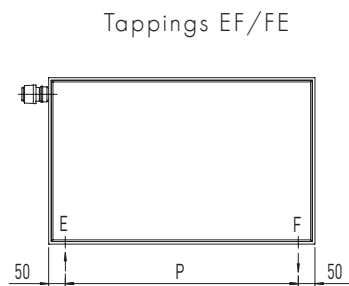
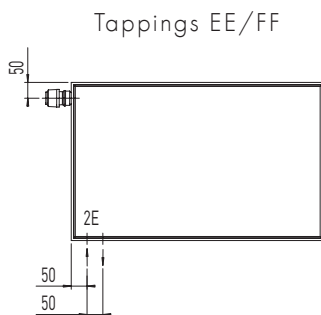

Built-in valve type 3, profile view

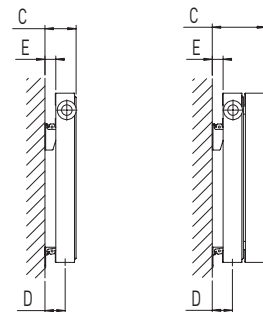

Centre distance P is calculated as:
Radiator length L-100 mm

Depth, mm	C, mm	C2, mm	D, mm	E, mm
40	70	146	44	30
60	90	166	61	30
80	110	186	71	30
126	156	232	61	30
166	196	272	71	30

UR-flex

Description	Plan with UR-flex embraces a simple, timeless design through a unique connection method that conceals all pipework. The radiators can be supplied for opposite end or same-end connections. Flexhoses made of high density armored medical silicone are included from factory. Extremely easy to clean due to the flat front, convector tubes and concealed pipework. The tappings and the UR-flex hoses are concealed behind the extended front plate. Only the air vent and the built-in valve are visible on the front.
Advice, etc.	UR-flex is not available with rear return tube. If same-end connections are required, the max. radiator length is 1200 mm. Radiators with lengths >1200 mm can only be supplied with diagonal tappings EF/FE.
Available for	Plan (depths 40-60-80-126-166)
Wall distance	30 mm
Installation	The UR-flex hoses (provided by Hudevad) are installed between the concealed radiator tappings and the wall outlets/ PEX sockets fitted by the SHAP installer. The radiator can then be mounted using the usual wall brackets. The UR-flex radiator types are also available without valves, to facilitate central valve location in an installations room, etc.

Plan with UR-flex, built-in valve format 1, profile

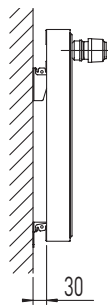

Plan with UR-flex, built-in valve format 3, profile

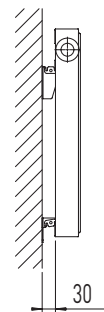

Plan with UR-flex, no valve, profile

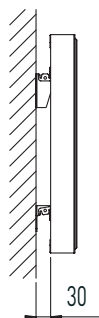

Plan with UR-flex, built-in valve format 4, profile

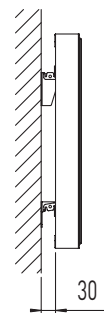

Built-in valve type 1

Model references and dimensional sketches for wall outlet/PEX socket location.

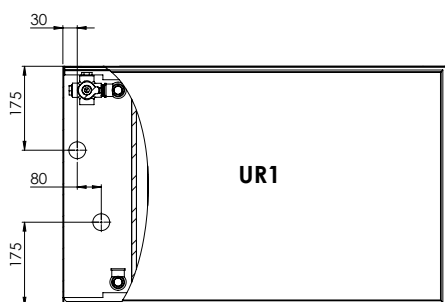

Built-in valve type 1, left, same end tapings, prepared for EE pipework.

If same end tapings are required, the max. radiator length is 1200 mm.

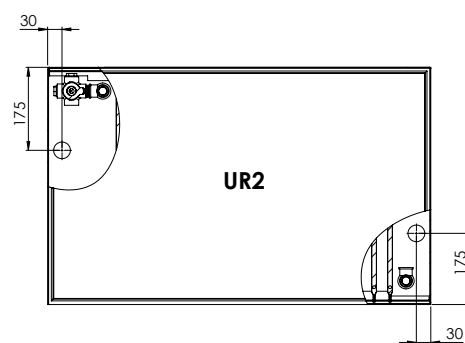

Built-in valve type 1, left, diagonal tapings, prepared for EF pipework.

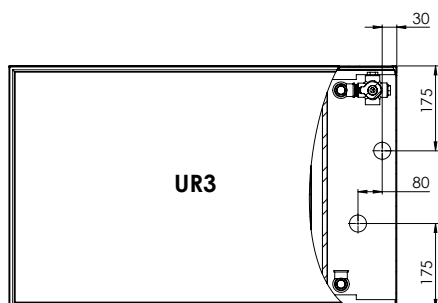

Built-in valve type 1, right, same-end tapings, prepared for FF pipework.

If same-end tapings are required, the max. radiator length is 1200 mm.

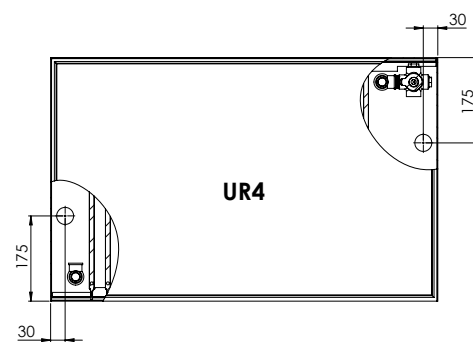

Built-in valve type 1, right, diagonal tapings, prepared for EF pipework.

Built-in valve type 3

Model references and dimensional sketches for wall outlet/PEX socket location.

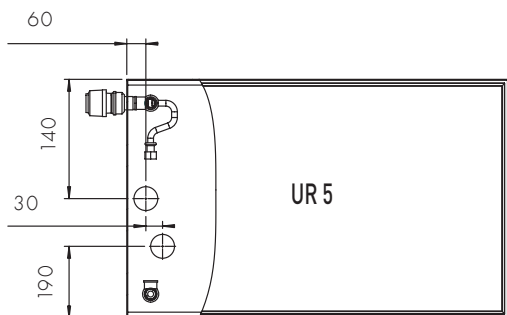

Built-in valve type 3, left, same-end tappings, prepared for EE pipework.

If same-end tappings are required, the max. radiator length is 1200 mm.

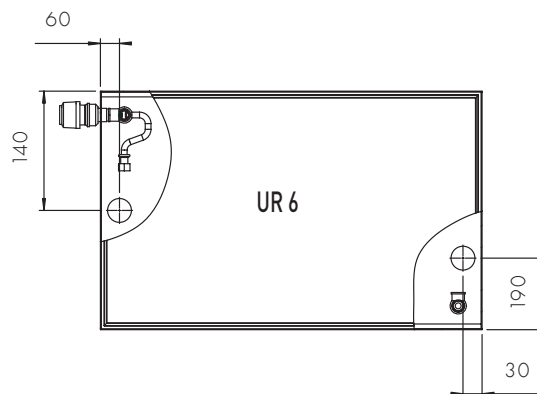

Built-in valve type 3, left, diagonal tappings, prepared for EF pipework.

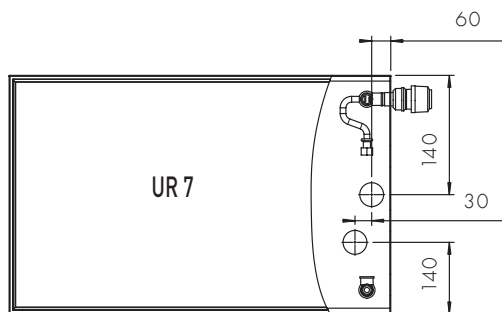

Built-in valve type 3, right, same-end tappings, prepared for FF pipework.

If same-end tappings are required, the max. radiator length is 1200 mm.

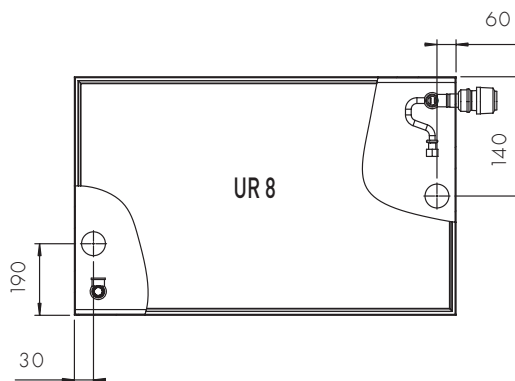

Built-in valve type 3, right, diagonal tappings, prepared for EF pipework.

No valve

Model references and dimensional sketches for wall outlet/PEX socket location.

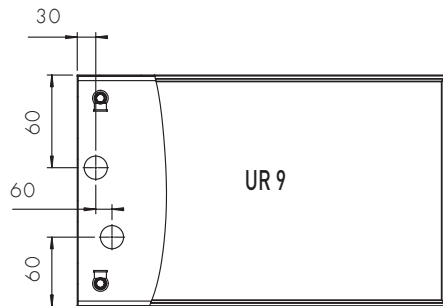

No valve, same-end tapings,
prepared for EE pipework.

If same-end tapings are required,
the max. radiator length is 1200 mm.

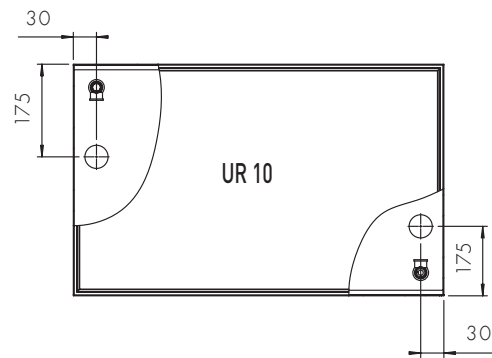

No valve, diagonal tapings,
prepared for EF pipework.

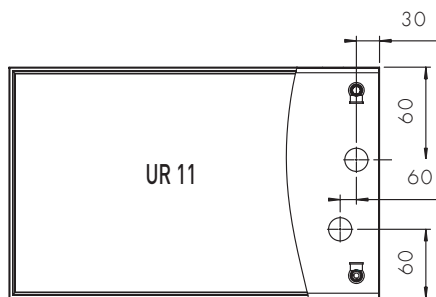

No valve, same-end tapings,
prepared for FF pipework.

If same-end tapings are required,
the max. radiator length is 1200 mm.

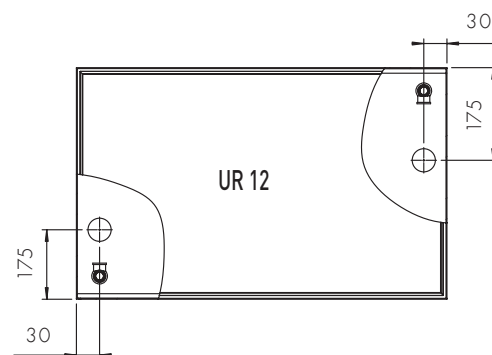

No valve, diagonal tapings,
prepared for EF pipework.

Built-in valve type 4

Model references and dimensional sketches for wall outlet/PEX socket location.

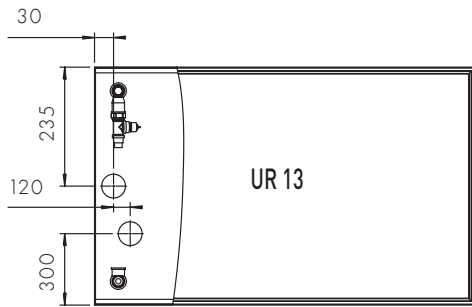

Built-in valve type 4, left, same-end tapplings, prepared for EE pipework.

If same-end tapplings are required, the max. radiator length is 1200 mm.

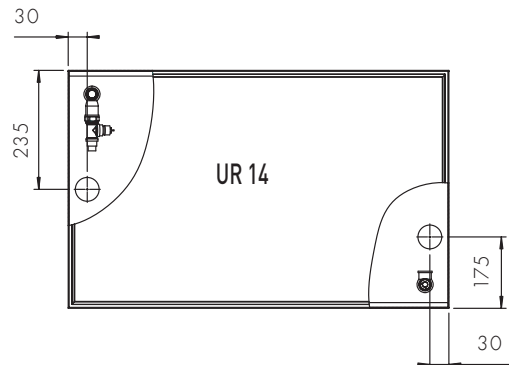

Built-in valve type 4, left, diagonal tapplings, prepared for EF pipework.

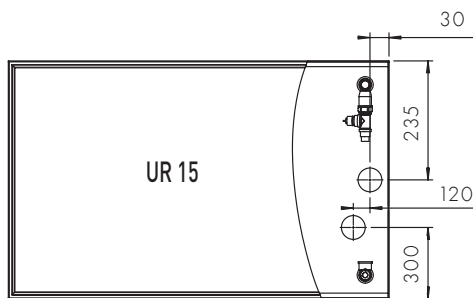

Built-in valve type 4, same-end tapplings, prepared for FF pipework.

If same-end tapplings are required, the max. radiator length is 1200 mm.

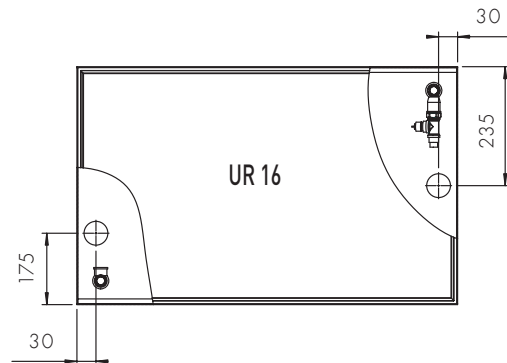

Built-in valve type 4, right, diagonal tapplings, prepared for EF pipework.

Output

Plan single

Depth, 40 mm	Output			Water content litres/ metre	Weight kg/ metre
	W/metre 75°/65°/20°	W/metre 55°/45°/20°	W/metre 90°/70°/20°		
Height, mm					
300	387	209	481	1.9	16.6
400	526	278	661	2.6	21.8
500	665	342	843	3.4	26.7
600	805	410	1024	4.1	31.5
700	944	476	1205	4.7	36.2
1000	1253	628	1602	7.0	51.5

Depth, 60 mm	Output			Water content litres/ metre	Weight kg/ metre
	W/metre 75°/65°/20°	W/metre 55°/45°/20°	W/metre 90°/70°/20°		
Height, mm					
300	466	253	580	2.7	20.5
400	633	333	797	3.7	27.0
500	802	408	1020	4.9	33.2
600	969	489	1237	5.9	39.3
700	1137	571	1455	7.0	45.3
1000	1510	746	1941	10.4	64.5

Depth, 80 mm	Output			Water content litres/ metre	Weight kg/ metre
	W/metre 75°/65°/20°	W/metre 55°/45°/20°	W/metre 90°/70°/20°		
Height, mm					
300	511	266	645	3.5	24.4
400	695	356	882	4.9	32.2
500	879	437	1129	6.4	39.7
600	1064	528	1366	7.8	47.1
700	1247	616	1604	9.3	54.4
1000	1655	818	2129	13.7	77.5

HUDEVAD
shape

Plan double

Depth, 126 mm	Output			Water content litres/ metre	Weight kg/ metre
	W/metre 75°/65°/20°	W/metre 55°/45°/20°	W/metre 90°/70°/20°		
Height, mm					
300	782	415	981	5.4	41.0
400	1064	559	1339	7.5	54.0
500	1345	721	1681	9.8	66.5
600	1628	842	2060	11.9	78.6
700	1909	953	2447	14.0	90.6
1000	2535	1265	3248	20.7	129.0

Depth, 166 mm	Output			Water content litres/ metre	Weight kg/ metre
	W/metre 75°/65°/20°	W/metre 55°/45°/20°	W/metre 90°/70°/20°		
Height, mm					
300	858	474	1060	7.0	48.8
400	1167	645	1442	9.8	64.4
500	1476	812	1827	12.8	79.5
600	1785	957	2230	15.7	94.1
700	2095	1101	2636	18.5	108.8
1000	2781	1417	3537	27.4	155.0

HUDEVAD
shape

Options

Angled and curved radiators

Description All Plan single radiators can be supplied angled or curved. Tapping designations etc. follow the same principles as for straight radiators.

Output calculation Same as Hudevad Plan, depth 40 mm (advisory calculation).

Installation Wall or floor mounted.

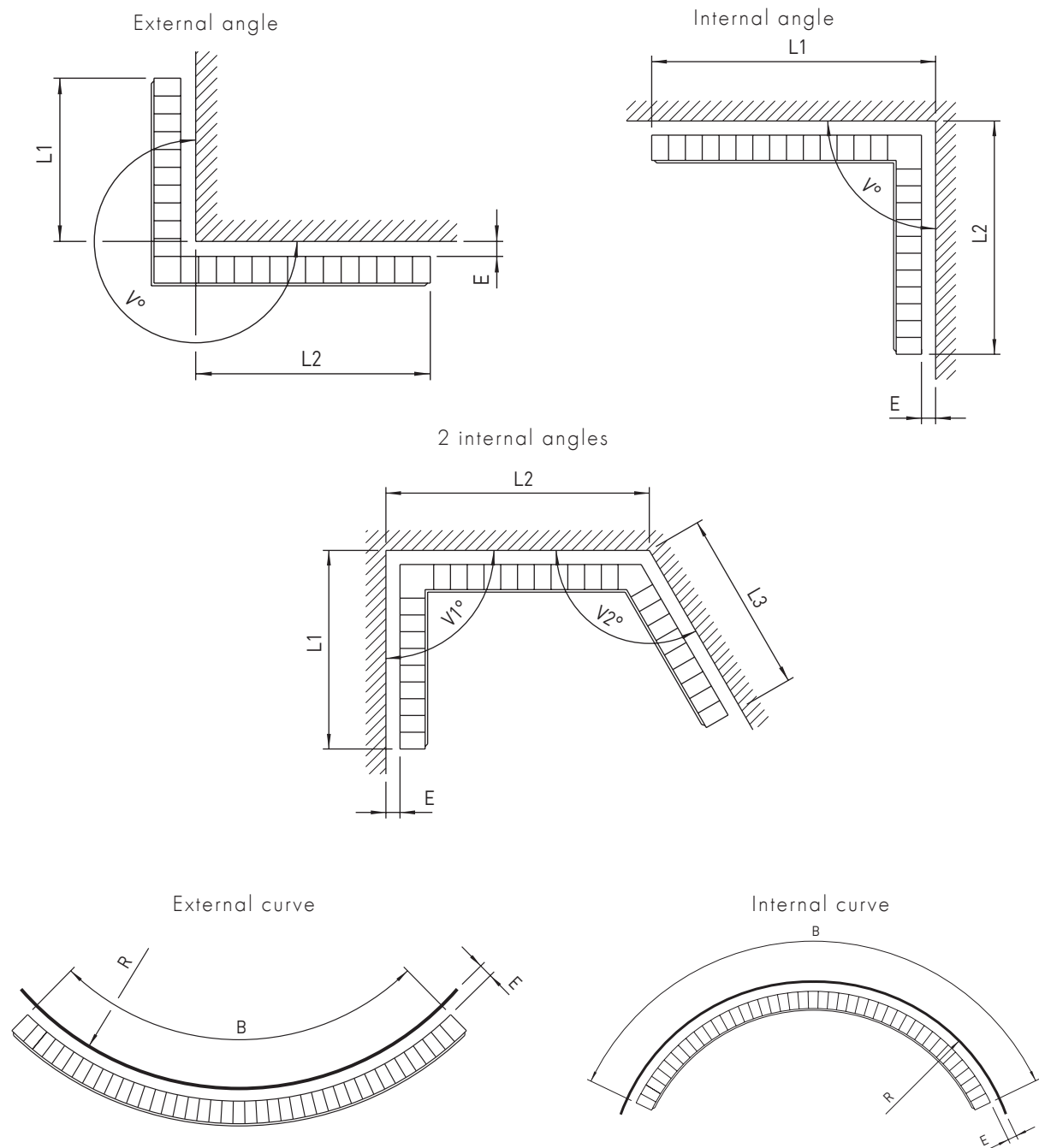

HUDEVAD
shape

Horizon infill and end panels

- Application** Used to connect several radiators installed in a line or as a dummy next to a radiator. Creates a continuous appearance where several radiators are connected. May also be used to cover pipework and electrical installations. Wall mounted. Can be dismantled for access to installations behind. Available as infill panels for installation between 2 radiators, as end panels for installation between radiator and wall, or to finish a string of radiators. Moreover, end panels can be ordered with closed ends if used to finish a string of free, wall mounted radiators.
- Design** Smooth rebated front plate with closed top. With folded edge to conceal gap between radiator and Horizon infill or end panel. Mounted on wall brackets. Brackets with screws and dowels are included.
- Lengths** Horizon infill panels: 200-2500 mm in increments of 1 mm
 Horizon end panels: 200-2500 mm in increments of 1 mm
- Height** Same as radiator.
- Depth** Same as radiator.
- Optional extras** Horizon end panels (can be ordered with closed ends to finish a string of free, wall mounted radiators), hole for valve, hole for socket, tamper-proof fixing, angled infill and end panels.

Horizon system, front view

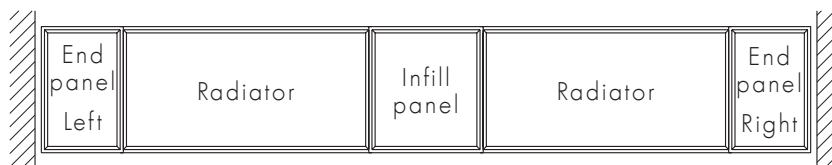

Horizon system, top view

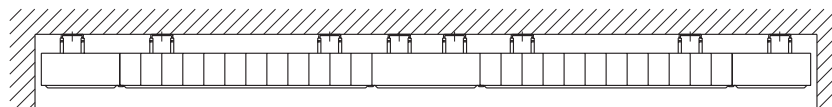

Wall mounting - Horizon infill and end panels
 Min. distance above radiator.

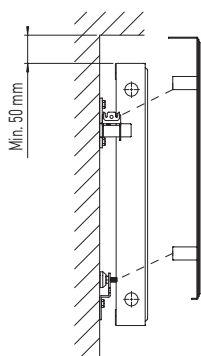

Wall mounting - Horizon infill and end panels with brackets and spacers, with tamper-proof fixing. Min. distance above radiator.

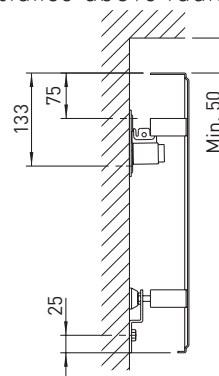

Horizon infill panel with tamper-proof fixing

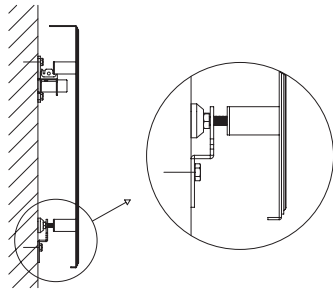

Closed ends, profile

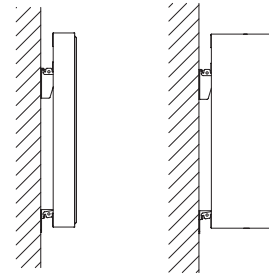

Accessories

Brackets

*Bracket BP10/30

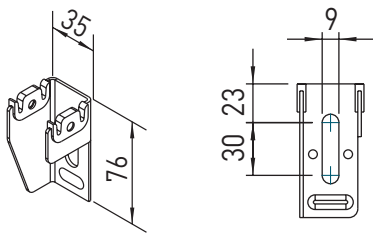

Adjustable spacer for bracket

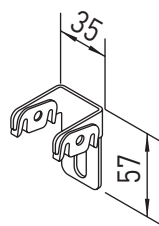

Adjustable brackets

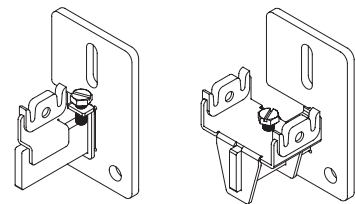

Adjustable console feet PR

PR feet, low - for Plan single and double

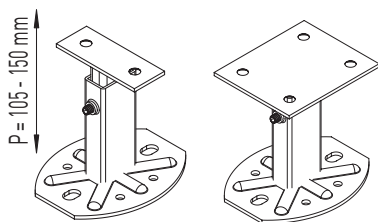

PR feet, high - for Plan single and double

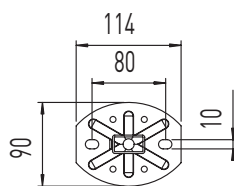
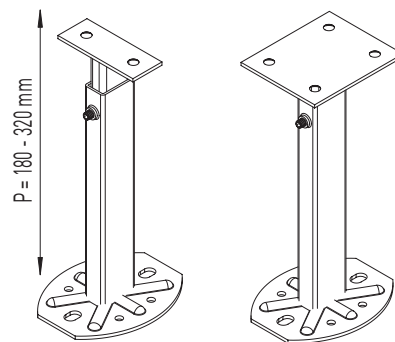

Hole dimensions: 20.5 x 35.4 mm

L x W: 124 x 103 mm

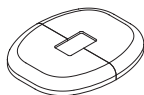

L x W: 70 x 50 mm

HUDEVAD
shape

PR feet positions and dimensions

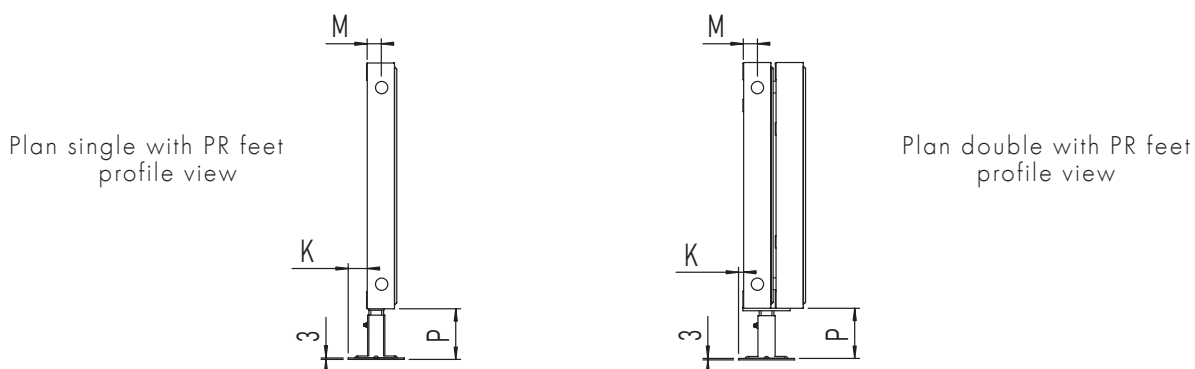

Distance K, M and P for foot plate

Depth, mm	K, mm	M, mm	P (low/high), mm
40	42	14	105-150 or 180-320
60	42	31	105-150 or 180-320
80	42	41	105-150 or 180-320
126	10	31	105-150 or 180-320
166	0	41	105-150 or 180-320

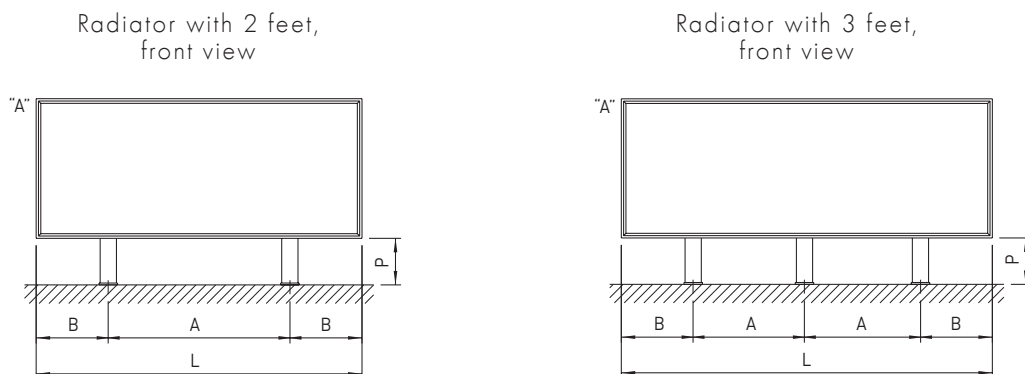

* If the no. of feet is 3 and the no. of sections is uneven, the foot in the middle is displaced 17 mm towards tapping "A".

Position and no. of feet, standard

L, mm	No. of sections	No. of feet	A, mm	B, mm
400-1800	12-54	2	L-266	133
1833-2500	55-75	3	L-266/2	133
2533-3800	76-114	4	L-266/3	133

Position and no. of feet, EE/FF

L, mm	No. of sections	No. of feet	A, mm	B, mm
400-1800	12-54	2	L-400	200
1833-2500	55-75	3	L-400/2	200
2533-3800	76-114	4	L-400/3	200

Note: Hudevad advises not to use feet for heights > 700 mm, measured from upper floor surface to upper edge of radiator, unless the radiator is additionally secured at the top.

FDC feet, steel

Height 100 mm (optional extra for depths 80, 126 and 166)

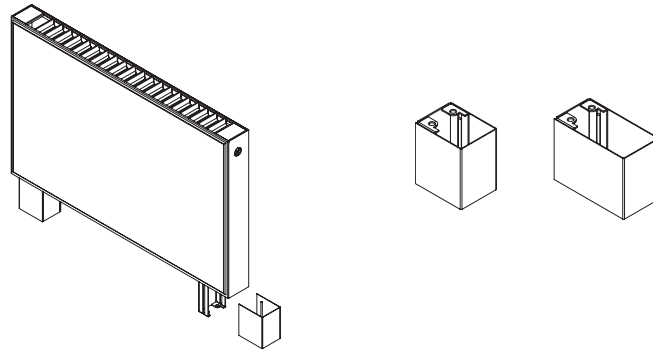

Console feet FH

Optional extra for all depts and heights

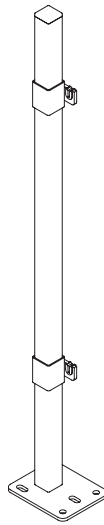

Tappings

