

Content

Page

2	Summary
Stations for solar energy	
3	“Regusol” Stations for solar energy
4	“Regusol” Stations for solar energy
5	“Regusol X” Stations with heat exchanger for solar energy
6	“Regusol X-Duo 15” and “Regusol X-Duo 25” Stations with heat exchanger for solar energy
7	“Regusol X-Uno 15” and “Regusol X-Uno 25” Stations with heat exchanger for solar energy
8	“Regusol X” System examples
9	Accessories and further products for solar energy
Stations for solid fuel boilers	
10	“Regumat RTA” Stations for solid fuel boilers
11	Further products for solid fuel boilers Safety device, mixing valves, distributors, controls
12	Further boiler accessories



Example: Construction of a solar installation in a one-family house

Stations for solar installations and for the connection of solid fuel boilers are becoming more and more important.

The reasons are not least the rising energy prices and the changing environmental consciousness of consumers.

These stations are not only installed in new buildings, but also existing systems are increasingly converted.

Nowadays, modern solar installations and the connection of solid fuel boilers can perfectly be coordinated with other components of the heating systems.

If nearly all partial systems of the installation are supplied by the same manufacturer, everything adds up and functions perfectly.

With their product ranges “Regusol” and “Regumat RTA”, Oventrop offers complete systems for the Building Services Industry.

The station “Regusol” consists of the transmission unit, the pump circuit as well as isolating and safety devices (safety valve, check valve, flow measuring device, fill and drain ball valve etc.).

For the connection of solar circuits to loading circuits via heat exchangers, Oventrop offers the system “Regusol X”.

The station “Regumat RTA” consists of a boiler connection system for the connection of the heating system/storage cylinder to the solid fuel boiler.

Oventrop products for solar systems and for the connection of solid fuel boilers are high quality products.

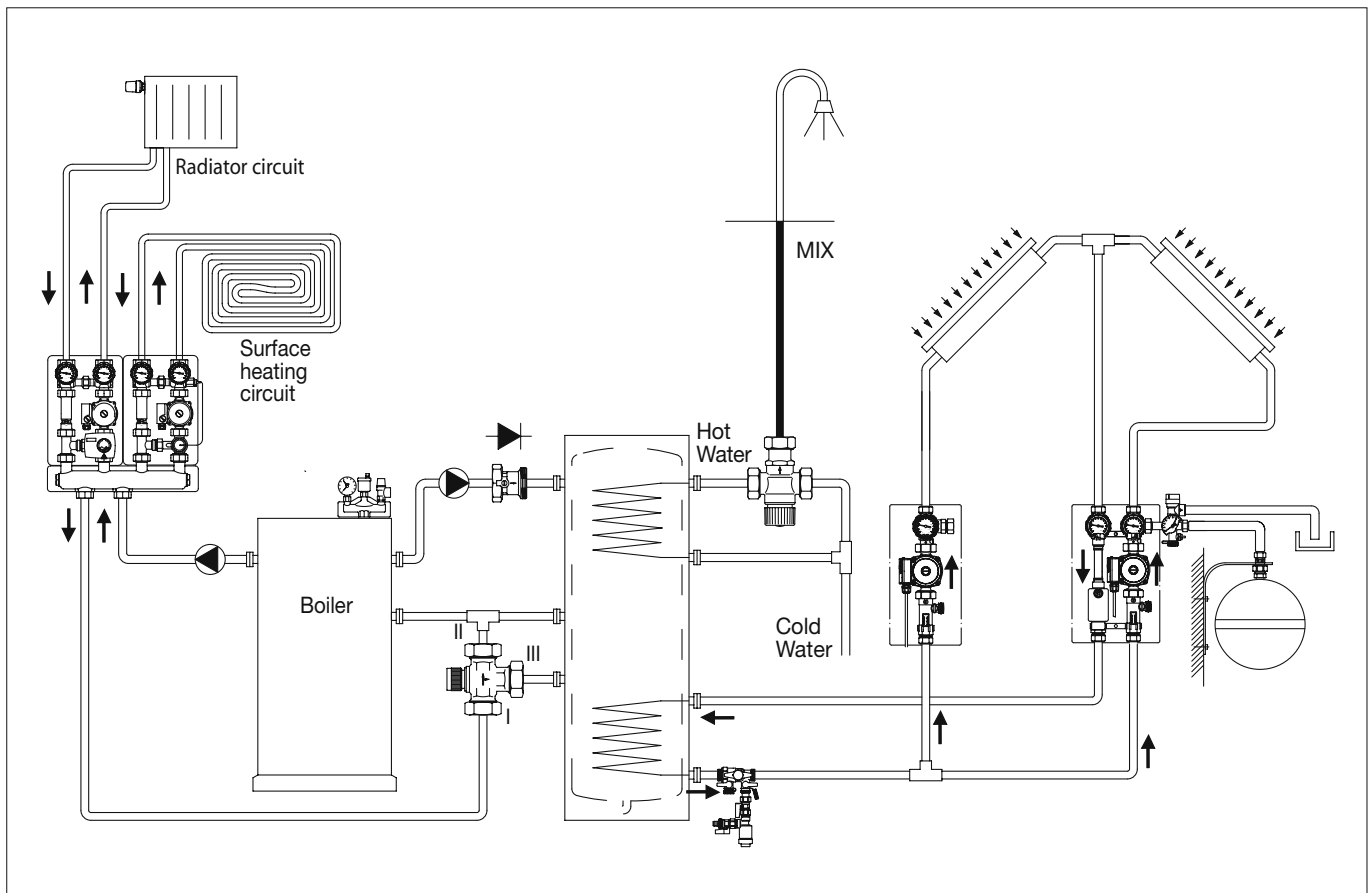

Example: Integration of a solar installation into a heating system

Due to the integration of all components into a pre-assembled, leak tested and heat insulated unit, installation is simplified considerably. The used materials as well as the specific order of the individual components are perfectly coordinated with the high demands on the solar system. A long-lasting safe and perfect function of the system is guaranteed.

The corresponding pump lengths of the units are 130 mm (standard model) or to 180 mm. Flow measuring and regulating devices for different control ranges are available. Transmission units are available with integrated deaerator. Possible airlocks arising in the system are gathered here and can manually be expelled into the atmosphere. This way, operational reliability can additionally be increased. Apart from the hydronic components, the units “Regusol E-130” and “Regusol EL-130” include a complete, pre-assembled, digital control for the solar system.

Advantages of the Oventrop station “Regusol”:

- high functional efficiency due to high quality material
- all components from one supplier
- complete systems available
- simple installation
- max. short-term starting temperature 160°C
- max. continuous working temperature in the supply 120°C
- with insulation



1



2



3



4



5



6



7



8

1 Transmission station “Regusol-130” with safety group (pump length 130 mm) for the connection to the solar circuit DN 25 using compression fittings “Regusol”. Complete, pre-assembled and leak tested station with safety group and facility to connect to an expansion tank.

2 Transmission station “Regusol L-130” Same construction as transmission station “Regusol-130” with additional deaerator for an effective deaeration of the heat transfer medium in the supply.

3 Pump circuit “Regusol-130” with safety group, same construction as the return of the transmission station “Regusol-130”. Check valve integrated in ball valve.

4 Transmission station “Regusol E-130” Same construction as transmission station “Regusol-130” with additional electronic digital control (Prozeda or Resol).

5 Transmission station “Regusol EL-130” Same construction as transmission station “Regusol L-130” with additional electronic digital control (Prozeda or Resol).

6 Transmission station “Regusol-180” with safety group (pump length 180 mm) for the connection to the solar circuit DN 25 using compression fittings “Regusol”. Complete, pre-assembled and leak tested station with safety group and facility to connect to an expansion tank.

7 Transmission station “Regusol L-180” Same construction as transmission station “Regusol-180” with additional deaerator for an effective deaeration of the heat transfer medium in the supply.

8 Pump circuit “Regusol-180” with safety group, same construction as the return of the transmission station “Regusol-180”. Check valve integrated in the ball valve.



1 Product assembly “Regusol X” with or without electronic control, with heat exchanger for a controlled transmission of the heat of the solar circuit (primary circuit) to a monovalent storage cylinder (secondary circuit); e.g. for existing storage cylinders without direct solar circuit connection.

Complete pre-assembled and leak tested unit.

A three-way valve is integrated in the supply of the secondary circuit. This also allows the conversion to a parallel running loading circuit for loading of the storage cylinder section by section and for thermal loading of another storage cylinder.

The heat exchanger, a soldered panel heat exchanger, complies with the demands of the European Pressure Equipment Directive (PED). Due to turbulent flow conditions, an excellent self-cleaning effect is produced and a contamination is avoided.

The solar circuit is protected against excess pressure by a safety group integrated in the heat exchanger system.

The effective heat transmission depends on:

- the achieved flow temperature and the flow rate of the primary circuit
- the flow temperature difference between the primary and secondary circuit
- the required flow temperature and the flow rate of the secondary circuit

2 System illustration

Integration of the station with heat exchanger for solar installations into a heating system with storage cylinder loading section by section.

1

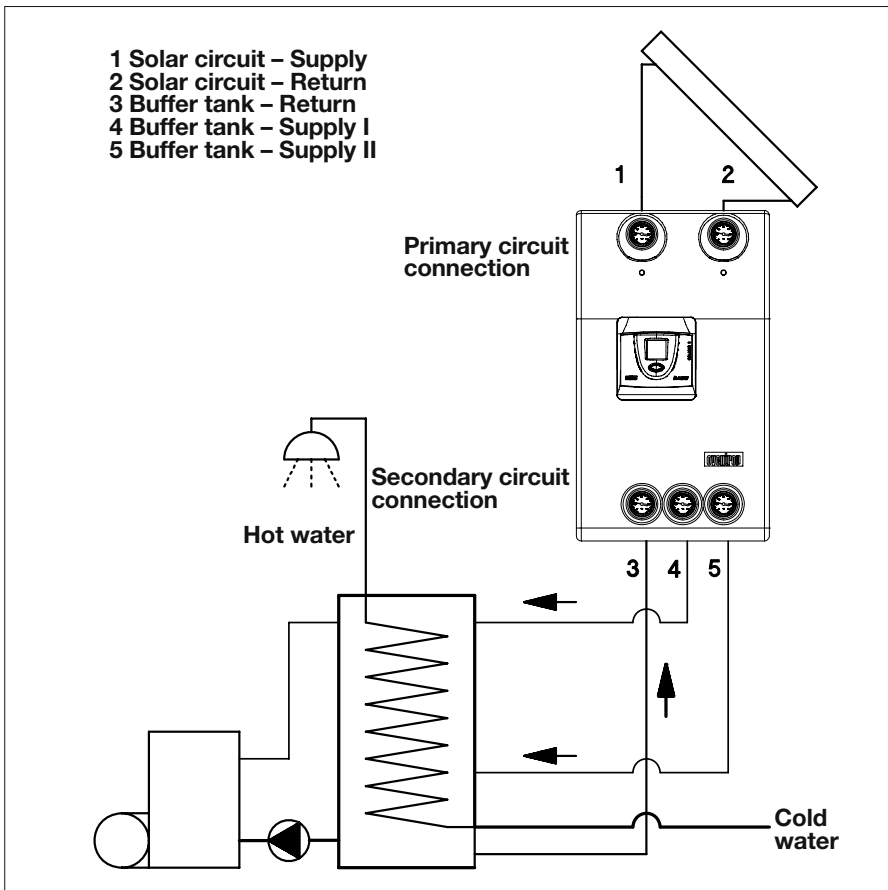

2



1

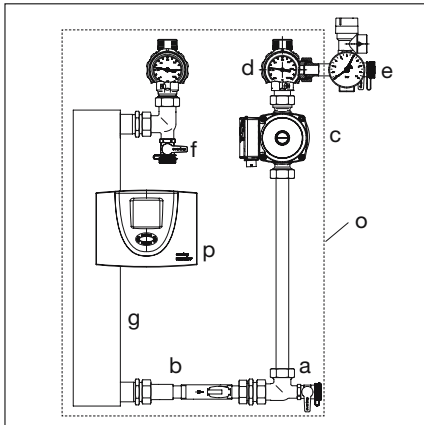

2

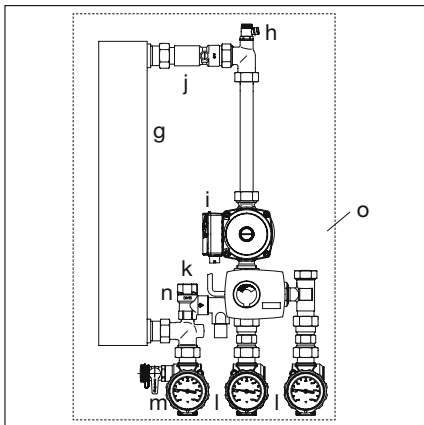

3

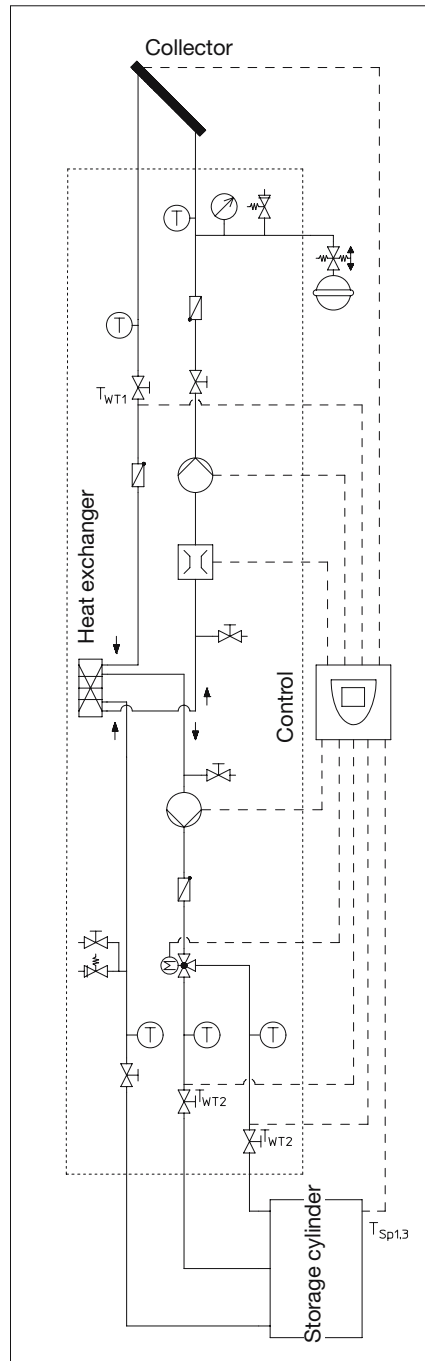

4

1 Station “Regusol X-Duo 25” with or without electronic control, with heat exchanger with three-way conversion valve for second loading circuit, completely pre-assembled on carrier board.

Performance class 15 KW
Number of heat exchanger plates 20

Design example:
Performance class 15 KW
for collector surface 30 m²

in solar circuit (primary circuit)

Velocity 6 l/min.

Pressure loss 76 mbar

in storage cylinder circuit (secondary circuit)

Velocity 5.4 l/min.

Pressure loss 40 mbar

or

Station “Regusol X-Duo 25” with or without electronic control, with heat exchanger, with three-way conversion valve for second loading circuit, completely pre-assembled on carrier board.

Performance class 25 KW
Number of heat exchanger plates 30

Design example:
Performance class 25 KW
for collector surface 50 m²

in solar circuit (primary circuit)

Velocity 10 l/min.

Pressure loss 94 mbar

in storage cylinder circuit (secondary circuit)

Velocity 9 l/min.

Pressure loss 79 mbar

2 System illustration

Arrangement of the solar circuit components (primary circuit) “Regusol X-Duo”:

- a Filling and flushing connection
- b Electronic flow transducer
- c Pump (solar circuit)
- d Ball valve with check valve, temperature sensor connection and thermometer inside the handle, with connection for safety group
- e Safety group with safety valve (6 bar), pressure gauge, fill and drain ball valve and connection for an expansion tank
- f Ball valve with check valve, temperature sensor connection and thermometer inside the handle with additional fill and drain valve in the elbow
- g Panel heat exchanger
- o Insulation with integrated control
- p Solar control with different programmable loading strategies
 - Target loading of upper section of the storage cylinder
 - Active loading section by section
 - Loading of complete storage cylinder

3 System illustration

Arrangement of the loading circuit components (secondary circuit) “Regusol X-Duo”:

- g Panel heat exchanger
- h Vent plug
- i Pump (loading circuit)
- j Check valve
- k Three-way conversion valve with actuator
- l Ball valve with temperature sensor connection and thermometer inside the handle
- m Ball valve with temperature sensor connection, thermometer inside the handle and fill and drain valve
- n Safety valve (3 bar)
- o Insulation

4 Hydronic circuit diagram with connection diagram for controller within “Regusol X-Duo”

5 Principal circuit diagram of the most important control functions

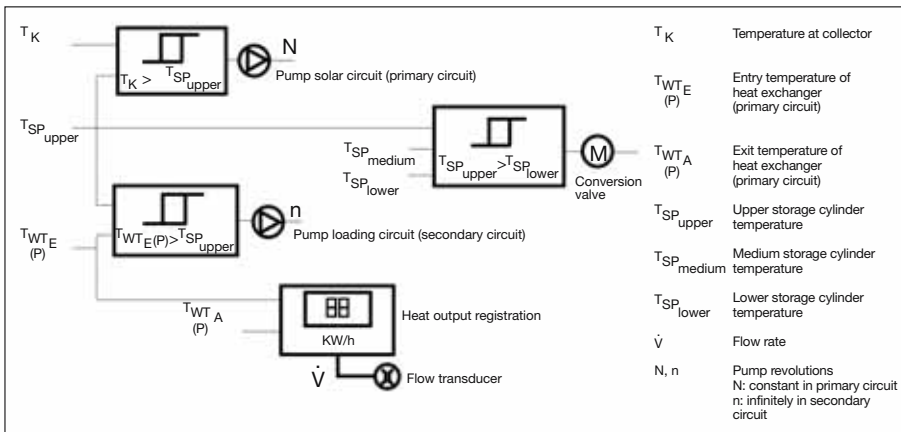

5

6



1

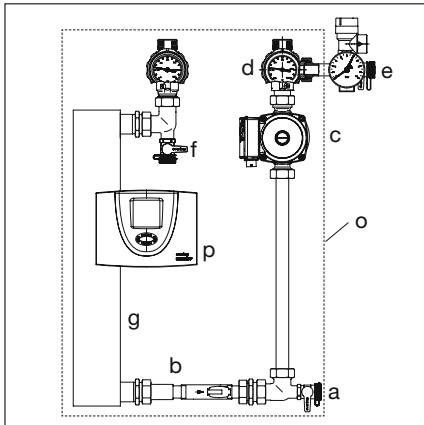

2

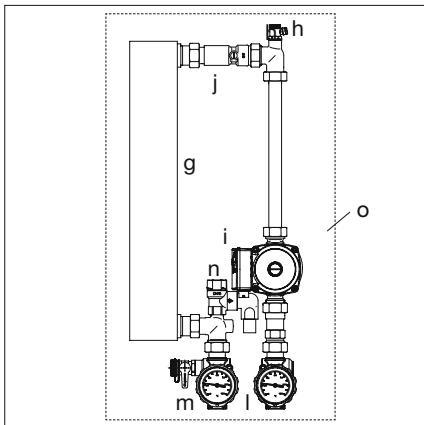

3

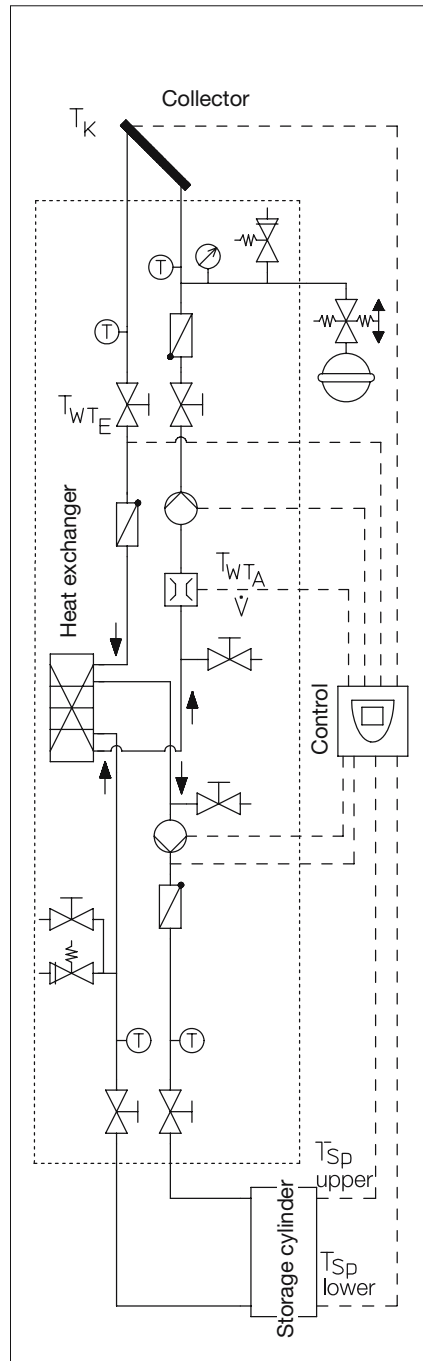

4

1 Station “Regusol X-Uno 15” with or without electronic control, with heat exchanger for transmission of the heat of the solar circuit (primary circuit) to a loading circuit (secondary circuit), completely pre-assembled on carrier board.

Performance class: 15 KW
Number of heat exchanger plates: 20

Design example:
Performance class 15 KW
for collector surface 30 m²
in solar circuit (primary circuit)

Velocity 6 l/min.
Pressure loss 76 mbar
in storage cylinder circuit (secondary circuit)
Velocity 5.4 l/min.
Pressure loss 40 mbar

or

Station “Regusol X-Uno 25” with or without electronic control, with heat exchanger for transmission of the heat of the solar circuit (primary circuit) to a loading circuit (secondary circuit), completely pre-assembled on carrier board.

Performance class 25 KW
Number of heat exchanger plates 30

Design example:
Performance class 25 KW
for collector surface 50 m²
in solar circuit (primary circuit)

Velocity 10 l/min.
Pressure loss 94 mbar
in storage cylinder circuit (secondary circuit)
Velocity 9 l/min.
Pressure loss 79 mbar

2 System illustration

Arrangement of the solar circuit components (primary circuit) “Regusol X-Uno”:

- a Filling and flushing connection
- b Electronic flow transducer
- c Pump (solar circuit)
- d Ball valve with check valve, temperature sensor connection and thermometer inside the handle, with connection for safety group
- e Safety group with safety valve (6 bar), pressure gauge, fill and drain ball valve and connection for an expansion tank
- f Ball valve with check valve, temperature sensor connection and thermometer inside the handle with additional fill and drain valve in the elbow
- g Panel heat exchanger
- o Insulation with integrated control
- p Solar control with different programmable loading strategies
 - Target loading of upper section of the storage cylinder
 - Active loading section by section
 - Loading of complete storage cylinder

3 System illustration

Arrangement of the loading circuit components (secondary circuit) “Regusol X-Uno”:

- g Panel heat exchanger
- h Vent plug
- i Pump (loading circuit)
- j Check valve
- l Ball valve with temperature sensor connection and thermometer inside the handle
- m Ball valve with temperature sensor connection, thermometer inside the handle and fill and drain valve
- n Safety valve (3 bar)
- o Insulation

4 Hydronic circuit diagram with connection diagram for controller within “Regusol X-Uno”

5 Principal circuit diagram of the most important control functions

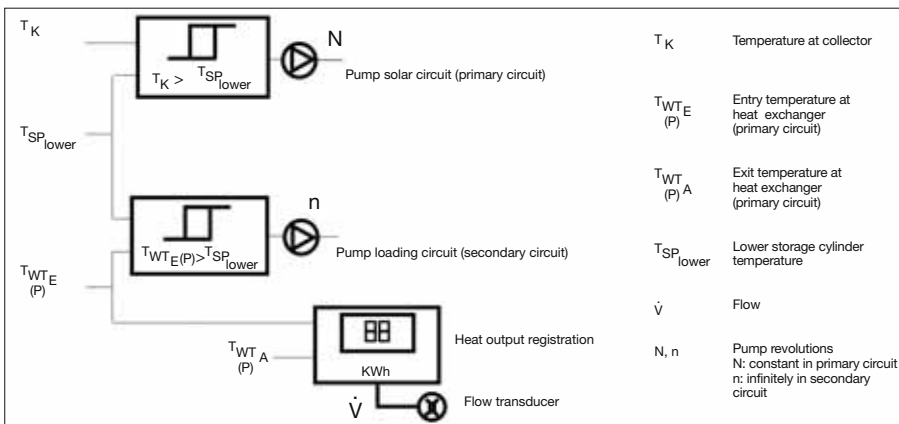

5

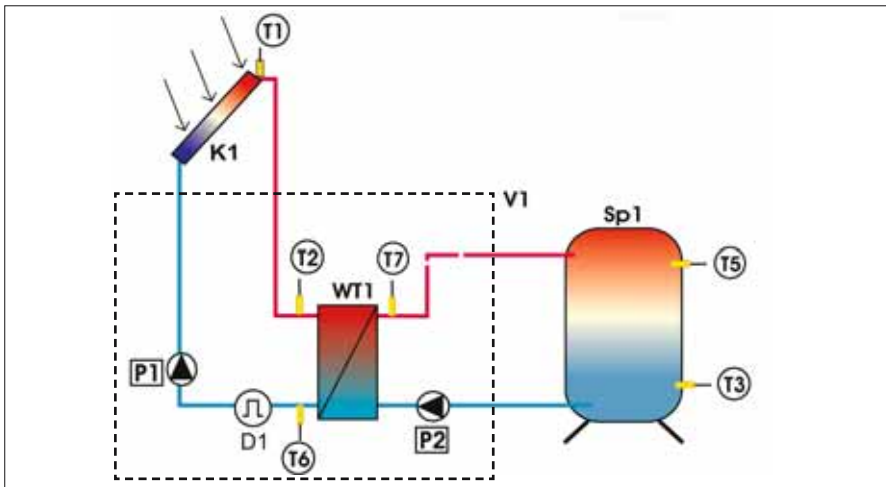

Storage cylinder connection for simple operation

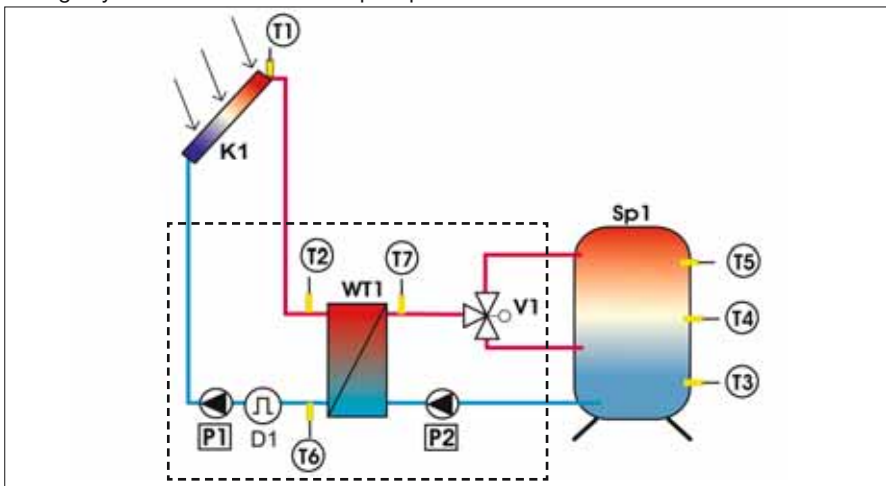

Storage cylinder connection for loading section by section

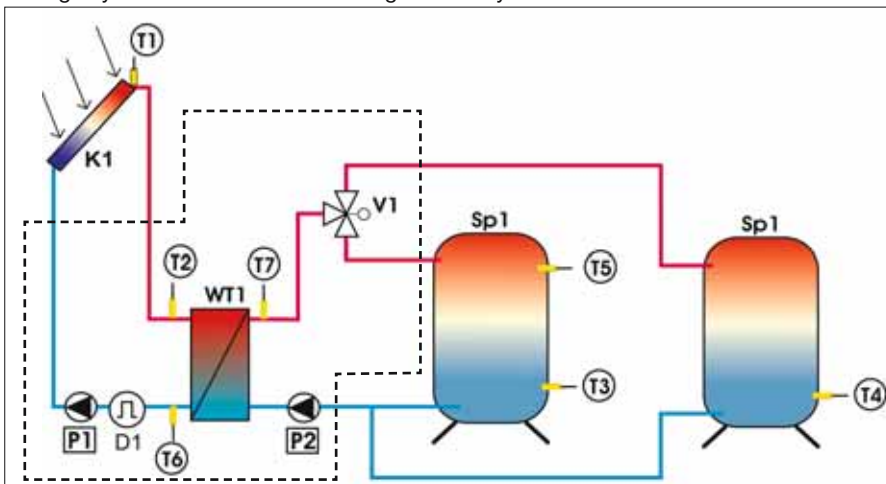

Storage cylinder connection for loading operation with 2 separate storage cylinders

”Regusol X-Uno 15”

Heat exchanger capacity 15 KW
for a collector surface of max. 30 m².

Primary circuit:

1 circuit for the connection of the collector fields.

Secondary circuit:

1 circuit for the connection of the storage cylinder for simple operation.

”Regusol X-Uno 25”

as ”Regusol X-Uno 15” but heat exchanger capacity 25 KW for a collector surface of max. 50 m².

”Regusol X-Duo 15”

Heat exchanger capacity 15 KW
for a collector surface of max. 30 m².

Primary circuit:

1 circuit for the connection of the collector fields.

Secondary circuit:

2 circuits for the connection of the storage cylinder for loading section by section.

”Regusol X-Duo 25”

as ”Regusol X-Duo 15” but heat exchanger capacity 25 KW for a collector surface of max. 50 m².

”Regusol X-Duo 15”

”Regusol X-Duo 25”

Primary circuit:

1 circuit for the connection of the collector fields.

Secondary circuit:

2 circuits but with loading operation for 2 separate storage cylinders.

”Regusol X-Uno“ (simple operation)	”Regusol X-Duo“ (storage cylinder with loading section by section)	”Regusol X-Duo“ (loading of 2 storage cylinders)
T5: Upper storage cylinder temperature T7: Heat exchanger exit point towards storage cylinder	T4: Medium storage cylinder temperature T5: Upper storage cylinder temperature T7: Heat exchanger exit point towards storage cylinder V1: Conversion valve for loading section by section	T4: Lower storage cylinder temp. (2. storage cylinder) T5: Upper storage cylinder temp. (1. storage cylinder) V1: Conversion valve for loading of 2 storage cylinders
T1: Collector temperature T2: Heat exchanger entry point towards collector T3: Lower storage cylinder temperature T6: Heat exchanger exit point towards collector	P1: Connection pump solar circuit P2: Connection pump loading circuit	D1: Connection flow-meter



1



2



3



4



5



6



7



8

1 Flow measuring and regulating device with isolation, e.g. for "Regusol-130", 2-15 l/min.

2 Venting circuit for replacement at existing transmission stations "Regusol-130" consisting of:
Ball valve with integrated check valve, thermometer and deaerator

3 Filling and flushing device "Regusol" Isolating ball valve with lateral connection for filling and flushing pipes to be installed at the lowest point of the solar circuit.

4 Filling pump "Regusol" Manual filling pump with hose connection and ball valves on suction and pressure side.

5 Temperature controller Connection thread M 30 x 1.5 with immersion sensor, is used for industrial installations, water heaters, air heaters, dishwashers, surface heating systems or similar. The control range can be limited or locked.

6 Connection set "Regusol" for the connection of a diaphragm expansion tank to the solar station "Regusol". Consisting of steel angled wall bracket, quick coupling for diaphragm expansion tank and a corrugated pipe.

7 Thermostatic mixing valve "Brawa-Mix" made of bronze, for domestic water installations PN 10 up to 100°C. Control range: 35-50°C

8 Brass ball valve "Optiflex" with male or female thread, self-sealing, with counternut, handle with stop, with hose connection (soft seal) and cap.



1

The station “Regumat RTA” allows the connection of the heating system/storage cylinder to the solid fuel boiler. The minimum return temperature to the solid fuel boiler amounts to of 55°C and thus lies above the dew point. It prevents the formation of pitch. During start-up, the boiler flow water is short circuited directly to the boiler return via the bypass. Having reached the return temperature of 55°C, the mixing valve opens to the heat emitters.

Advantages:

- pre-assembled station
- depending on the pump size, model “Regumat RTA-130” or “Regumat RTA-180”
- high quality materials
- insulation made of expanded polypropylene supplied with each “Regumat RTA”
- easy installation by use of tailpipe sets
- sensor integrated in the return

The station consists of one isolation set (ball valves with thermometers integrated in the handle for supply and return temperature display), check valve in the supply pipe to avoid gravity circulation, circulation pump (choice of Wilo or Grundfos pump with a length of 130 or 180 mm) in the return pipe, three-way mixing valve and temperature controller with immersion sensor, control range 40-70°C.

1 “Regumat RTA-130”

2 System illustration

3 “Regumat RTA-180”

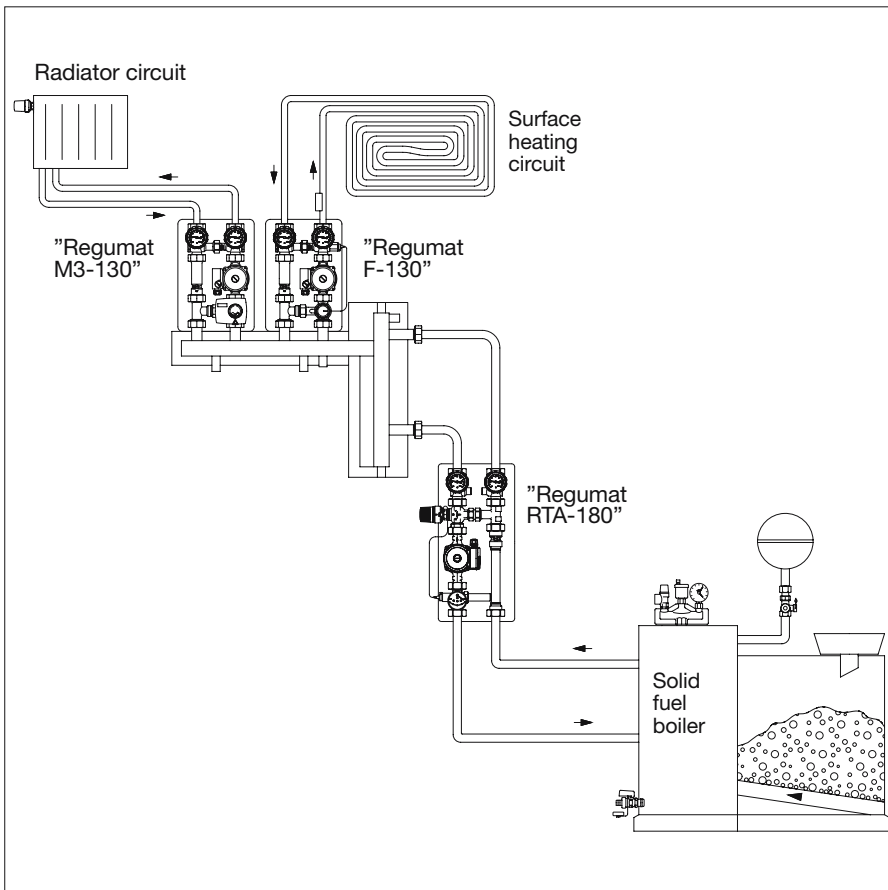

2



3



1 Distributor with insulation and wall brackets for the connection of 2 or 3 "Regumat" (up to 5 heating circuits).

2 Hydronic header for the hydronic decoupling of heating and boiler circuit, with insulation.
Hydronic UNIT 25
Combination of distributor and hydronic header.

3 Boiler safety device "MSM-Block" for closed heating systems according to DIN 4751 with a capacity up to 50 KW. The "MSM-Block" consists of: Brass body, pressure gauge, brass airvent with automatic shut-off, diaphragm safety valve 2.5 or 3 bar and insulation.
Models: Female threaded connection DN 25 1" and male threaded connection 1" flat sealing.

4 Mixing valve with actuator for flow temperature control in central heating systems with circulation pump. Manual or electromotive operation (il-lustr.).
Model: Three-way mixing valve, bronze four-way mixing valve DN 25 1" or DN 32 1 1/4".

5 Differential pressure relief device for subsequent conversion for "Regumat S/M3/M4" DN 25-130/180 and DN 32-180.

1



2



3



4



5



1



2



3



4



5



6



7



8

1 Pump ball valves "Optibal P" for a simplified installation of circulation pumps for hot water central heating systems. The pump ball valves are available with and without check valve.

2 Temperature controller with immersion or contact sensor and bronze three-way diverting or mixing valve PN 16. Especially suitable for return temperature increase of solid fuel and pellet boilers. Actuation also by use of electrothermal or electromotive actuators.

3 Valve with lead sealable cap "Expa-Con" with lead sealing device for the control, maintenance and possible replacement of diaphragm expansion tanks.

4 Airvents with automatic shut-off, made of brass; angle pattern model without automatic shut-off or precision airvent with automatic shut-off.

5 Bronze strainer with simple or double wire basket (for fine straining), wire basket made of stainless chromium steel.

6 Piston type spring assisted check valves and check valves. Piston type spring assisted check valves made of bronze, brass with FKM seal for horizontal and vertical installation. Bronze check valves with and without automatic deaeration, with female/male thread or with flanged connection.

7 Brass gauge cock for the use of gauges in heating systems. With gland nut and female thread, unplated or chrome plated.

8 Brass ball valve "Optiflex" with male or female thread, self-sealing, with counter nut, handle with stop, with hose connection (soft sealing) and cap.

Further information can be found in our catalogue, our technical data sheets as well as on our homepage www.oventrop.de, product ranges 6 and 7. Subject to technical modification without notice.

F. W. OVENTROP GmbH & Co. KG
Paul-Oventrop-Straße 1
D-59939 Olsberg
Germany
Telefon +49 (0) 29 62 82-0
Telefax +49 (0) 29 62 82-450
E-Mail mail@oventrop.de
Internet www.oventrop.de

OVENTROP UK LTD.
Unit E - The Loddon Centre
Wade Road
Basinkstoke, Hampshire RG 24, 8FL
Telephone (0 12 56) 33 04 41
Telefax (Sales) (0 12 56) 33 04 25
Telefax (General) (0 12 56) 47 09 70
E-Mail sales@oventrop.co.uk
Internet www.oventrop.co.uk