

HERZ-TS-E

Thermostatic valve with lower parts maximum flow
Standard models

Data Sheet

HERZ-TS-E

Edition 0504 (0504)

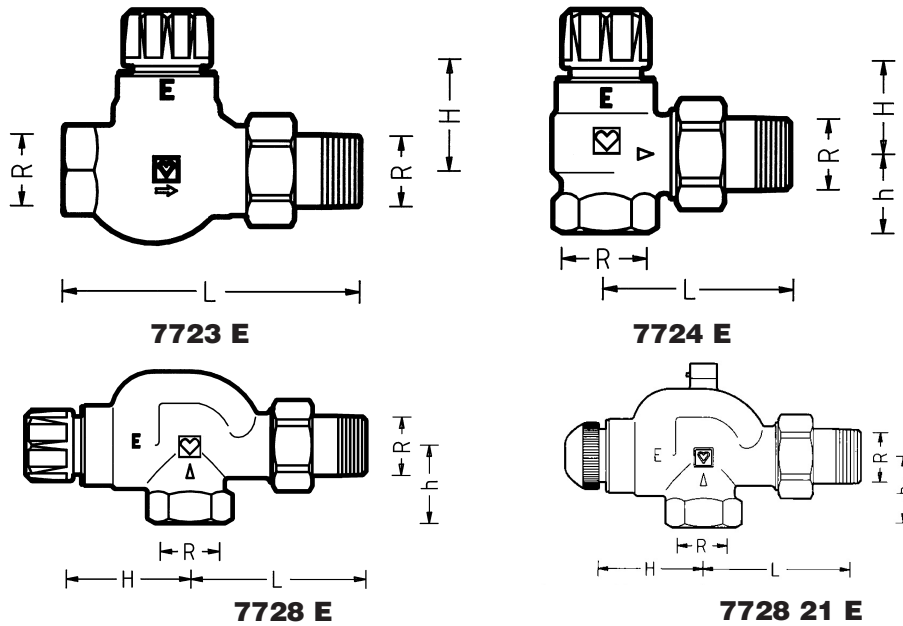

Dimensions in mm

Order No.	Description	DN	R	L	H	h
1 7723 11	Straight valve	15	1/2	95	43	—
1 7723 02		20	3/4	109	43	—
1 7723 03		25	1	126	43	—
1 7724 11	Angle valve	15	1/2	62	43	29
1 7724 02		20	3/4	66	35	29
1 7724 03		25	1	75	35	34
1 7728 11	Reverse angle valve	15	1/2	74	55	35
1 7728 02		20	3/4	80	55	35
1 7728 03		25	1	82	56	59
1 7728 21	with airbleeding	15	1/2	74	55	35

Standard models with threaded socket, nickel plated with white screw cap.

Models HERZ-TS-E

Universal models with special socket for threaded pipe and compression union

1 7723 01	1/2	Straight valve
1 7724 01	1/2	Angle valve
1 7728 01	1/2	Reverse angle valve
1 7758 01	1/2	3-Axis Valve "AB", valve to the left of radiator
1 7759 01	1/2	3-Axis Valve "CD", valve to the right of radiator

A separate standard sheet is available for these values.

**Other Models
HERZ-TS-90-E**

Max. operating temperature 120 °C
Max. operating pressure 10 bar
Max. permissible differential pressure in operation 0,2 bar (with mechanical shutoff up to 4 bar)

Hot water quality conforming to ÖNORM H 5195 and/or VDI guideline 2035.

Operating Data

One or two pipe water heating systems.

Field of Application

R 1/2, R 3/4: Iron pipe connection 6210, cone seal, assembled.
It is recommended to use HERZ-assembly key 6680.

R 1 Iron pipe connection 6209, cone seal, assembled.

Radiator Connections

We reserve the right to make modifications necessitated by technological progress.

HERZ Armaturen

Richard-Strauss-Straße 22 • A-1230 Wien
e-mail: office@herz-armaturen.com • www.herz-armaturen.com



HERZ-Standard diagram

HERZ-TS-E

Order number 7723 E, 7724 E, 7728 E

Dim. R = 1/2, 3/4, 1

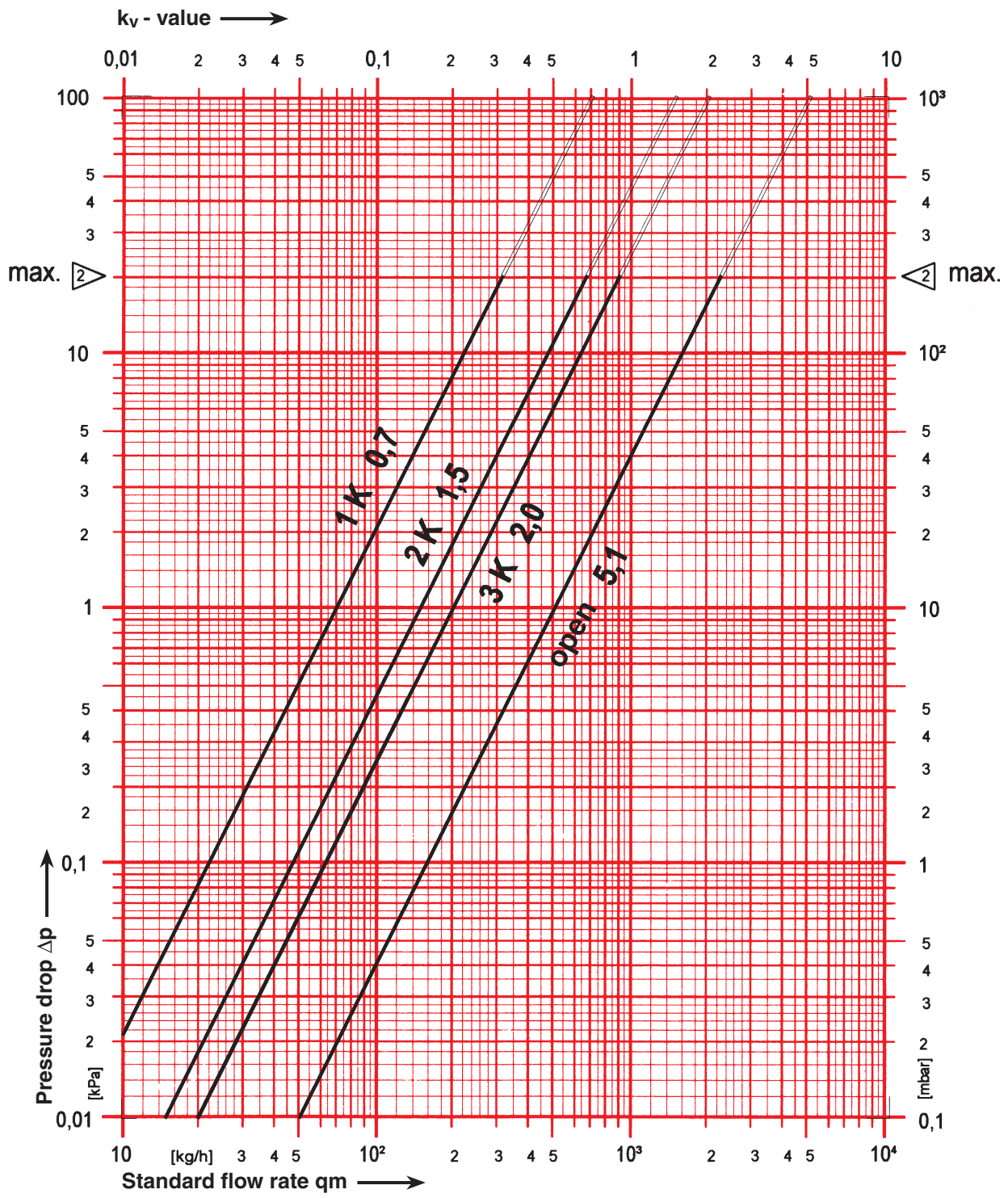

We reserve the right to make modifications.

6210	1/2	Iron pipe connection, lengths 26 or 35 mm.
6211	1/2	Reducing connection, 1/2 x 3/8.
6218	1/2-3/4	Long threaded bush, without nut, can be shortened to compensate for differences in structural dimensions, lengths 1/2 x 39, 42 and 76 mm; 3/4 x 70 mm.
6218	1/2	Threaded bush, without nut, lengths 36,48 and 76 mm.
6235	1/2-3/4	Soldering connection, 1/2 x 12, 15 and 18 mm; 3/4 x 18 mm.
6249	1/2-3/4	Iron pipe connection elbow, without nut, with cone seal.
6274	G 3/4	Compression union for copper and thin-walled steel pipes, for external pipe diameters 8,10,12,14,15,16 and 18 mm.
6275	G 3/4	Compression union with soft seal for copper and thin-walled steel pipes, particularly suitable for hard special steel pipes and pipes with hard galvanised surfaces. For external pipe diameters 12,14 and 15 mm.
6097, 6098	G 3/4	Compression union for PE-X-, PB and plastic composite pipes.

To be used at the socket side of the valve:

6219	1/2-3/4	Reduction socket, brass version, for pipe-valve connection, female thread (pipe) x male thread (valve), 1 x 1/2, 1 1/4 x 1/2, 1 x 3/4, 1 1/4 x 3/4.
6066, 6067	M 22 x 1,5	Plastic pipe connection for PE-X-, PB and plastic composite pipes, to be used with adapter 1 6272 01 (R 1/2 x M 22 x 1.5).
6097, 6098	G 3/4	Plastic pipe connection for PE-X-, PB and plastic composite pipes, to be used with adapter 1 6266 01 (R 1/2 x G3/4).

For pipe dimensions of plastic pipe connections please refer to Herz-catalogue.

Further Connecting Options

Please refer to the HERZ-catalogue for order numbers

An O-ring is used as a spindle seal. It is located in a brass chamber which can be changed during operation. The O-ring keeps maintenance requirements at a minimum and permits smooth valve operation over a long period of time.

Changing the O-ring

1. Remove the HERZ-thermostatic head and/or HERZ-TS hand wheel.
2. Then, unscrew the O-ring chamber including the O-ring and replace it with a new one. When doing this, use a wrench to hold the upper part. During dismantling, the valve is completely open and therefore sealed tight towards upstream. However, a few drops of water may leak out.
3. For re-assembly follow to the above steps in reverse sequence. When installing the HERZ-TS hand wheel, turn to make sure that the valve closes.

Order Number for O-ring set: 1 **6890** 00

Spindle Seal



HERZ-TS-90-O-Ring Chamber

The screw cap is for operating during the installation phase (pipe flushing). The thermostatic valve is formed by removing the screw cap and screwing in the HERZ-thermostatic head without draining the heating system.

Adjustment of nominal lift by means of screw cap:

On the knurled part of the circumference of the screw cap there are two setting marks (webs) in alignment with the "+" and "-" marks.

1. Close the valve by turning the screw cap clockwise.
2. Mark the position corresponding to the setting mark "+".
3. Turn the screw cap anti-clockwise until the setting mark "-" is at the position marked under item 2.

HERZ-Thermostatic Valve

Normal Lift

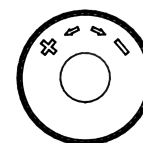

The lower part of the thermostatic valve is incorporated into the radiator intake with the flow in the direction of the arrow (arrow on the valve body). If possible, the HERZ-thermostatic head should be in a horizontal position in order to permit optimum room temperature control with minimum interference.

Installation

Under no circumstances should the HERZ-thermostatic head be exposed to direct sunlight or to the effects of equipment emitting relevant quantities of heat, e.g. TV sets. If the radiator is covered by curtains this will lead to the formation of a heat accumulation zone in which the thermostat cannot sense the room temperature properly and consequently cannot control it. In such cases, use the HERZ-thermostat with remote sensor or the HERZ-thermostat with remote adjustment.

For detailed information on the HERZ-thermostats consult the individual standard sheets.

Important for Installation

After the end of the heating period open thermostats or handwheels completely by turning anticlockwise, this prevents dirt particles accumulating at the valve seat.

Summer Setting

In case the lower part of a HERZ-thermostatic valve is not equipped with a HERZ-thermostatic head the HERZ-TS hand wheel will replace the screw cap.

For assembly follow the enclosed instructions.

HERZ-TS- Handwheel



- 1 **6680** 00 HERZ-assembly key for connections
- 1 **6807** 90 HERZ-TS-90 assembly key
- 1 **9102** 80 HERZ-TS-90 handwheel, Series 9000 "Design"

Accessoires

Handwheels

- 1 **6379** 03 HERZ-TS-E Thermostat upperpart
- 1 **6890** 00 HERZ-TS-90 O-Ring-set

Spare parts

All details contained in this brochure correspond to that available at the time of printing and are for information only. We reserve the right to make changes resulting from HERZ's ongoing development policy. The illustrations are understood to be indicative and may therefore vary visually from the actual products. Any differences in colour are due to the printing technology used. Products may also vary according to the country. We reserve the right to make changes to technical specifications and functions. For questions please contact your nearest HERZ office.